

FOR CHIP SEAL, THIN ASPHALT & DEEP ASPHALT

1. UNSEALED ROADS & SHOULDERS. REINSTATEMENT TO BE 150MM DEPTH OF 40MM BASCOURSE TOPPED OFF WITH 50MM DEPTH OF 20MM BASCOURSE.
2. FOR FINISHED SEAL LEVEL TOLERANCES SEE X-6(B) (PG 92).
3. *DEPTH TO MATCH EXISTING BITUMINOUS LAYER DEPTH, WHERE DEPTH IS GREATER THAN 50MM.

NELSON CITY COUNCIL	TRENCH REINSTATEMENT IN CARRIAGEWAY	
	ASSET MANAGEMENT DIVISION APPROVED  MANAGER INFRASTRUCTURAL ASSETS	PLAN No. 21/700 SHEET 1

Jan. 2003
DATE

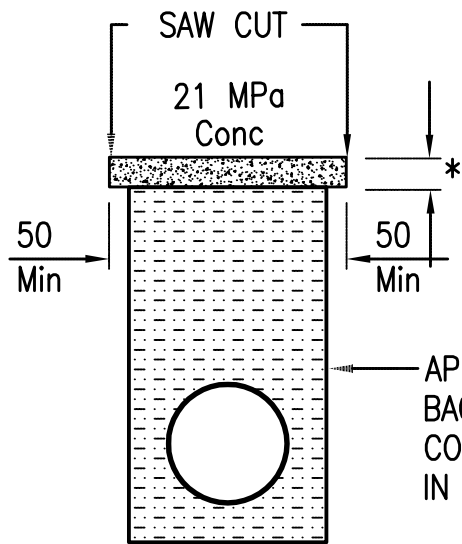

* 75mm FOR FOOTPATH. 100mm FOR RESIDENTIAL CROSSING WITH 665 MESH (or 150mm UNREINFORCED). 200mm FOR COMMERCIAL CROSSING WITH 665 MECH. FOR INDUSTRIAL CROSSING PAVEMENT TO SPECIFIC DESIGN (TO MATCH EXISTING).

CONCRETE

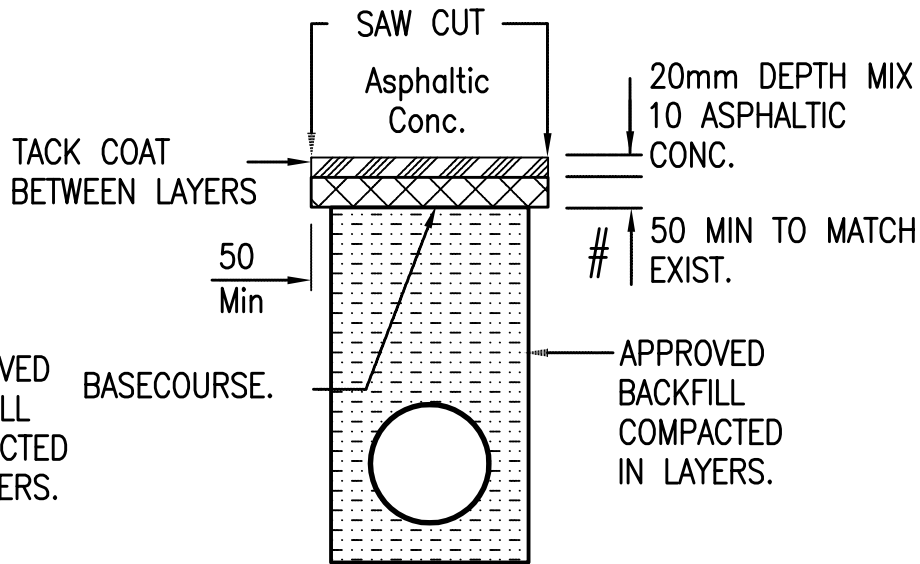

FOOTPATH PAVEMENT DEPTH MAY BE REQUIRED TO BE INCREASED WHERE BACKFILL MATERIAL IS OF LESSER QUALITY THAN SURROUNDING SUBGRADE MATERIAL.

**THIN ASPHALTIC
(FOR CHIP SEAL FOOTPATHS ALSO)**

FOR VEHICLE CROSSINGS DETAILS REFER TO 21/304 SHEETS 1 AND 2

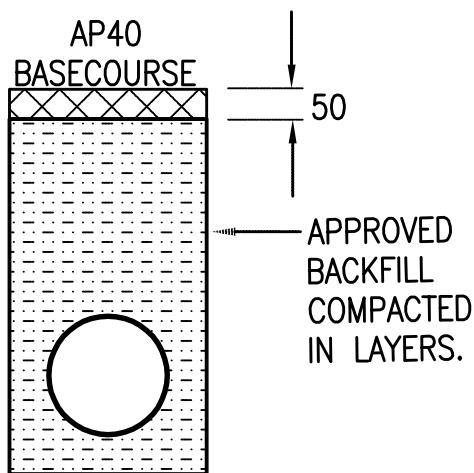

GRAVEL

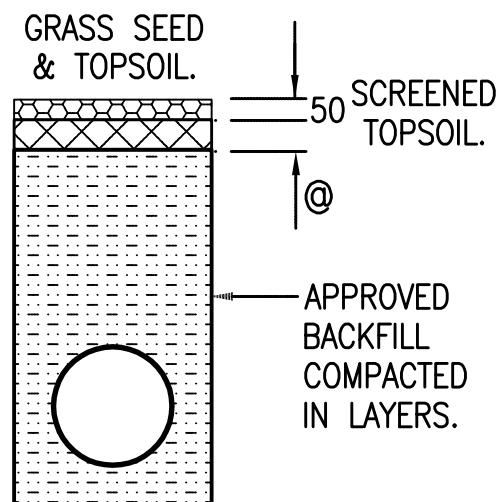

@ UNSCREENED TOPSOIL (50mm FOR CLAY FILLS, 100MM FOR GRAVEL OR SAND FILLS). **GRASS**

**NELSON
CITY
COUNCIL**

**TRENCH REINSTATEMENT IN
FOOTPATH**

ASSET MANAGEMENT DIVISION

APPROVED

MANAGER INFRASTRUCTURAL ASSETS

Jan. 2003

DATE

PLAN No.

21/700

SHEET 2

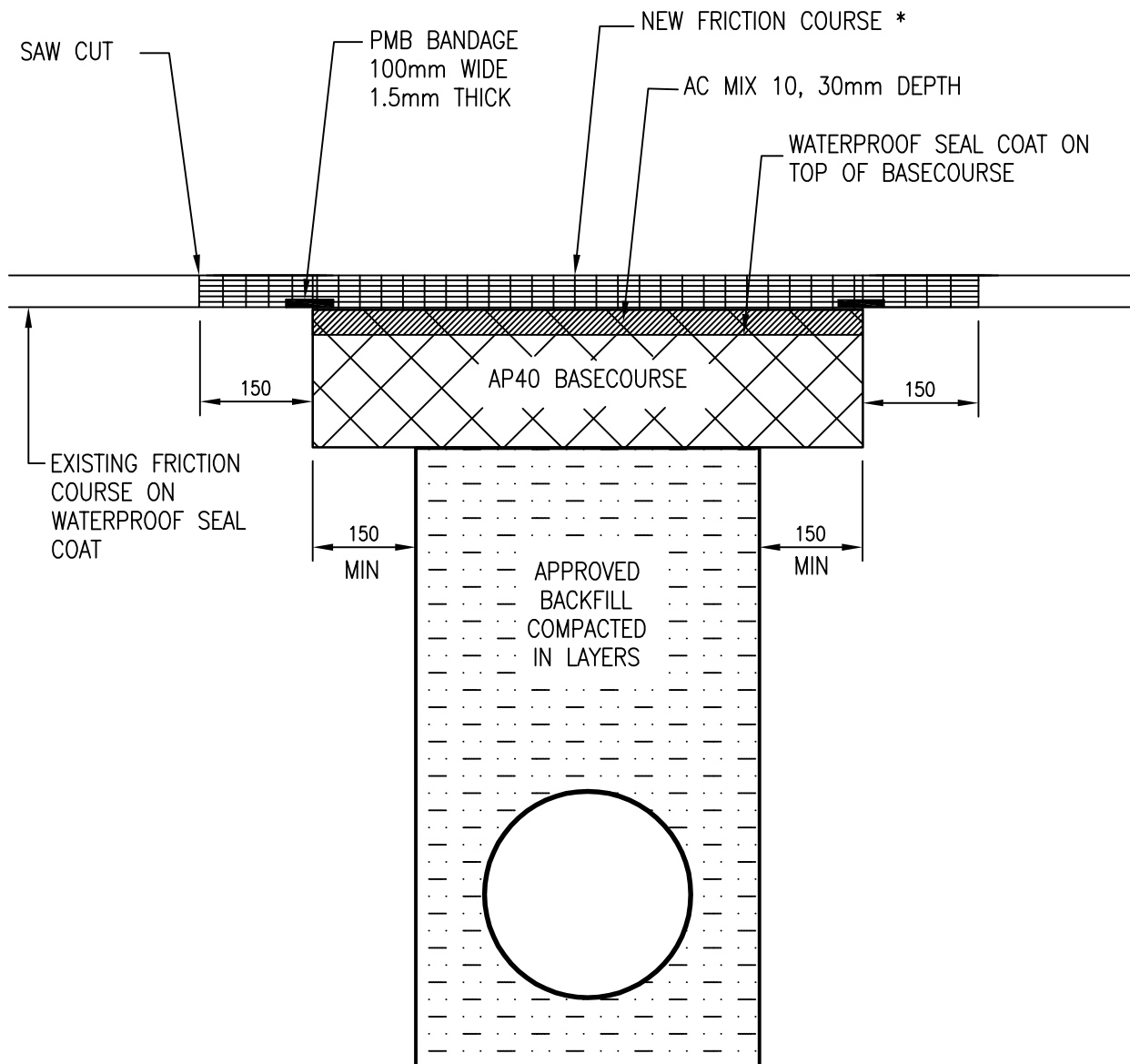

FOR FRICTION COURSE

1. FOR FINISHED SEAL LEVEL TOLERANCES SEE X-6(B) (PG 92).
2. *DEPTH TO MATCH EXISTING BITUMINOUS LAYER DEPTH, WHERE DEPTH IS GREATER THAN 50MM.

**NELSON
CITY
COUNCIL**

TRENCH REINSTATEMENT IN CARRIAGEWAY (FRICTION COURSE)

ASSET MANAGEMENT DIVISION

APPROVED

MANAGER INFRASTRUCTURAL ASSETS

Jan. 2003

DATE

PLAN No.

21/700

SHEET 3

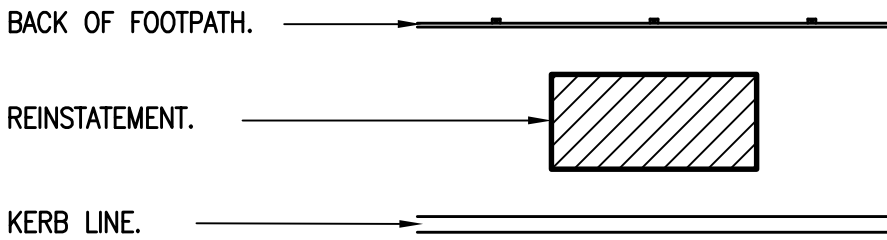

NOT APPROVED

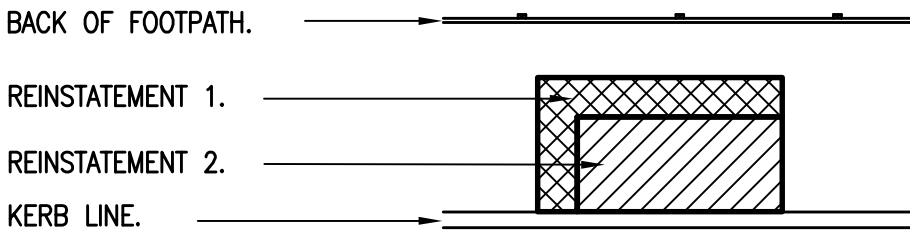

NOT APPROVED

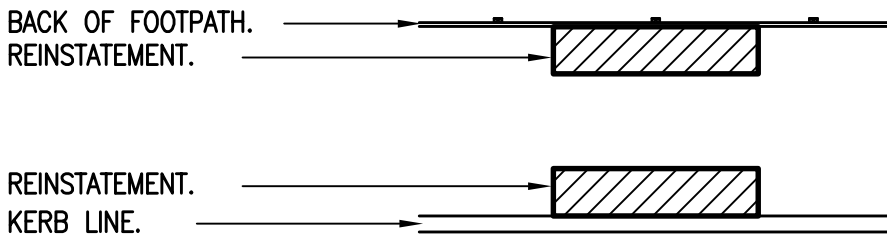

NOT APPROVED

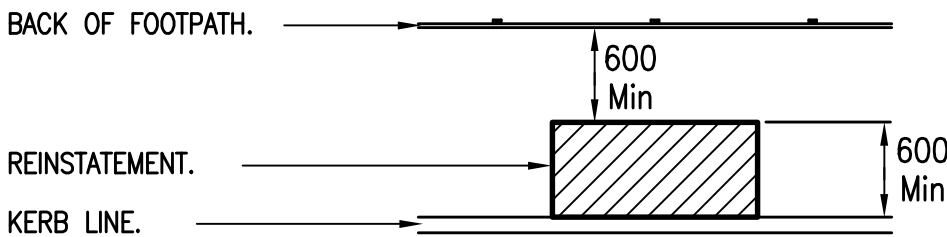

APPROVED
(Excluding Arterial & Principal roads & CBD areas)

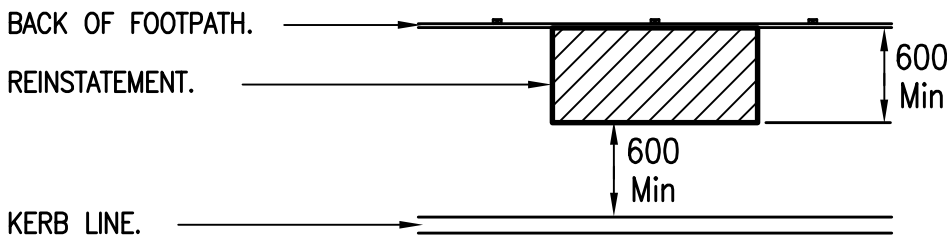

APPROVED
(Excluding Arterial & Principal roads & CBD areas)

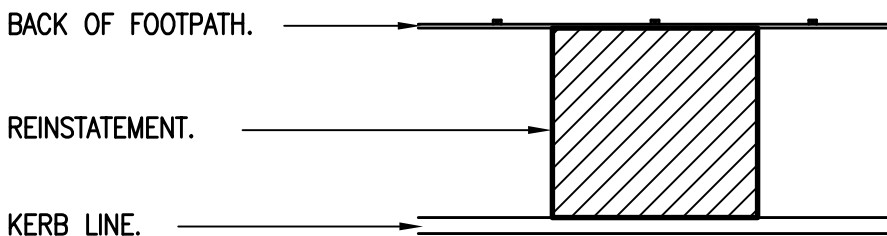

APPROVED

**NELSON
CITY
COUNCIL**

FOOTPATH SURFACE REINSTATEMENT

ASSET MANAGEMENT DIVISION

APPROVED

MANAGER INFRASTRUCTURAL ASSETS

Jan. 2003

DATE

PLAN No.

21/701

SHEET 1