

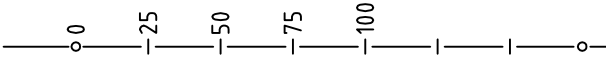

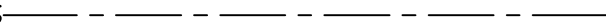

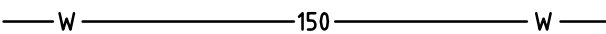

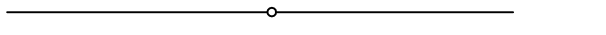
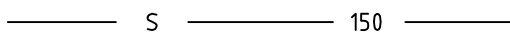
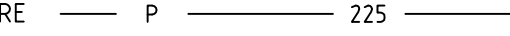

STANDARD SYMBOLS

| | | |
|---------------------------|---|--|
| <u>SURVEY LINES</u> |  | |
| <u>LAND BOUNDARIES</u> |  | LINEWEIGHT 0.25mm |
| <u>WATERMAINS</u> |  | CIRCLE DIA 2mm |
| HYDRANTS |  | LINEWEIGHT 0.25mm |
| VALVES |  | LINEWEIGHT 0.35mm |
| <u>SOIL SEWERS</u> | | PIPE DIAMETER AT PERIODIC INTERVALS ALONG THE LINE |
| GRAVITY |  | LINEWEIGHT 0.25mm |
| SWALLOWS OR PRESSURE |  | LINE LENGTH 20mm |
| RISING OR PUMPING |  | LINE GAP 10mm |
| MANHOLE |  | LINEWEIGHT 0.35/0.5mm |
| <u>STORMWATER SEWER</u> | | DIA'S 2&3mm |
| MAIN |  | LINEWEIGHT 0.35/0.5mm |
| MANHOLE |  | DIA'S 2&3mm |
| OPEN DRAINS |  | LINEWEIGHT 0.25mm |
| <u>CABLES</u> | | |
| TELEPHONE UNDERGROUND |  | LINEWEIGHT 0.35/0.5mm |
| OVERHEAD |  | DIA 2mm |
| ELECTRICITY UNDERGROUND |  | LINEWEIGHT 0.25mm |
| OVERHEAD |  | DIA 2mm |
| <u>KERB & CHANNEL</u> |  | LINEWEIGHT 0.5mm |
| <u>SUMPS</u> |  | |
| <u>RETAINING WALLS</u> |  | LINEWEIGHT 0.25mm |

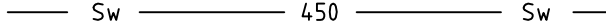
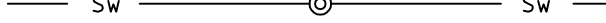
ANNOTATED e.g CRIBWALL

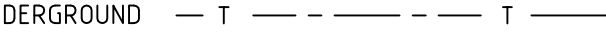
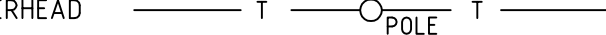
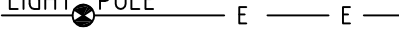
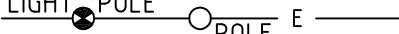
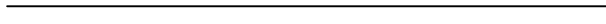
TYPICAL SIGNATURE BLOCK

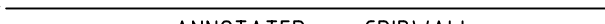
| | |
|--------------------------------|--------------|
| ASSET MANAGEMENT DIVISION | NCC PLAN No. |
| MANAGER INFRASTRUCTURAL ASSETS | DATE |
| SHEET | OF |

SITE CONTOURS 1:1000 1:500 1:250 1:200

STREETS KERB & CHANNEL AND

FOOTPATHS

PLAN 1:500 1:250 1:200

LONGITUDINAL SECTION :

 HORIZONTAL 1:500 1:250 1:200

 VERTICAL 1:50 1:25 1:20

CROSS SECTIONS

 HORIZONTAL 1:50

 VERTICAL 1:100 1:50 1:20

SOIL & STORMWATER SEWERS

PLAN 1:500 1:250 1:200

LONGITUDINAL SECTION :

 HORIZONTAL 1:500 1:250 1:200

 VERTICAL 1:50 1:100

DETAILS 1:20 1:10 1:5

SERVICES GENERAL

PLAN 1:500 1:250 1:200

CROSS SECTIONS 1:50

ANY VARIATION FROM THESE SCALES AS SHOWN SHALL HAVE THE PRIOR APPROVAL OF THE COUNCIL

SHEET SIZES: A1 594mm x 841mm

 A2 420mm x 594mm

MAIN SHEETS REQUIRED:

1. ROADING
2. SEWERS - STORMWATER - KERBS
3. WATER - TELEPHONE - POWER - KERBS

ALL INKS AND LETTERING USED SHOULD BE SUITABLE FOR MICROFILM and SCANNING REPRODUCTION.

NELSON
CITY
COUNCIL

DRAUGHTING SYMBOLS & SCALES

ASSET MANAGEMENT DIVISION

APPROVED



MANAGER INFRASTRUCTURAL ASSETS

Jan. 2003

DATE

PLAN No.

21/100

SHEET 1

LONGITUDINAL SECTION

ROADS

| | |
|---|----------|
| H.A.D (N.C.C.) | |
| OTHER LEVELS (E.G. EXISTING SERVICES) | |
| TOP OF KERB LEVEL R.H. SIDE | |
| TOP OF KERB LEVEL L.H. SIDE | |
| GROUND LEVEL PEG LEVEL | |
| HORIZONTAL DISTANCE | |
| GRADIENT R.H SIDE (% OR 1 IN _) | ← V.C. → |
| GRADIENT L.H SIDE | |
| HORIZONTAL CURVE | ← H.C. → |

NOTE

1. ALL LEVELS IN TERMS OF HEIGHT ABOVE NCC DATUM IN METRES
2. ALL DISTANCES IN METRES.
3. GROUND OR PEG LEVELS SHOWN ON SECTIONS ARE TO BE THOSE ON THE LINE OF THE SEWER
4. PIPELINES DESIGNED TO OPERATE UNDER PRESSURE SHALL INCLUDE THE HYDRAULIC GRADE LINE, ITS LEVELS AND GRADIENTS.
5. BLOCKS MAYBE EXTENDED TO ALLOW "AS BUILT" DATA TO BE ADDED.
e.g: AS BUILT SEWER
INVERT
AS BUILT DISTANCE
AS BUILT GRADIENT

SEWER & STORMWATER



| | |
|---|--|
| H.A.D (N.C.C.) | |
| OTHER LEVELS (E.G. SERVICES CROSSING THE LINE) | |
| HYDRAULIC GRADE LEVEL (IF APPLICABLE) | |
| GROUND LEVEL PEG LEVEL | |
| CUT (GROUND LEVEL TO INVERT.) | |
| SEWER INVERT | |
| SEWER DISTANCE (TRUE HORIZONTAL DISTANCE ALONG SEWER) | |
| GRADIENT (% OR 1 IN _) | |
| DIAMETER (MILLIMETERS.) | |

COLOUR CODE

COLOUR CODE PRIMARILY FOR USE ON WHITE PAPER. ALL INKS USED SHOULD BE SUITABLE FOR DYELINE PHOTOCOPYING AND MICROFILMING REPRODUCTION.

SYMBOL IS FOR WHEN COLOURS ARE TO BE REPRODUCED IN BLACK

COLOUR CODE FOR EARTHWORKS IN SECTION

| | | | |
|--------------------|-------|----------|---|
| FILLING | GREEN | SYMBOL = |  |
| CUTTING | RED | SYMBOL = |  |
| REPLACEMENT GRAVEL | BROWN | SYMBOL = |  |
| BASECOURSE | BLUE | SYMBOL = |  |

NELSON
CITY
COUNCIL

DRAUGHTING STANDARDS & SYMBOLS

ASSET MANAGEMENT DIVISION

APPROVED 

.....
MANAGER INFRASTRUCTURAL ASSETS

Jan. 2003
DATE

PLAN No.
21/100
SHEET 2

TIMES FOR SURFACE FLOW

INFRASTRUCTURE DIVISION

APPROVED

.....
MANAGER INFRASTRUCTURAL ASSETS DATE

PLAN No.

21/200

SHEET 1

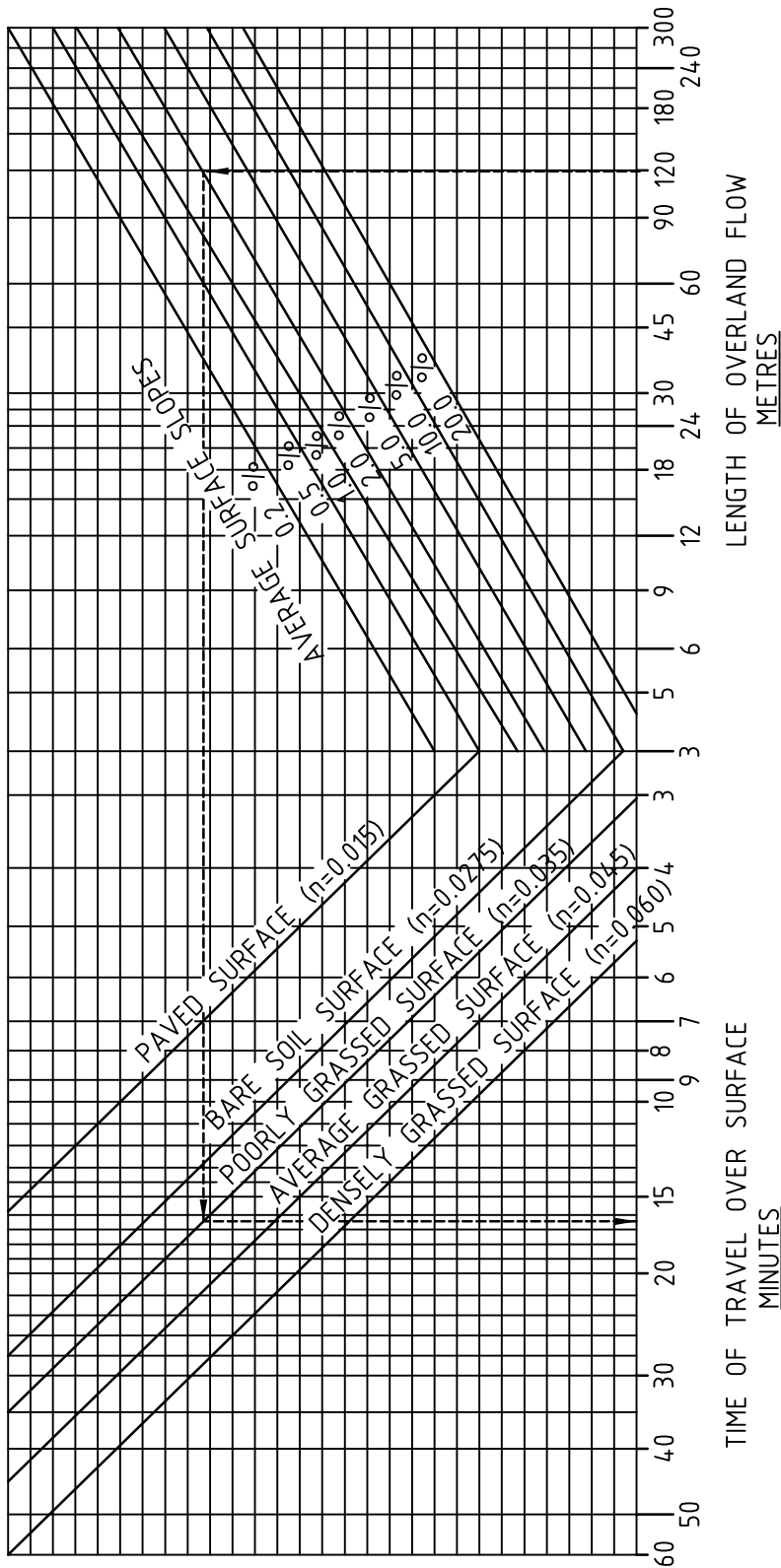

FORMULA $t = \frac{107n\sqrt{\ell}}{\sqrt{S}}$ MINUTES

WHERE t = TIME OF TRAVEL OVER SURFACE IN MINUTES DATA ATTRIBUTED TO U.S. DEPT OF AGRICULTURE 1942.
n = HORTON'S VALUES FOR THE SURFACE NOMOGRAPH PUBLISHED IN "MUNICIPAL UTILITIES" SEPTEMBER 1951.
ℓ = LENGTH OF FLOW IN METRES
S = SLOPE OF SURFACE IN %

EXAMPLE

LENGTH OF OVERLAND FLOW = 120m
AVERAGE SLOPE OF SURFACE = 2%
POORLY GRASSED SURFACE
∴ TIME OF TRAVEL = 16.3 MINUTES

FORMULA AND VALUES OF "n" ADDED BY J.A. FRIEND
19th NOVEMBER 1954.

NELSON CITY COUNCIL

RAINFALL INTENSITY CURVE

INFRASTRUCTURE DIVISION

APPROVED

MANAGER INFRASTRUCTURAL ASSETS DATE

PLAN No.

21/201

SHEET 1

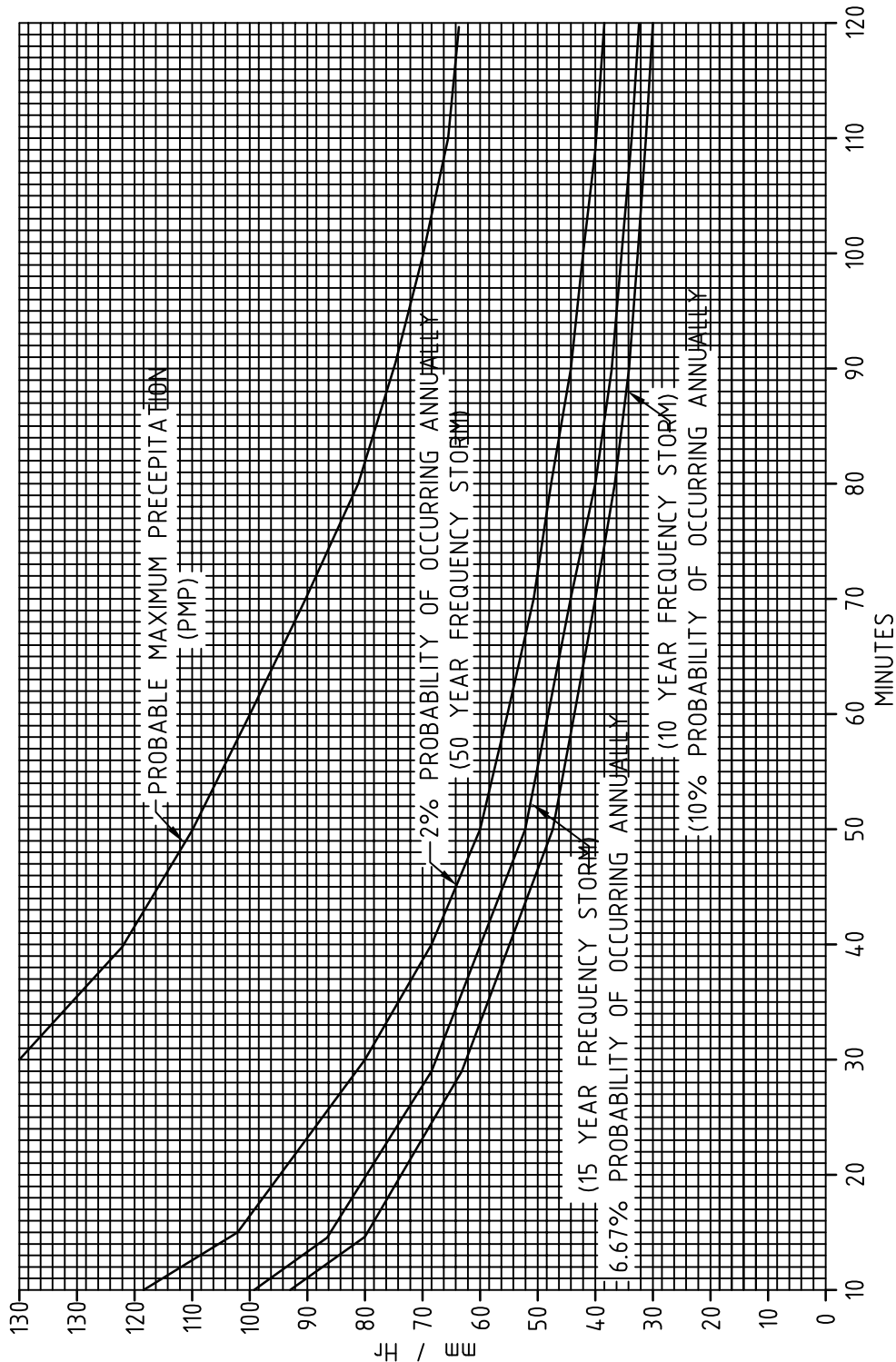

RAINFALL INTENSITY CURVES

REVISED NOVEMBER 1976 BASED ON TECHNICAL MEMORANDUM
 61 READINGS AT NELSON AIRPORT REVISED AUGUST 1974
 THIS SUPERSEDES 21/12
 10% PROBABILITY CURVE ADDED NOV 1992
 PMP CURVE ADDED OCT 1997

RUN OFF CO-EFFICIENTS

| | |
|-------------------------|------|
| RURAL | 0.4 |
| RESIDENTIAL | 0.55 |
| INDUSTRIAL & COMMERCIAL | 0.8 |

CONVERSION FACTORS

| | |
|----------------------|-------|
| 50 YEAR FREQUENCY TO | 0.880 |
| 20 YEAR | 0.845 |
| 15 YEAR | 0.790 |
| 10 YEAR | 0.490 |
| 5 YEAR | 0.490 |

THE COUNCIL ACCEPTS RESPONSIBILITY FOR ANY SEWER LINE MORE THAN 15m FROM THE BOUNDARY OF THE LAST PROPERTY SERVED (CROSS LEASED UNITS ARE CONSIDERED ONE PROPERTY)

_____ PUBLIC SEWER
 - - - - - PRIVATE SEWER
 ⊗ LHCE
 ● INSPECTION 'T'
 (100mm 'T' JUNCTION VERTICAL INSPECTION PIPE.
 SEE NCC STD DWG 21/205 SHEET 4.)

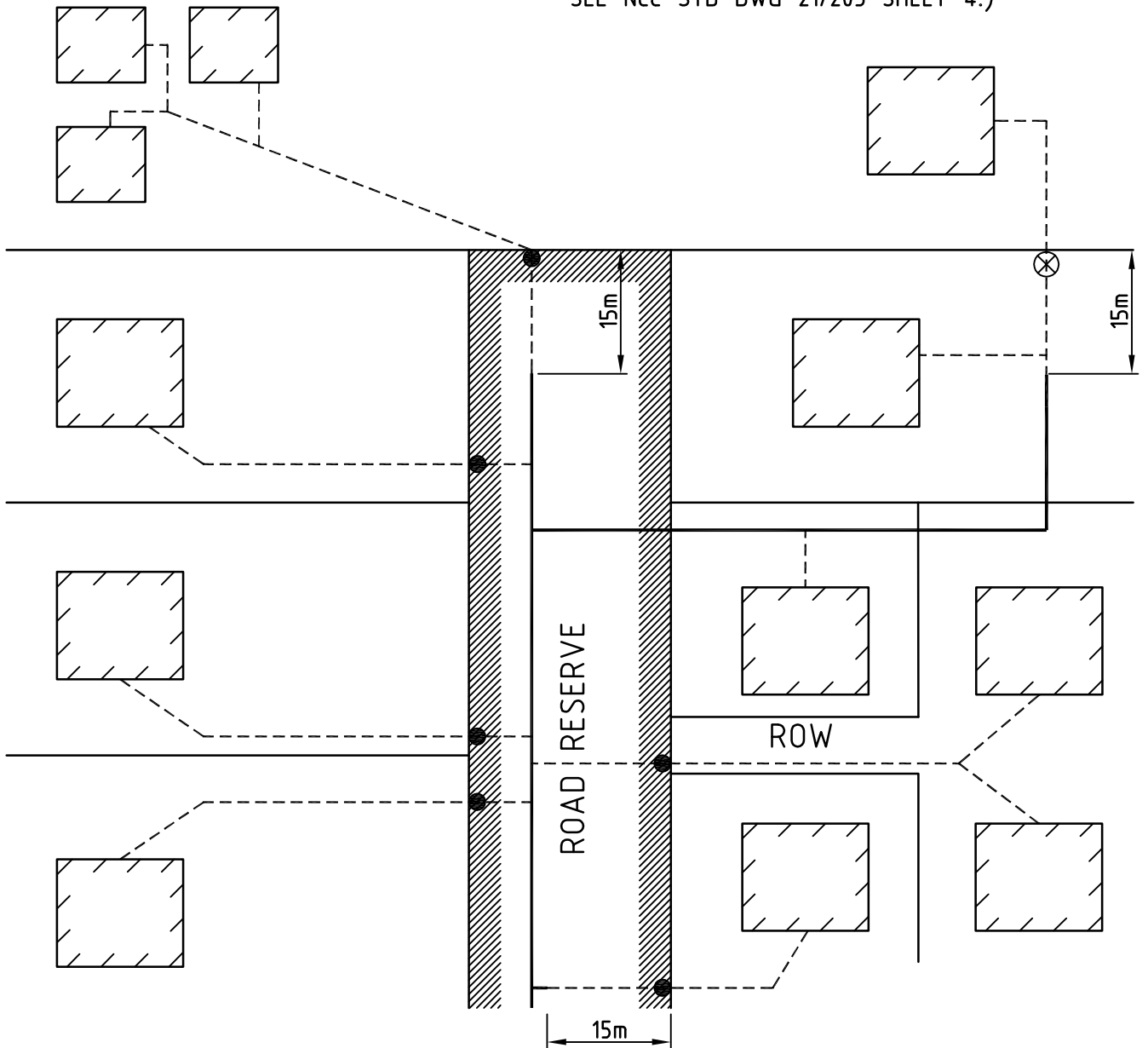

**NELSON
CITY
COUNCIL**

DEFINITION OF PUBLIC SEWER

INFRASTRUCTURE DIVISION

PLAN No.

APPROVED

21/202

.....
MANAGER INFRASTRUCTURAL ASSETS DATE

SHEET 1

NOTES

1. SKEW AND/OR VERY STEEP APPROACH INLETS WILL REQUIRE DETAIL DESIGN BASED ON THIS STANDARD.
2. REINFORCING IS MINIMUM AND RETAINING WALL MUST BE DESIGNED FOR INDIVIDUAL CIRCUMSTANCES.
3. ALL REINFORCEMENT TO BE PLACED CENTRALLY IN WALLS AND FLOOR AND TO BE CONTINUOUS BETWEEN WALLS AND BETWEEN FLOOR AND WALLS.
4. AT LEAST 2 HORIZONTAL BARS TO BE PLACED OVER THE PIPE IN THE END WALL.
5. GRADE OF APRON TO BE NOT LESS THAN GRADE OF PIPE.
6. DIMENSIONS OF GRILL TO BE FULLY DETAILED FOR EACH CASE.
7. FULL HEADWALLS AND SIDEWALLS TO BE PROVIDED AS CASE REQUIRES IN ADDITION TO MINIMUM REQUIREMENT SHOWN.
8. THIS STANDARD SHOWS MINIMUM REQUIREMENTS : THE DETAILS OF CHANNEL APPROACH : DEPTH, STABILITY OF GROUND AND OTHER FACTORS IN EACH CASE MUST BE TAKEN INTO ACCOUNT IN THE DESIGN.

* ALTERNATIVE TO SOCKET END OF PIPE

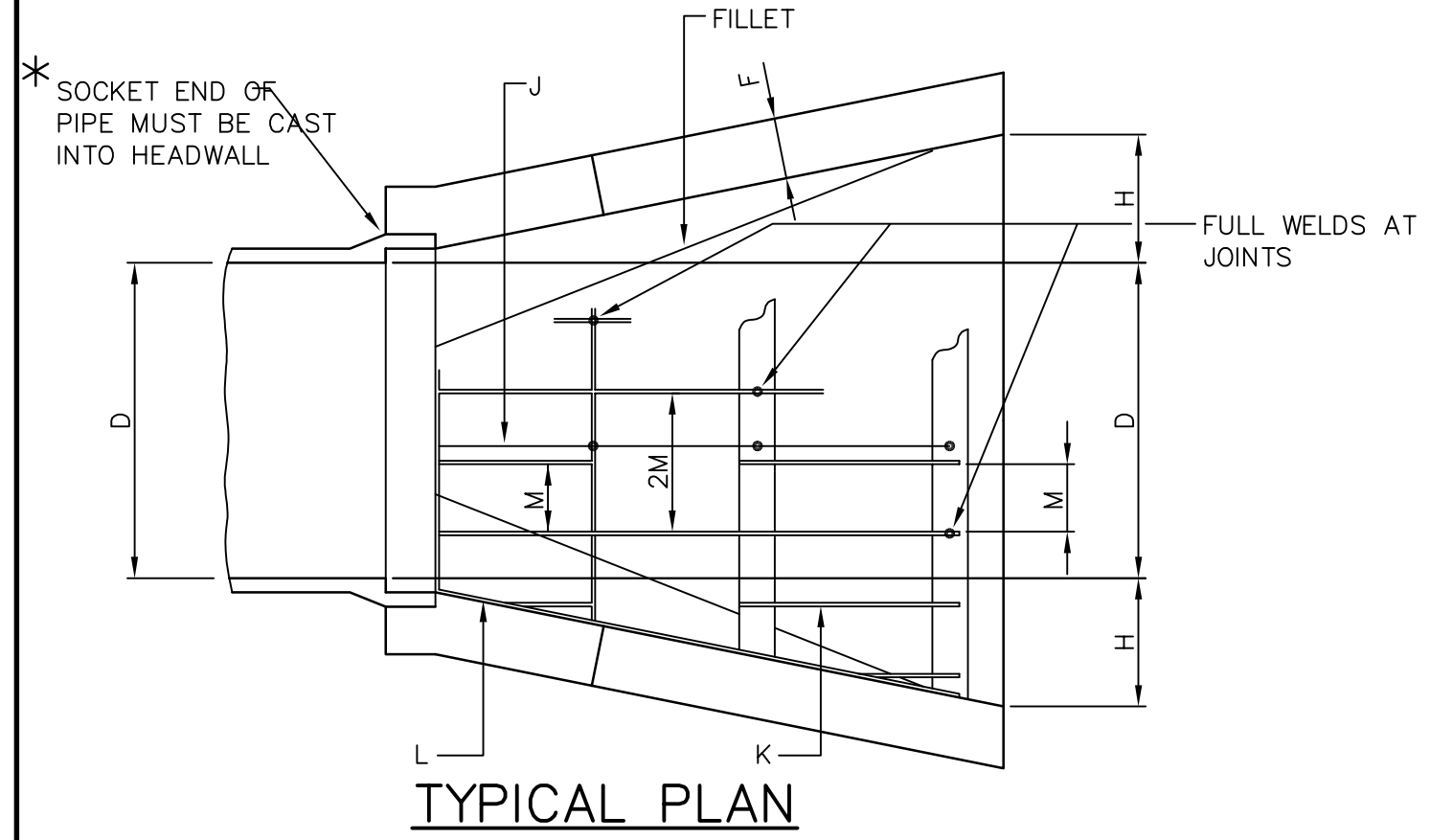
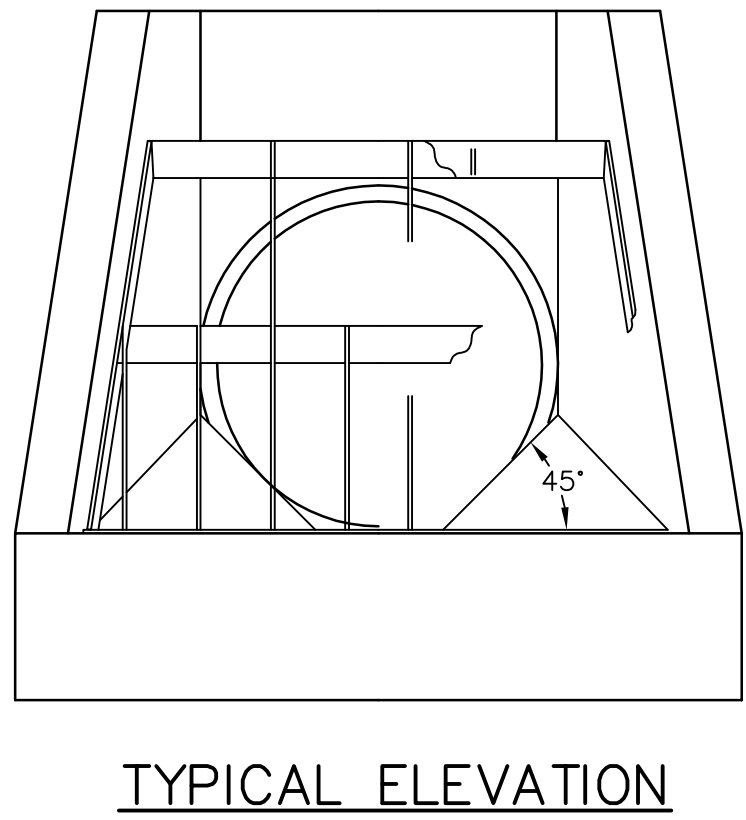
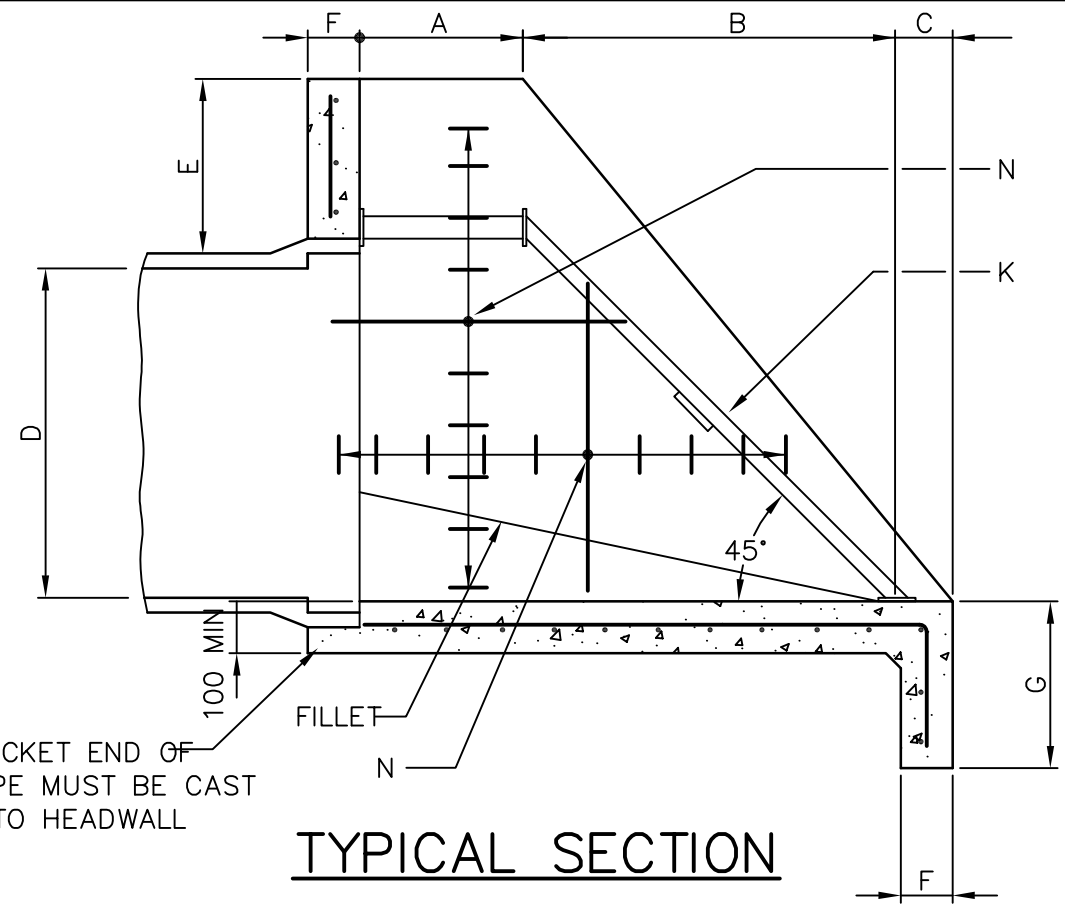
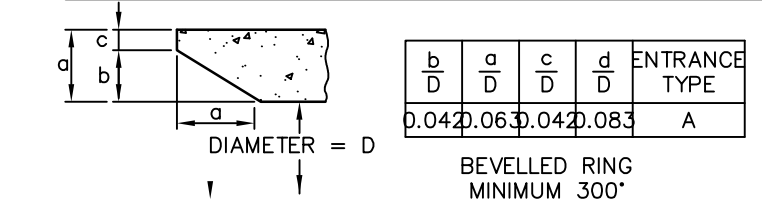

| PIPE INLET SCHEDULE | | | | | | | | | | | | | | | | |
|---------------------|---|----------|----------|-----------|-----------|-----------|-----------|-----------|--|-----------|-----------|-----------|-----------|-----------|-----------|--|
| NOMINAL PIPE DIA | 300 | 375 | 450 | 525 | 600 | 675 | 750 | 825 | 900 | 1075 | 1200 | 1350 | 1500 | 1575 | 1800 | |
| DETAIL A | 300 | 300 | 300 | 300 | 400 | 400 | 400 | 400 | 400 | 600 | 600 | 700 | 700 | 800 | 800 | |
| B | 500 | 500 | 600 | 700 | 800 | 800 | 900 | 1000 | 1100 | 1200 | 1400 | 1500 | 1700 | 1800 | 2000 | |
| C min | 150 | 150 | 150 | 150 | 150 | 150 | 150 | 150 | 150 | 150 | 150 | 150 | 150 | 150 | 150 | |
| D | 305 | 381 | 457 | 533 | 610 | 686 | 762 | 833 | 914 | 1067 | 1219 | 1372 | 1524 | 1600 | 1829 | |
| E min | 300 | 300 | 450 | 450 | 450 | 450 | 450 | 450 | 450 | 450 | 450 | 450 | 450 | 450 | 450 | |
| F min | 150 | 150 | 150 | 150 | 150 | 150 | 150 | 150 | 150 | 150 | 150 | 150 | 150 | 150 | 150 | |
| G min | 400 | 400 | 400 | 400 | 500 | 500 | 500 | 500 | 500 | 600 | 600 | 600 | 600 | 600 | 600 | |
| H min | 300 | 300 | 300 | 300 | 400 | 400 | 400 | 400 | 400 | 500 | 500 | 500 | 600 | 600 | 600 | |
| J | 75x10 MS | 75x10 MS | 75x10 MS | 100x10 MS | 100x10 MS | 100x10 MS | 100x10 MS | 100x10 MS | 100x10 MS | 100x10 MS | 100x10 MS | 100x10 MS | 100x10 MS | 100x10 MS | 100x10 MS | |
| K | 25x10 MS | 25x10 MS | 25x10 MS | 50x10 MS | 50x10 MS | 50x10 MS | 50x10 MS | 50x10 MS | 50x10 MS | 50x10 MS | 50x10 MS | 50x10 MS | 50x10 MS | 50x10 MS | 50x10 MS | |
| L | 50x10 MS | 50x10 MS | 50x10 MS | 75x10 MS | 75x10 MS | 75x10 MS | 75x10 MS | 75x10 MS | 75x10 MS | 75x10 MS | 75x10 MS | 75x10 MS | 75x10 MS | 75x10 MS | 75x10 MS | |
| M | 200 | 200 | 200 | 200 | 200 | 200 | 200 | 200 | 200 | 200 | 200 | 200 | 200 | 200 | 200 | |
| N | ← 6mm dia bars at 150 crs EW or equivalent mesh → | | | | | | | | ← 10mm dia bars at 150 crs EW or equivalent mesh → | | | | | | | |
| H.D BOLTS LINTEL | 2x12 dia | 2x12 dia | 2x12 dia | 2x12 dia | 2x12 dia | 2x12 dia | 2x12 dia | 2x12 dia | 3x12 dia | 3x12 dia | 3x12 dia | 4x12 dia | 4x12 dia | 4x12 dia | 4x12 dia | |
| H.D BOLTS APRON | 3x12 dia | 3x12 dia | 3x12 dia | 4x12 dia | 4x12 dia | 4x12 dia | 4x12 dia | 4x12 dia | 5x12 dia | 5x12 dia | 5x12 dia | 6x12 dia | 6x12 dia | 6x12 dia | 6x12 dia | |

APPROVED PRECAST INLET STRUCTURES MAY BE USED

| | | |
|----------------------------|---|----------|
| NELSON CITY COUNCIL | TYPICAL STORMWATER INTAKE STRUCTURE DETAILS | |
| | INFRASTRUCTURE DIVISION | PLAN No. |
| | APPROVED MANAGER INFRASTRUCTURAL ASSETS | DATE |

21/203

SHEET 1

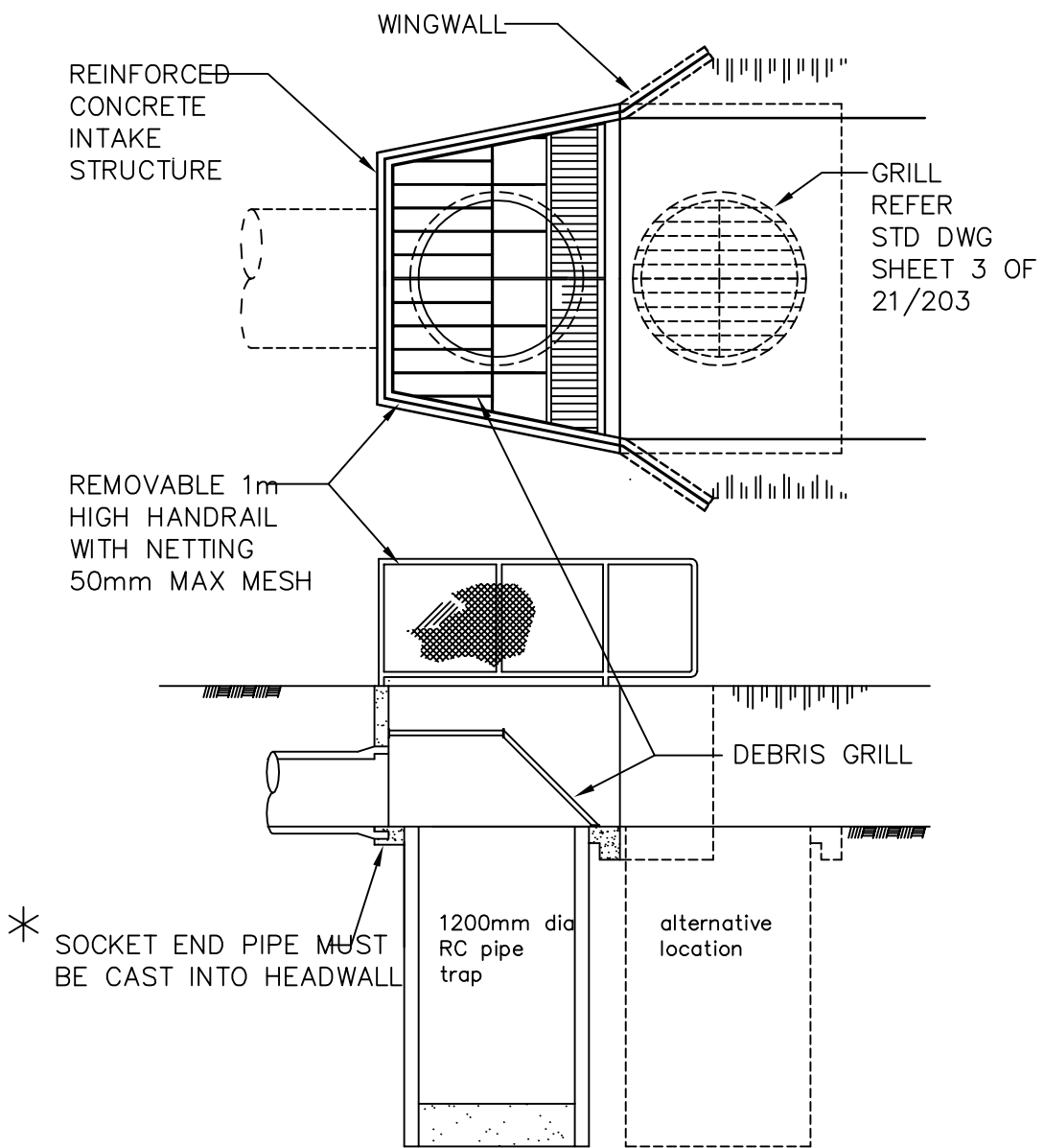

TYPE A DEEP TRAP SUMP

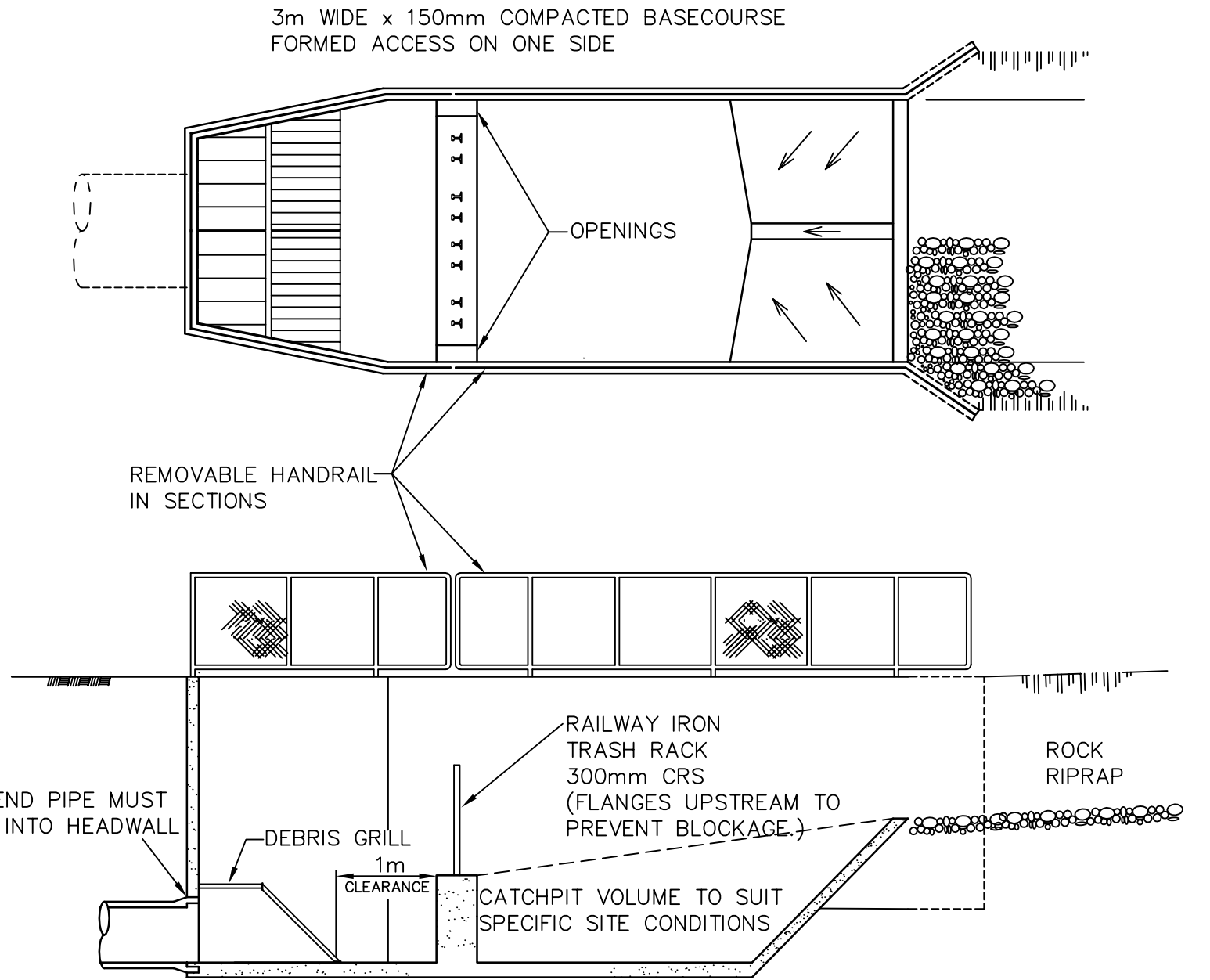

TYPE B RAILWAY IRON TRASH RACK & CATCHPIT

REINFORCED CONCRETE STRUCTURE REQUIRING SPECIFIC DESIGN.

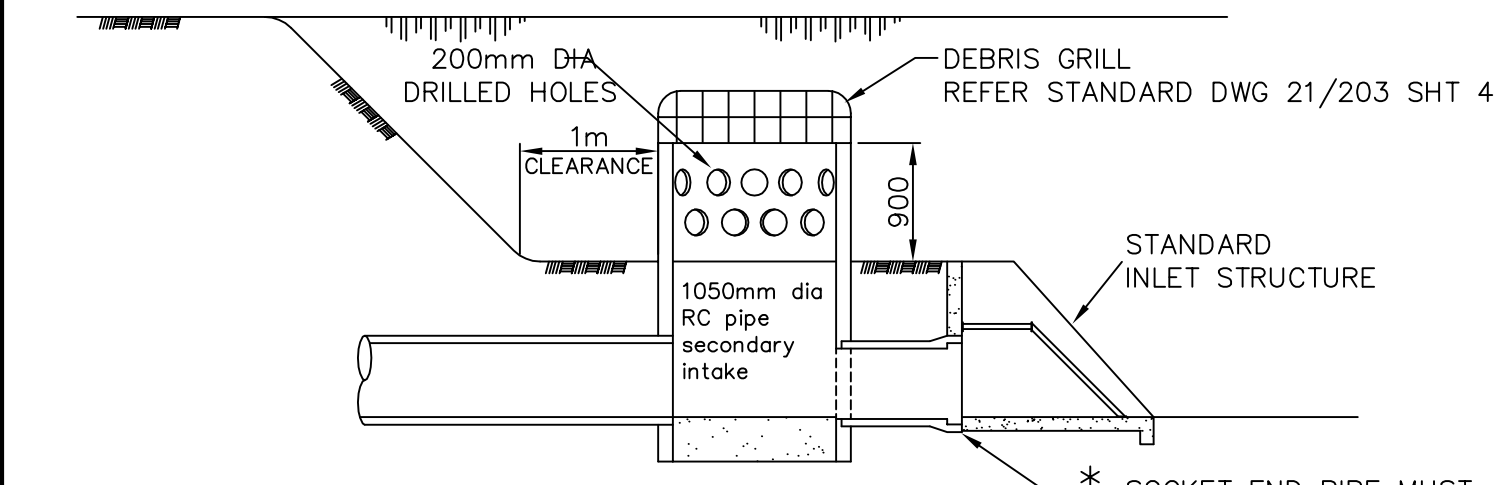

TYPE C SECONDARY INTAKE

NOTES

- 1. TYPES A,B,C AS SHOWN ARE GENERAL EXAMPLES - EACH CASE WILL REQUIRE DESIGN TO SUIT THE SITE WITH REGARD TO PEAK FLOWS AND ANTICIPATED DEBRIS: FINAL DETAILS SHALL BE SUBMITTED TO THE ENGINEER FOR APPROVAL
- * SEE SHEET 1 OF 21/203 FOR ALTERNATIVE

| | | |
|----------------------------|---|---------------|
| NELSON CITY COUNCIL | STORMWATER INTAKE STRUCTURES WITH DEBRIS TRAPS | |
| | INFRASTRUCTURE DIVISION | PLAN No. |
| | APPROVED MANAGER INFRASTRUCTURAL ASSETS | DATE |

21/203

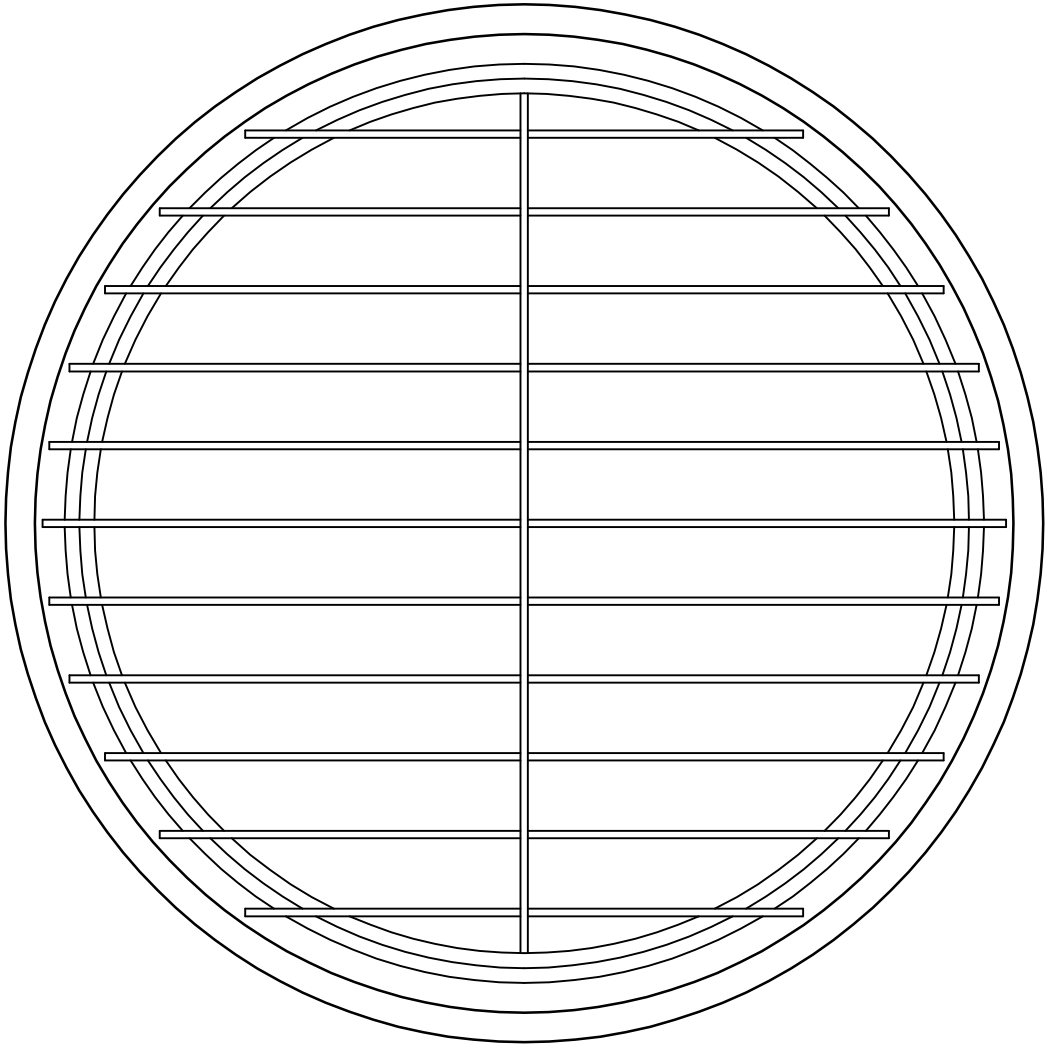

PLAN

50 x 10 AT 100 CENTRES
(50 CENTRES WHEN IN
RESIDENTIAL AREAS)

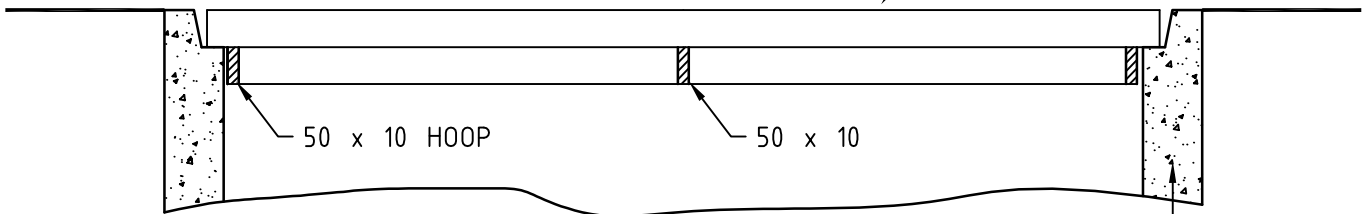

SECTION

1200mm DIA FLUSH JOINT
N.C PIPE

**NELSON
CITY
COUNCIL**

DEBRIS TRAP GRILL

INFRASTRUCTURE DIVISION

PLAN No.

APPROVED

21/203

.....
MANAGER INFRASTRUCTURAL ASSETS DATE

SHEET 3

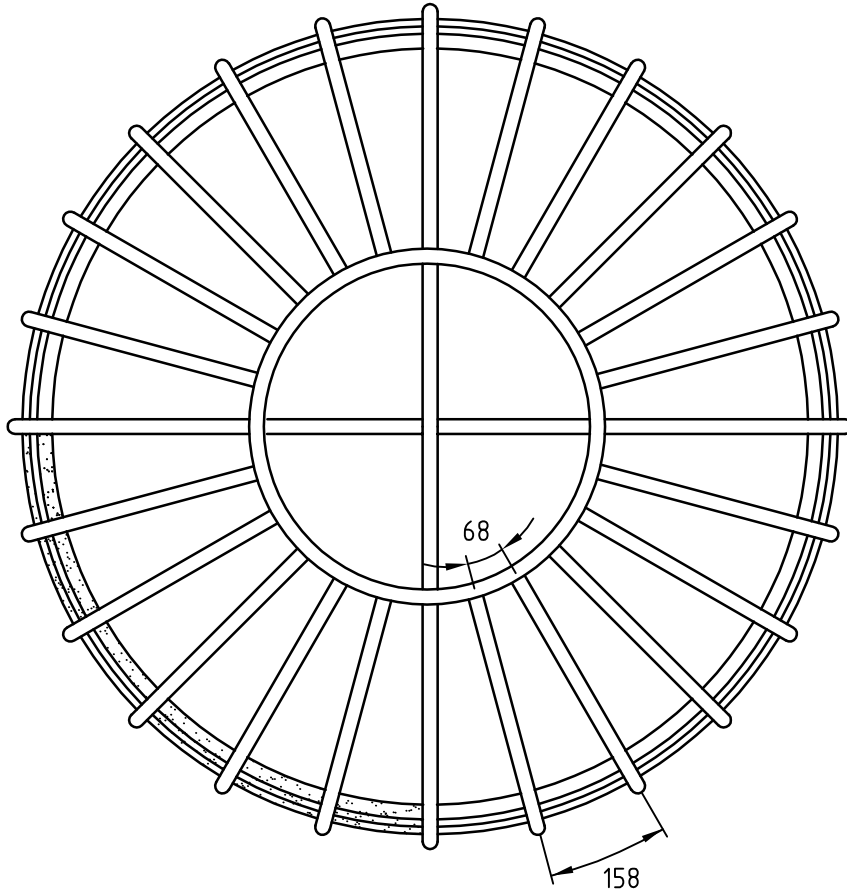

PLAN

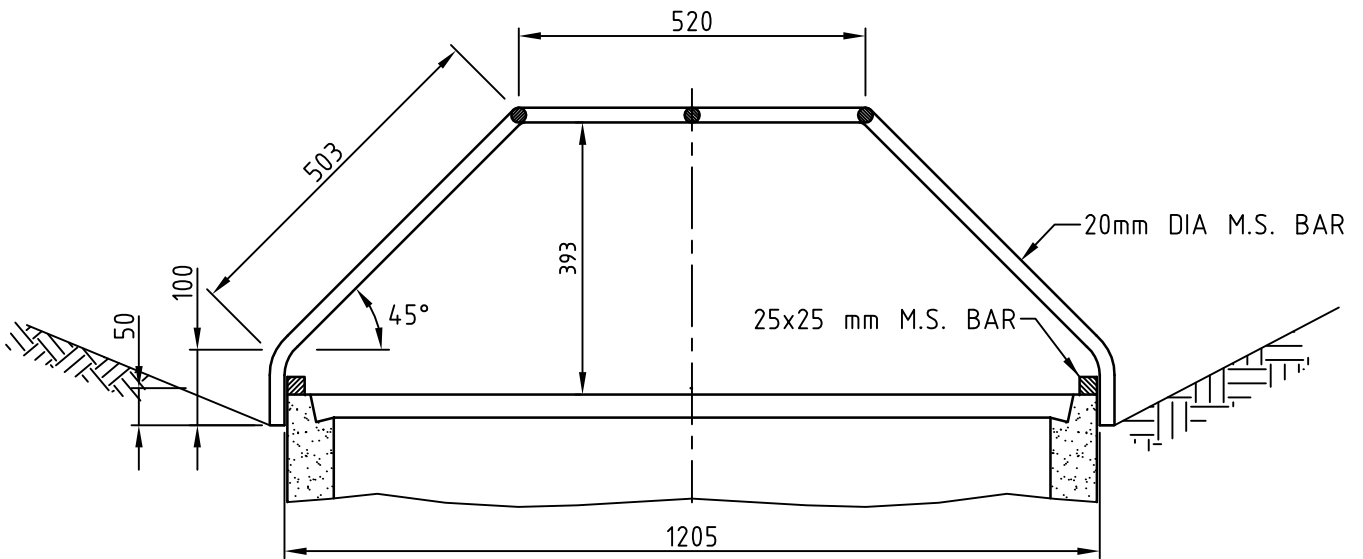

SECTION

**NELSON
CITY
COUNCIL**

SECONDARY INTAKE DEBRIS GRILL

INFRASTRUCTURE DIVISION

PLAN No.

APPROVED

21/203

.....
MANAGER INFRASTRUCTURAL ASSETS DATE

SHEET 4

NOTES

- ① ALL "INSITU" CONCRETE TO BE VIBRATED
- ② CONCRETE CRUSHING STRENGTH TO BE 20 MPa AFTER 28 DAYS
- ③ MAX DEPTH TO INVERT 4m
WALLS OVER 4m TO BE REINFORCED
- ④ MAX. SIZE OF PIPE TO BE 450 mm DIA FOR 1050mm MANHOLE
- ⑤ PRECAST CONCRETE MANHOLE RISERS SHALL COMPLY WITH THE REQUIREMENTS FOR CLASS 2 PRECAST CONCRETE PIPES TO AS/NZS 4058
- ⑥ MAXIMUM GRADIENT FOR HAUNCHING THROUGH MANHOLES SHALL BE 1 in 3

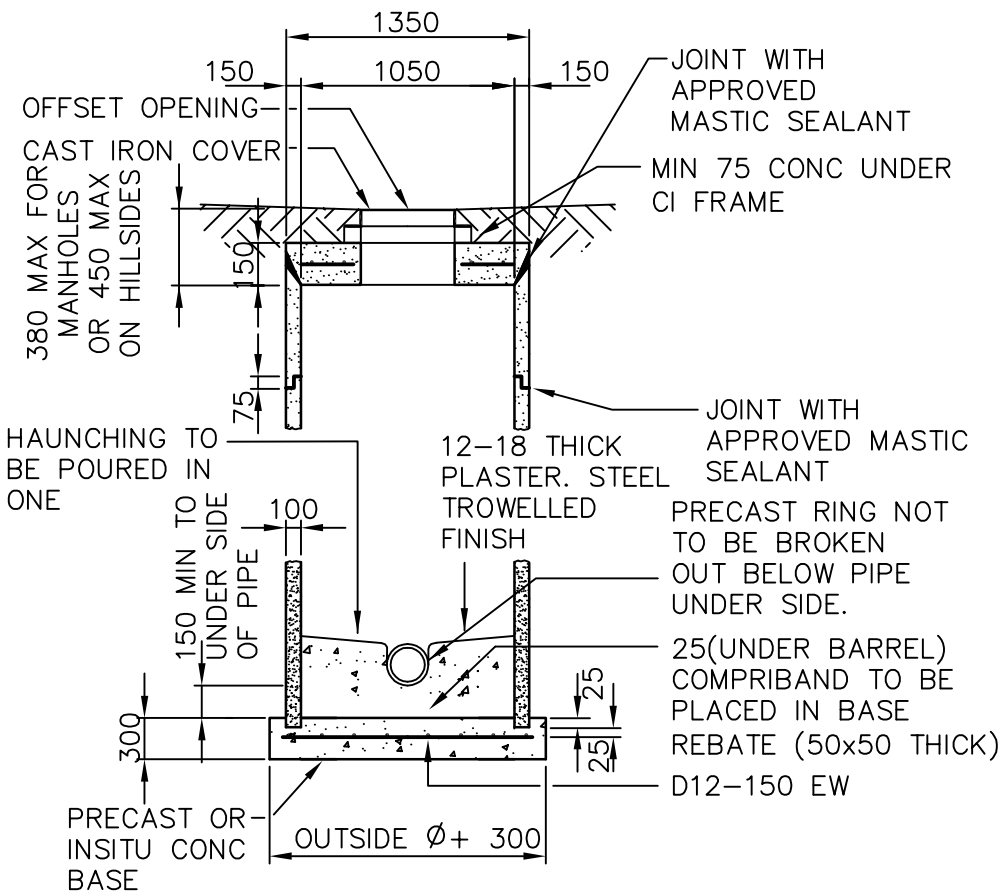

PRECAST MANHOLE DETAIL

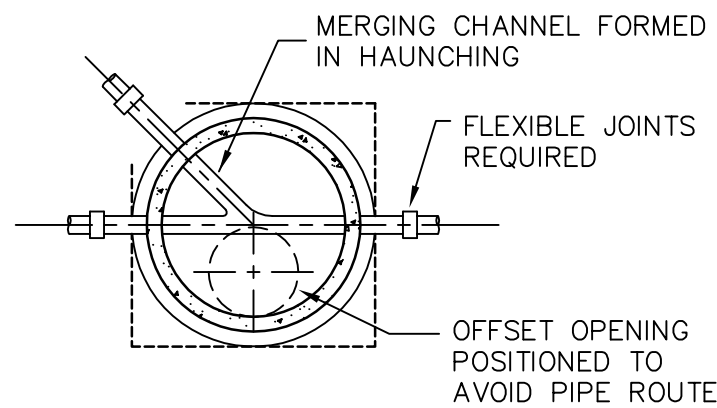

TYPICAL PLAN

FLEXIBLE JOINTS AT MANHOLES

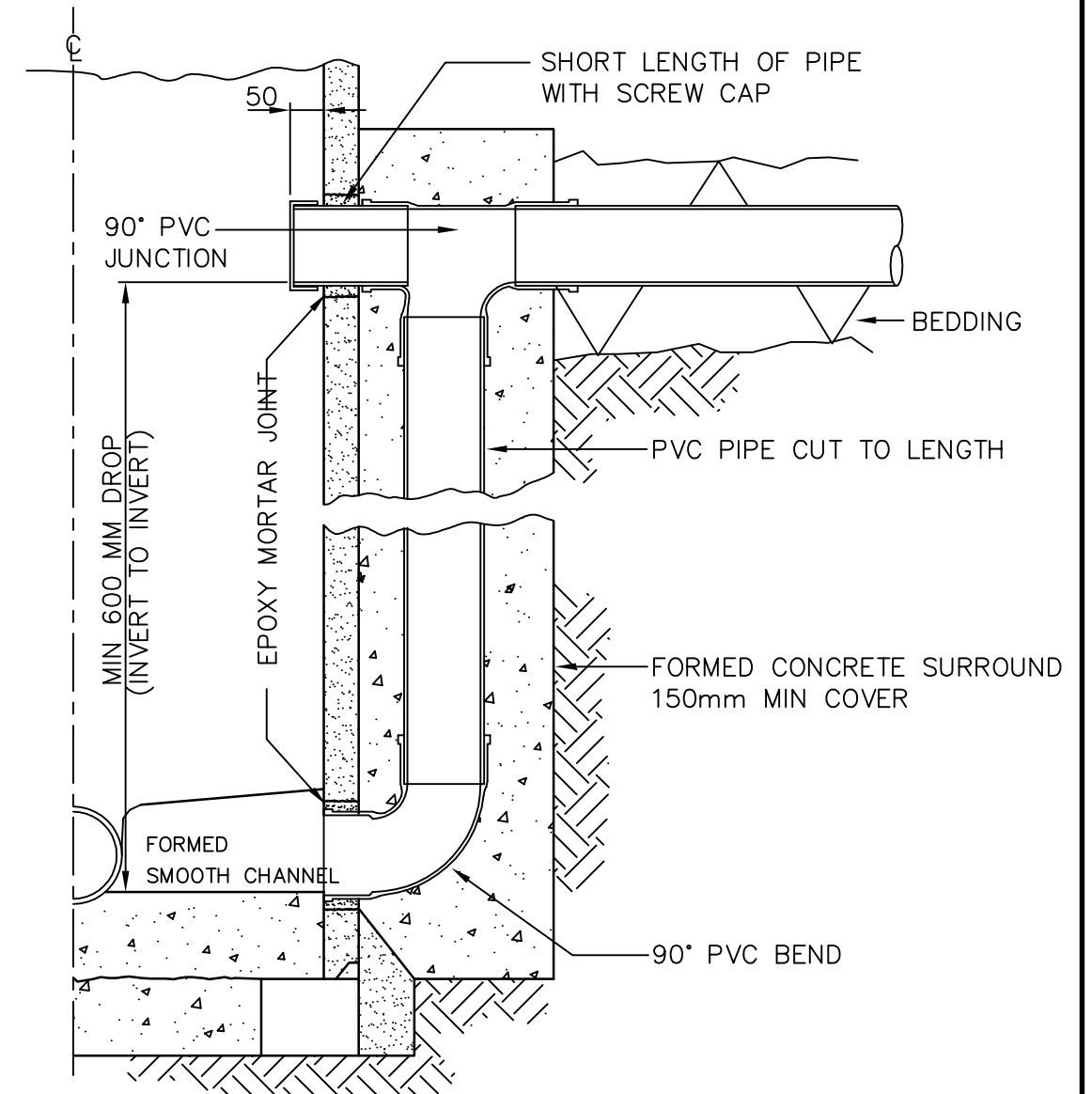
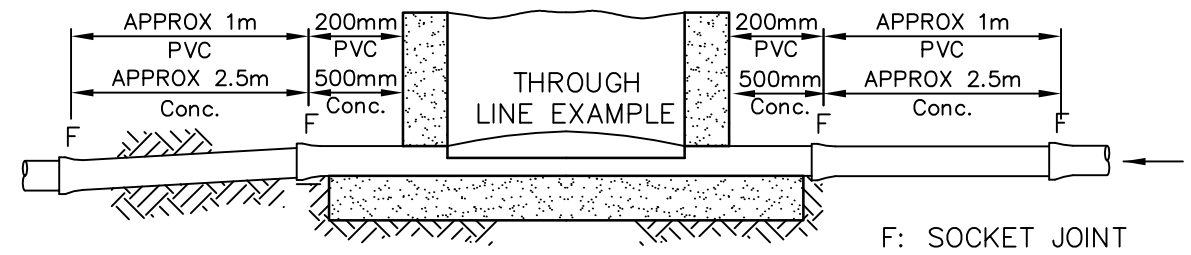

DROP MANHOLE DETAIL PVC 150Ø
(FOR DROPS LESS THAN 600mm SEE 21/204 SHEET 2)

NELSON CITY COUNCIL

1050Ø PRECAST MANHOLE DETAILS
for pipelines up to and incl. 450Ø

INFRASTRUCTURE DIVISION

APPROVED

MANAGER INFRASTRUCTURAL ASSETS DATE

PLAN No.

21/204

SHEET 1

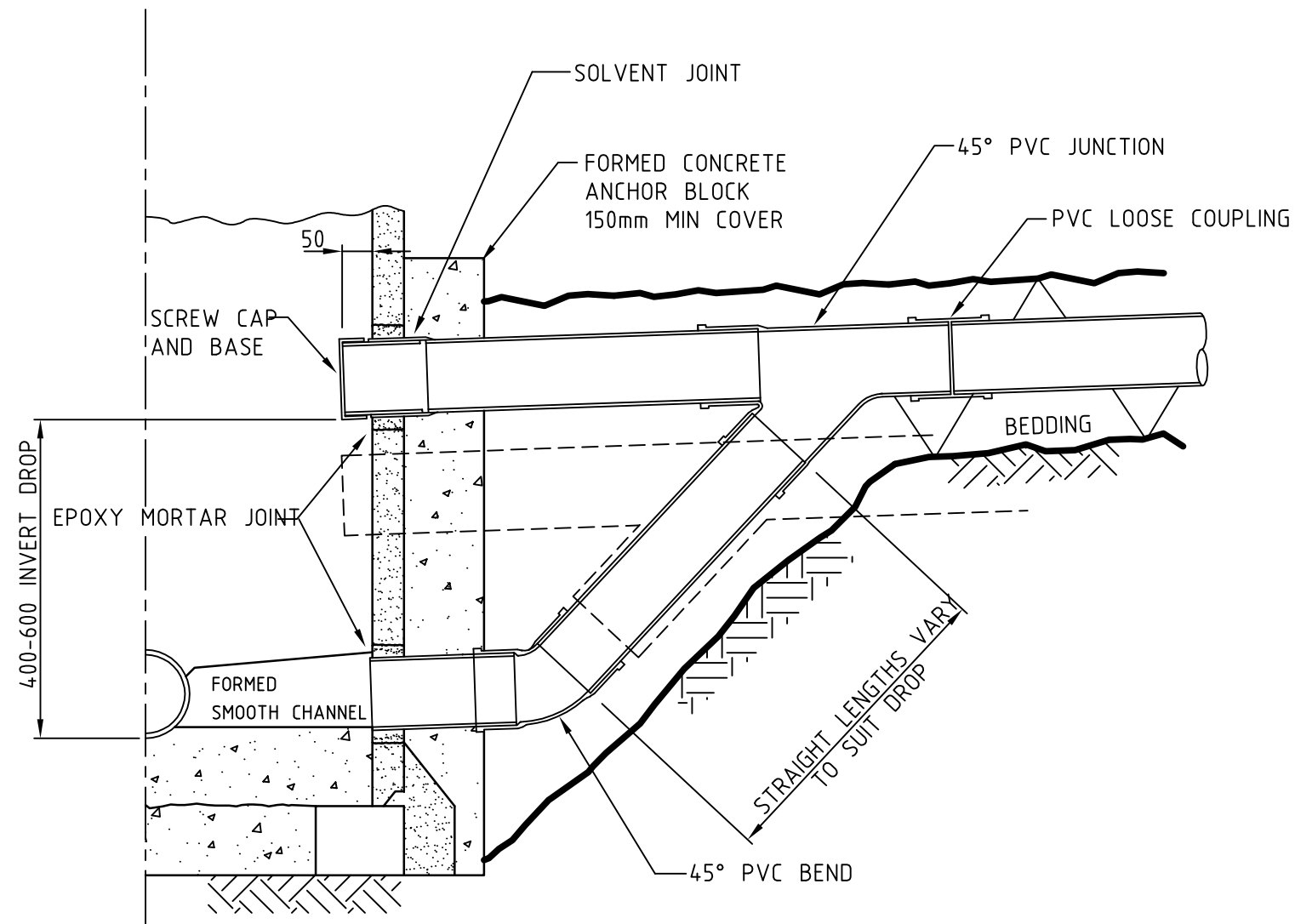

CASE OF DROP OF 400-600 mm

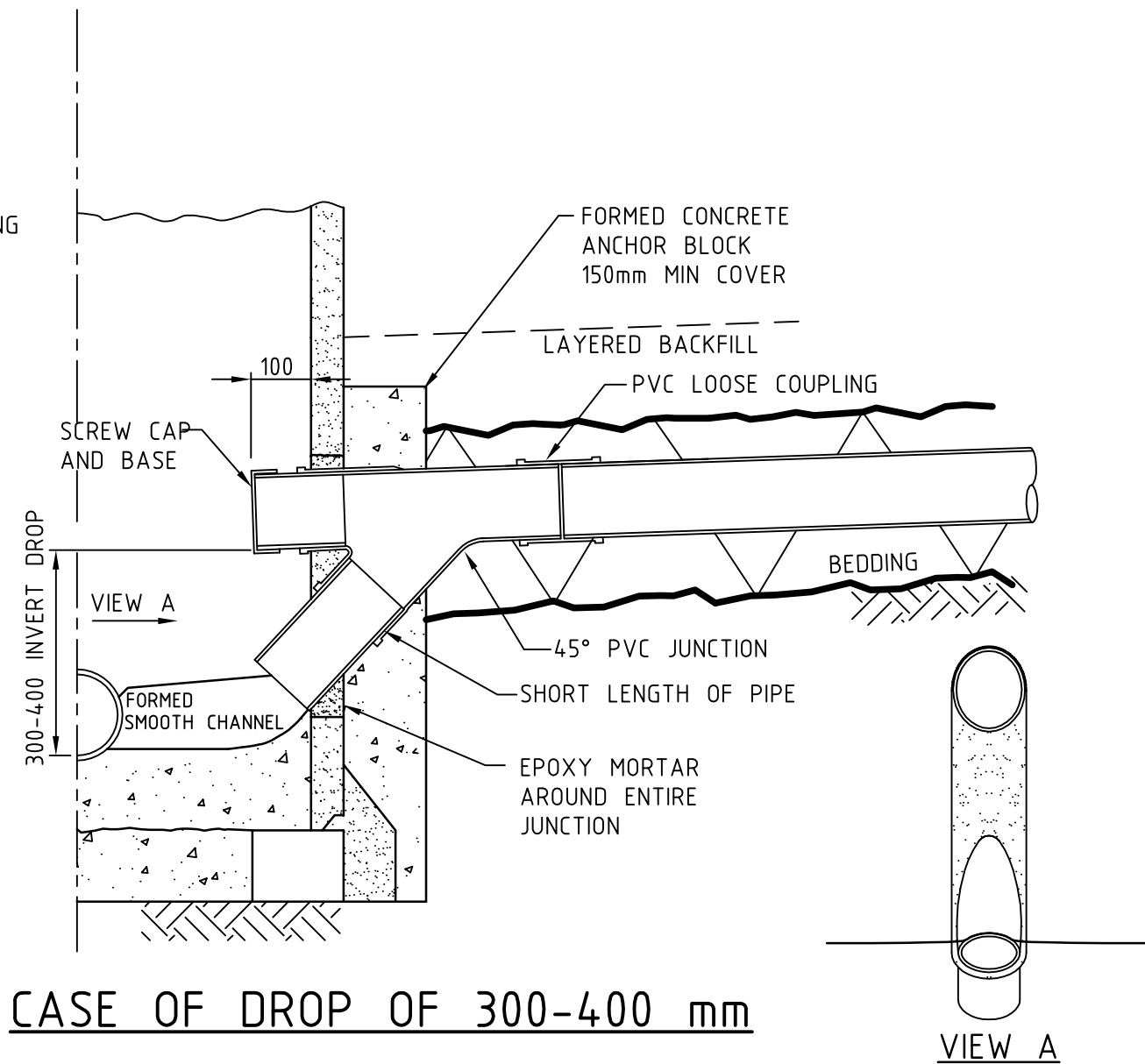

CASE OF DROP OF 300-400 mm

DROP MANHOLE DETAIL PVC 150 ϕ
 (FOR DROPS MORE THAN 600mm SEE 21/204 SHEET 1)

| | | |
|------------------------------------|---|--|
| NELSON CITY COUNCIL | SEWER DROP MANHOLE DETAILS | |
| | INFRASTRUCTURE DIVISION APPROVED MANAGER INFRASTRUCTURAL ASSETS DATE | PLAN No. 21/204 SHEET 2 |

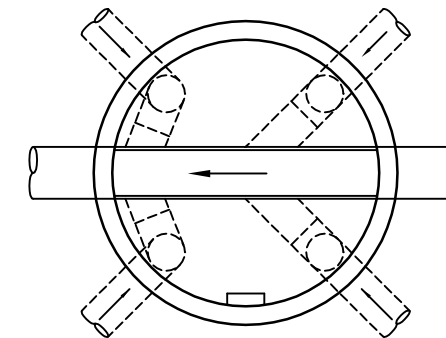
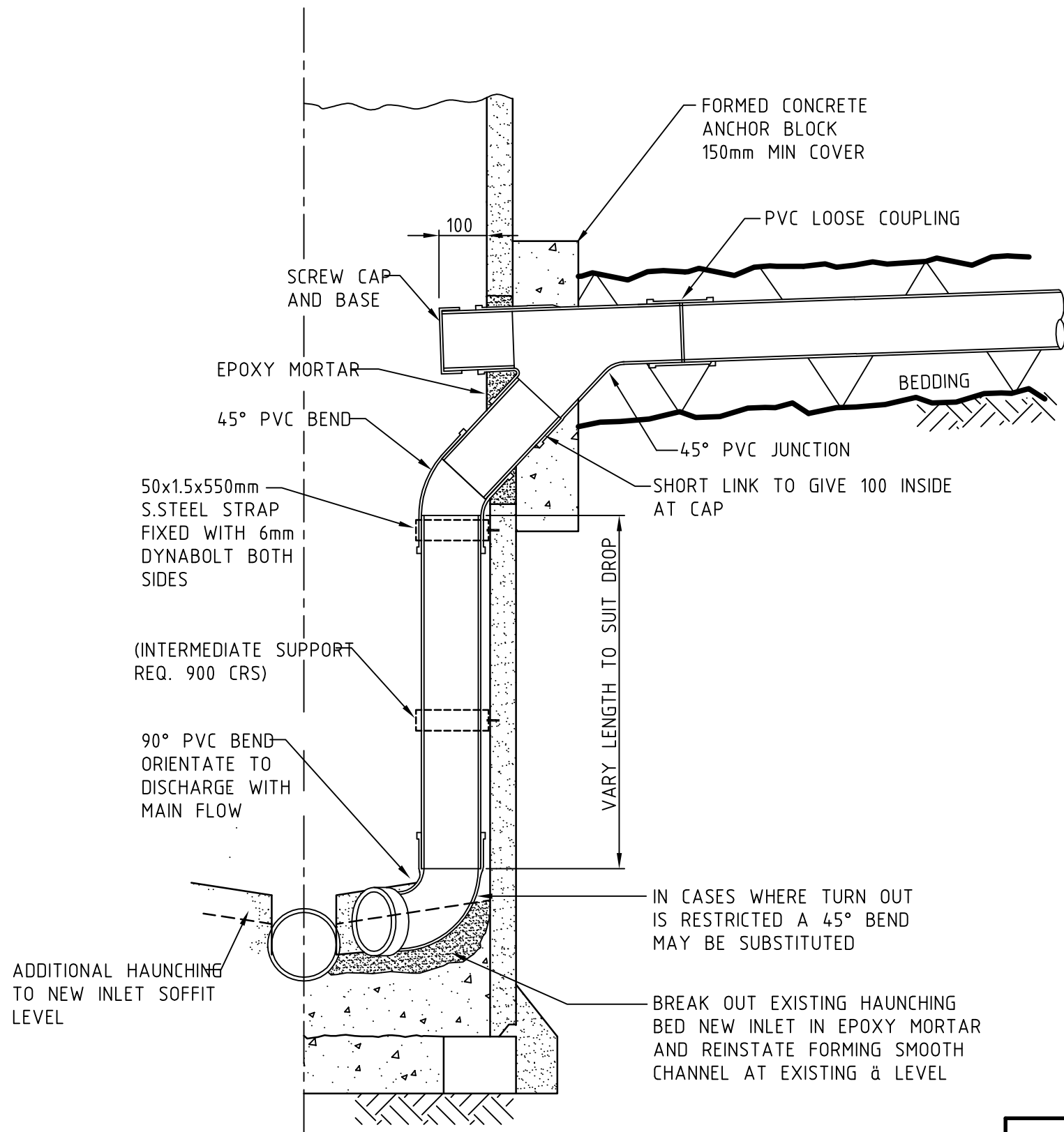

GENERAL APPROACH POSITION RELATED TO MANHOLE -1 ONLY

INTERNAL DROP MANHOLE DETAIL PVC 150 Ø

TO BE USED IN SPECIAL CASES AT ENGINEERS DIRECTION FOR EXISTING MANHOLES ONLY

| | | |
|----------------------------|--|--------------------------------------|
| NELSON CITY COUNCIL | INTERNAL DROP MANHOLE | |
| | INFRASTRUCTURE DIVISION APPROVED, MANAGER INFRASTRUCTURAL ASSETS DATE | PLAN No. 21/204 SHEET 3 |

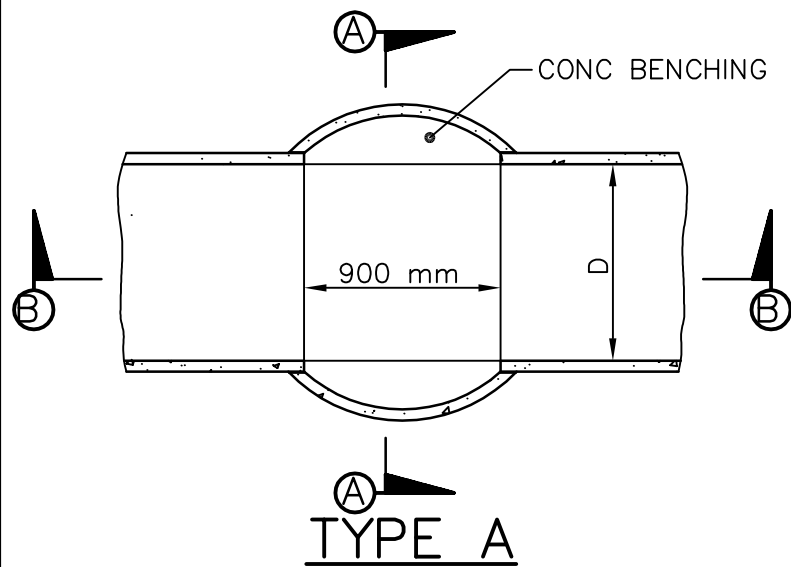

TYPE A

THROUGH CHANNEL ONE PIPE DIA.

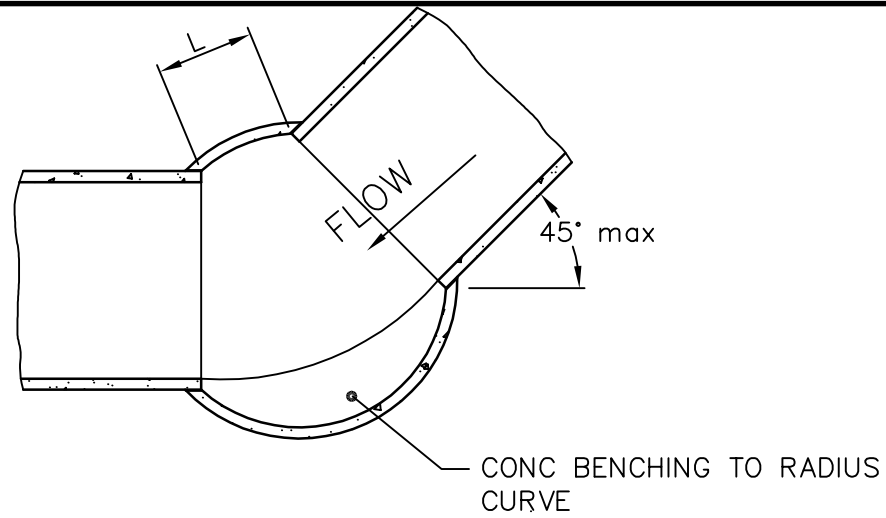

TYPE B

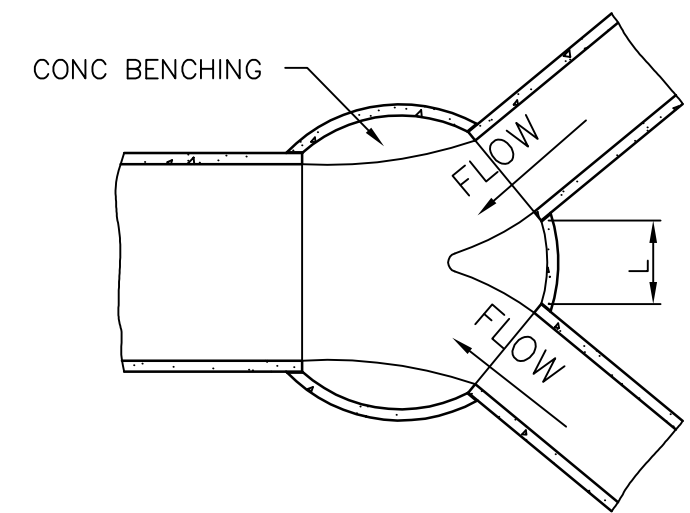

TYPE C

TYPICAL JUNCTION MANHOLE.

NOTES

1. FOR PIPES OVER 1050 DIA, MANHOLES ARE TO BE A SPECIFIC DESIGN.

2. TABLE OF DIMENSIONS

| M.H(DIA) | L (MIN) | T (MIN) | D (MAX) |
|----------|---------|---------|---------|
| 1500 | 500 | 200 | 1050 |
| 1350 | 400 | 200 | 750 |
| 1050 | 350 | 150 | 450 |

3. PRECAST CONCRETE MANHOLE RISERS SHALL COMPLY WITH THE REQUIREMENTS FOR CLASS 2 PRECAST CONCRETE PIPES TO AS/NZS 4058.

4. FOR MANHOLE FINISHING OFF DETAILS E.G. HAUNCHING, SEALING etc SEE NCC STANDARD DRAWING 21/204 SHEET 1

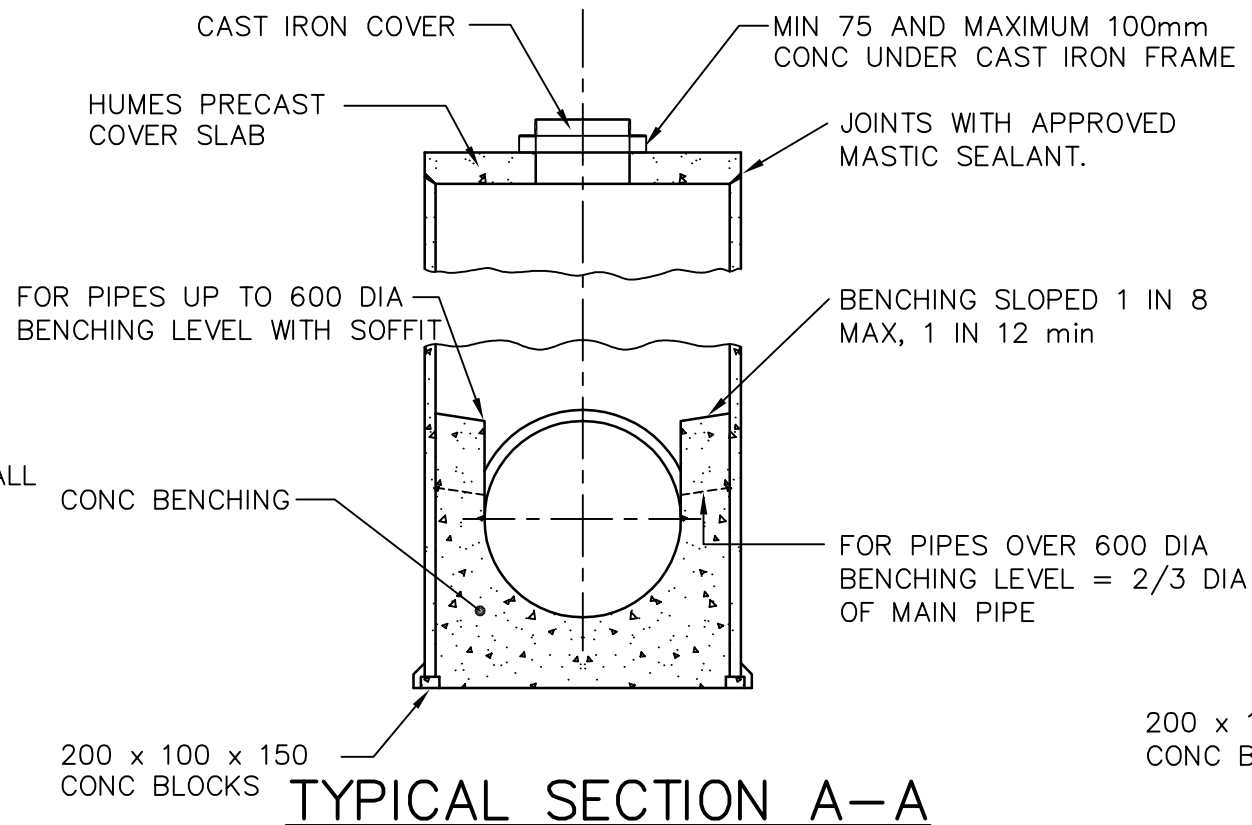

TYPICAL SECTION A-A

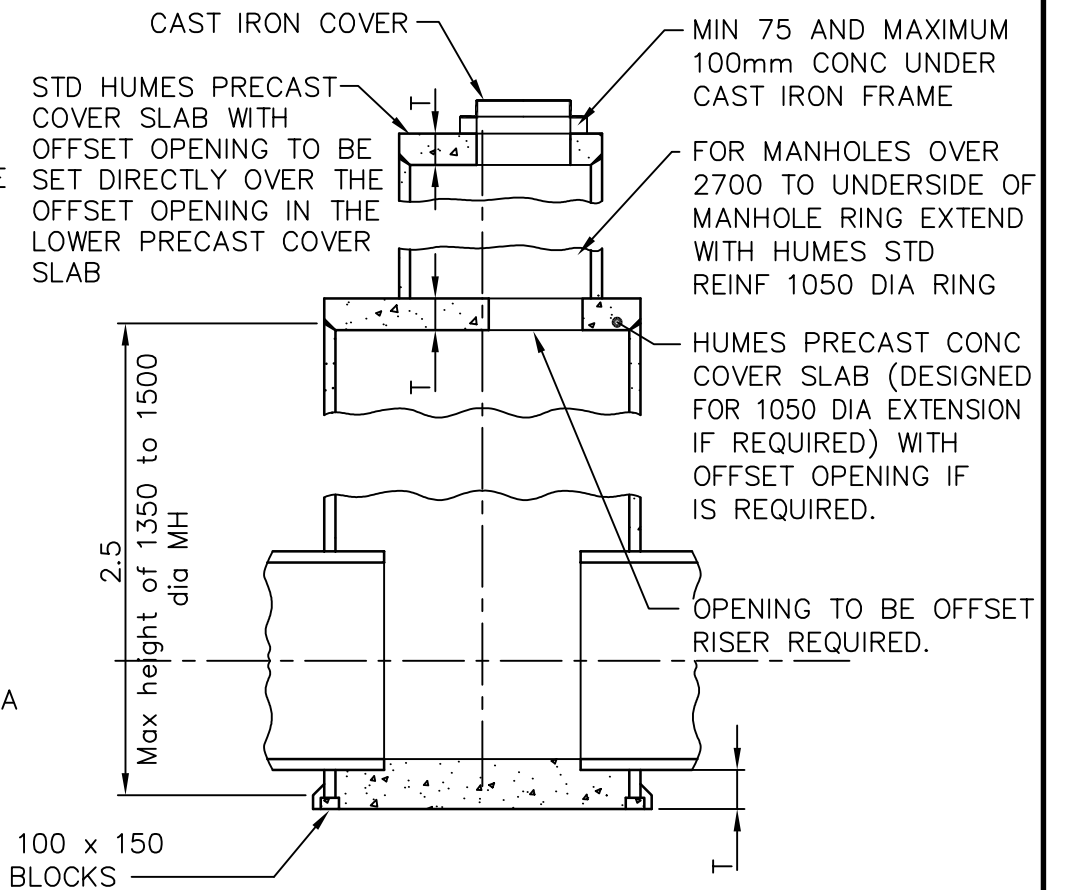

TYPICAL SECTION B-B

**NELSON
CITY
COUNCIL**

**STANDARD STORMWATER MANHOLE
DETAILS**

INFRASTRUCTURE DIVISION

APPROVED

MANAGER INFRASTRUCTURAL ASSETS DATE

PLAN No.

21/204

SHEET 4

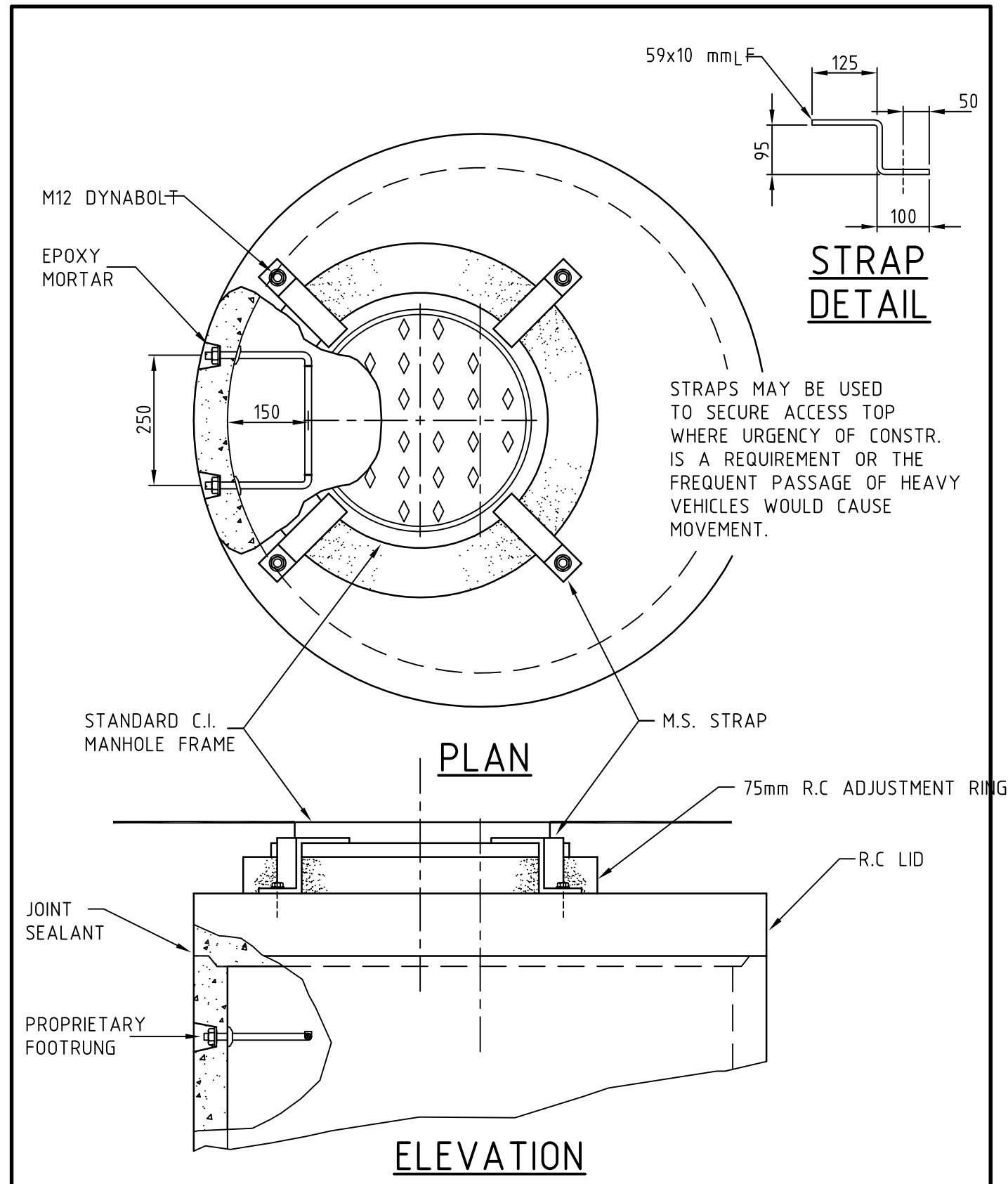

**NELSON
CITY
COUNCIL**

**MISCELLANEOUS MANHOLE DETAILS
(ACCESS FRAME CLIPS)**

INFRASTRUCTURE DIVISION

PLAN No.

APPROVED

21/204

.....
MANAGER INFRASTRUCTURAL ASSETS

DATE

SHEET 5

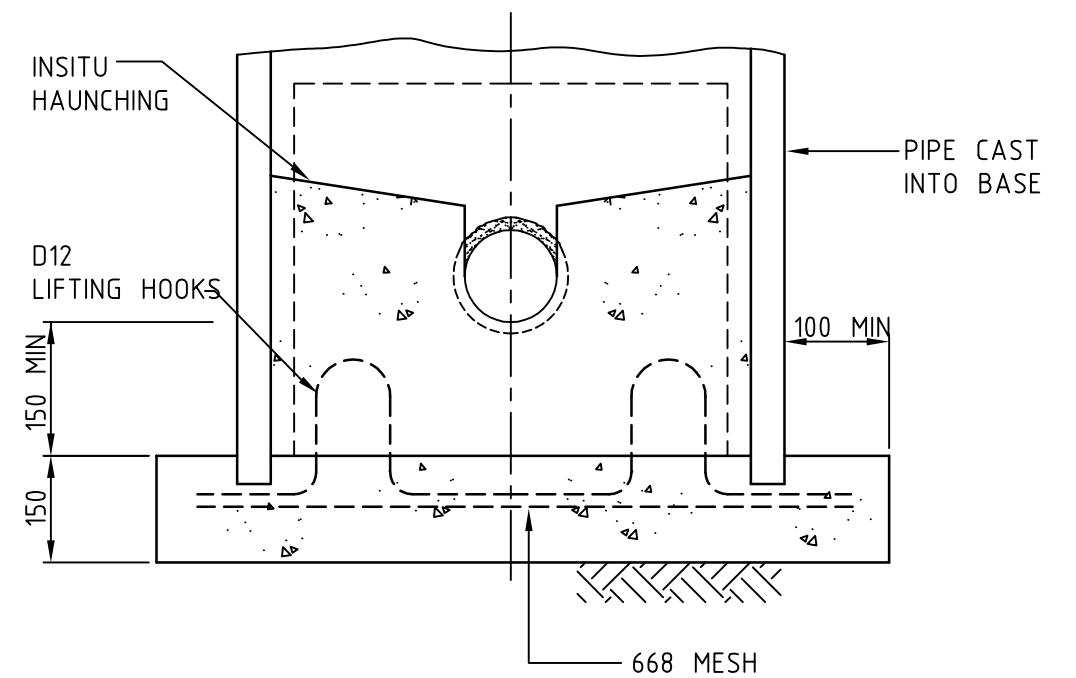
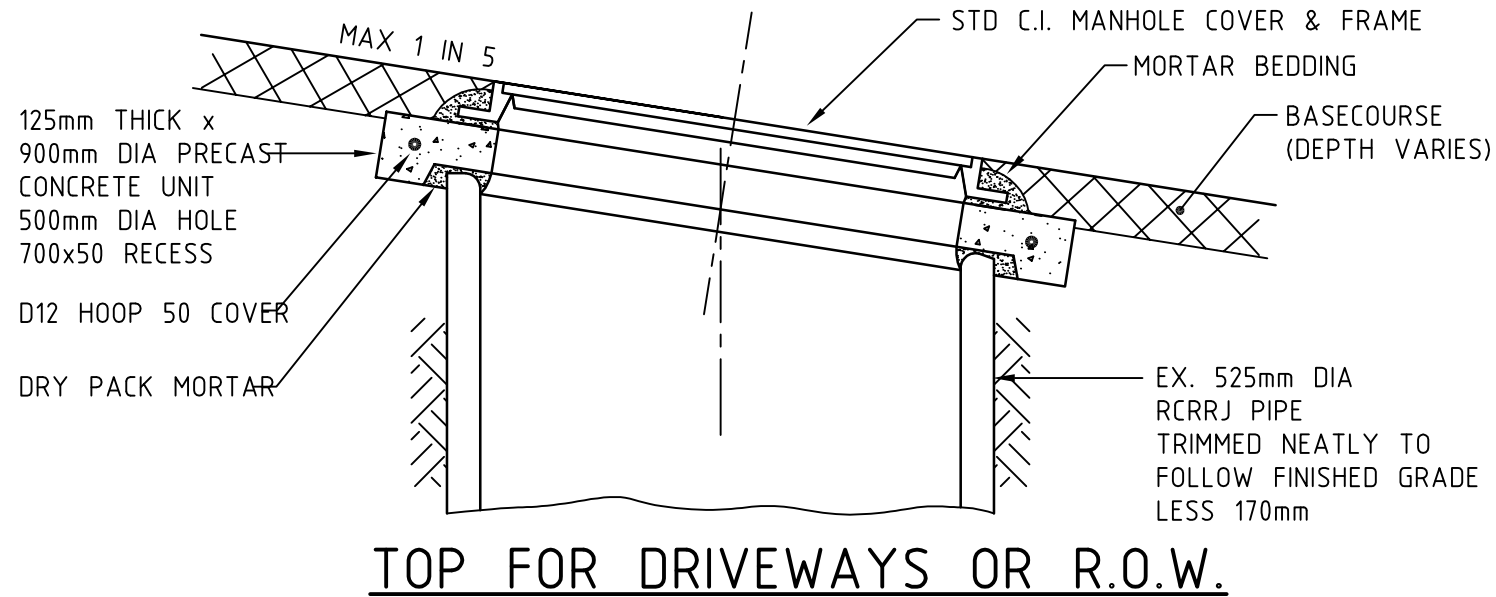

ALTERNATIVE PRECAST UNIT

NOTES

1. APPROVED PRE-FORMED PLASTIC INSPECTION CHAMBERS MAY BE USED AS MINI-MANHOLES FOR PIPE SIZES 100mm DIA & 150mm DIA SUITABLE FOR SEWER & STORMWATER SEWERS.
2. MINI-MANHOLES ARE NOT TO BE ASSUMED TO REPLACE THE STANDARD MANHOLE.
3. MINI-MANHOLES SHALL NOT BE USED IN AREAS SUBJECT TO VEHICULAR TRAFFIC, EXCEPT IN FORMED RESIDENTIAL DRIVEWAYS OR RIGHTS OF WAYS FOR LIGHT DOMESTIC VEHICLES.
4. THE USE OF MINI-MANHOLES IS TO BE LIMITED, AND AT THE DISCRETION OF COUNCIL:
 - A) MANHOLES LESS THAN 1M DEEP.
 - B) THE MAXIMUM PIPE SIZES OF 150mm DIA FOR SEWERS & 225mm DIA FOR STORMWATER DRAINS.
 - C) MANHOLES AT THE HEAD OF A LINE.
 - D) STRAIGHT THROUGH MANHOLES.
 - E) CHANGES OF GRADE.
5. CONCRETE MINI-MANHOLES AS DETAILED ARE NOT TO BE USED IN SEWERS AT:
 - A) JUNCTIONS
 - B) DEFLECTIONS GREATER THAN 45 DEGREES.

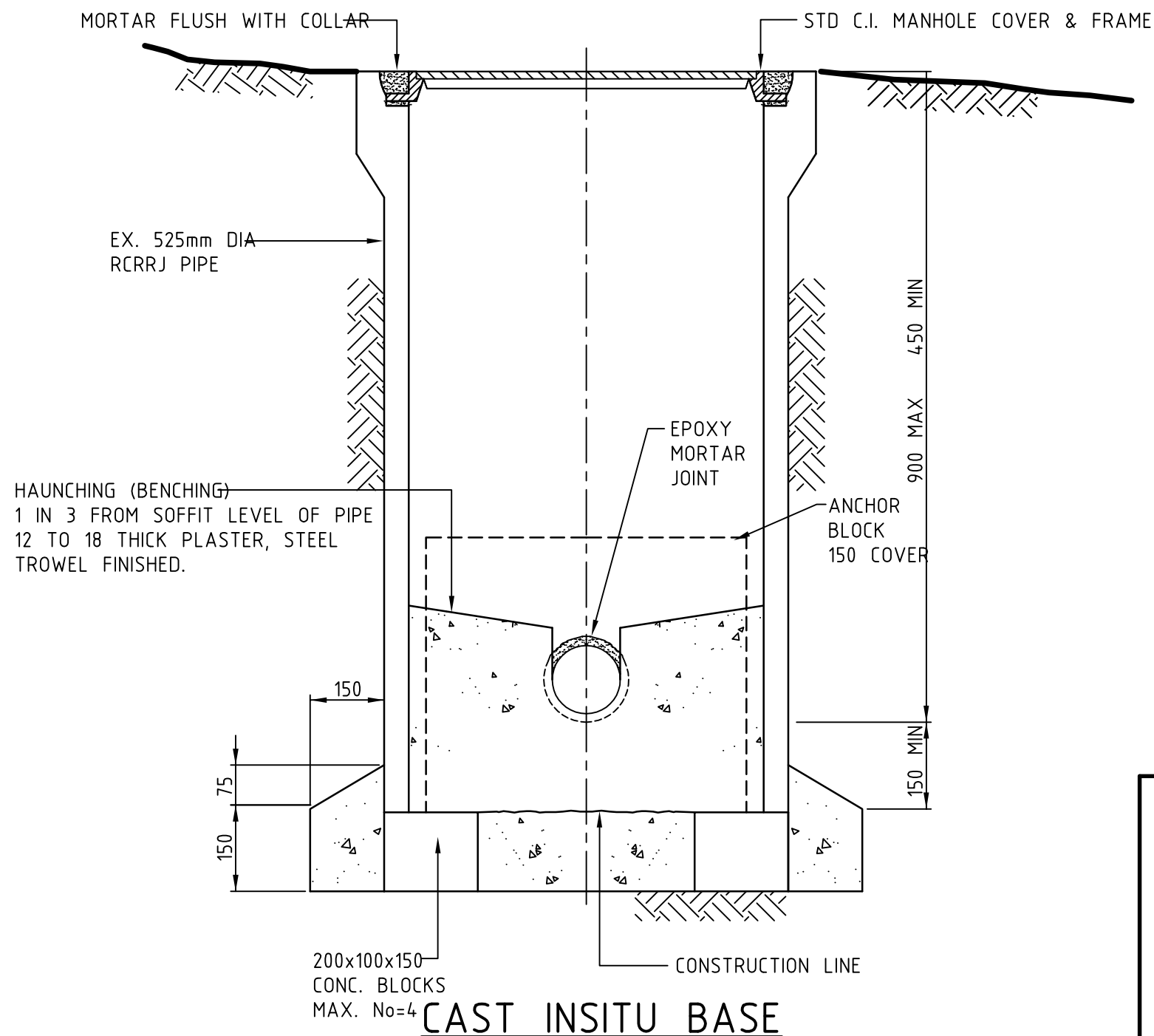

| | | |
|------------------------------------|--|--|
| NELSON CITY COUNCIL | SHALLOW MINI-MANHOLES | |
| | INFRASTRUCTURE DIVISION APPROVED MANAGER INFRASTRUCTURAL ASSETS DATE | PLAN No. 21/204 SHEET 6 |

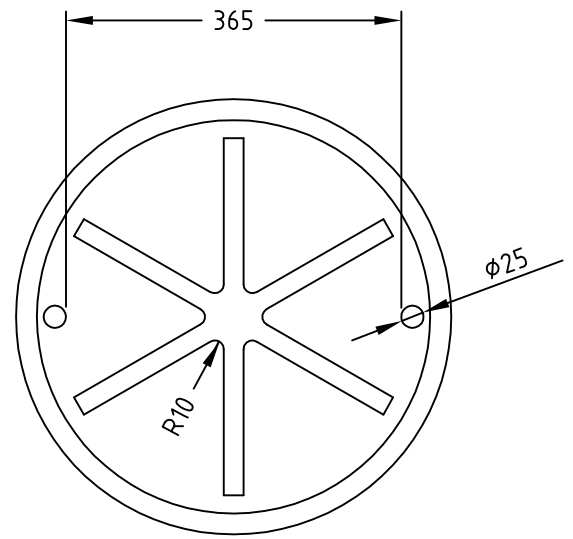
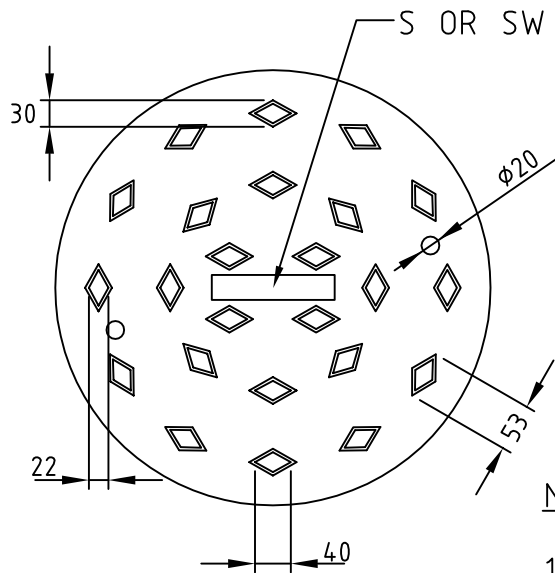

NOTE

1. TO BE USED FOR MINI-MANHOLES & TRAFFIC LOADED LHCE's
1. MATERIAL GREY IRON
2. ALL DIMENSIONS ARE IN mm
3. FRAME WEIGHT : 27KGS
4. COVER WEIGHT : 33KGS

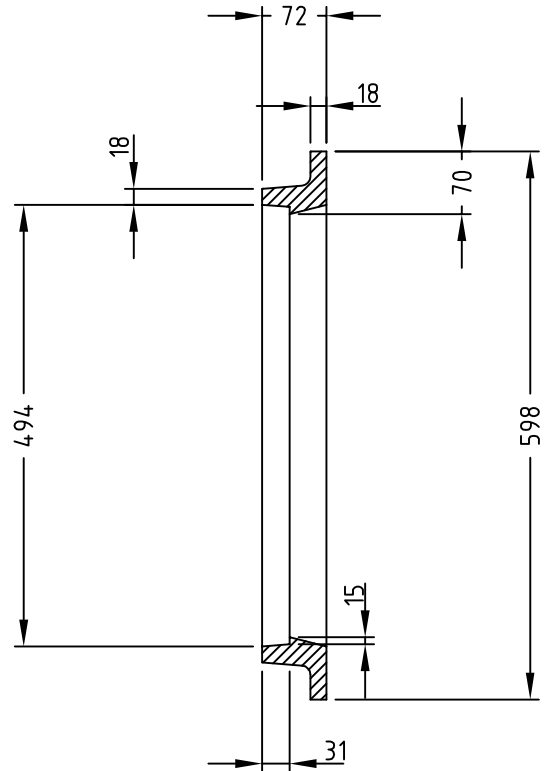
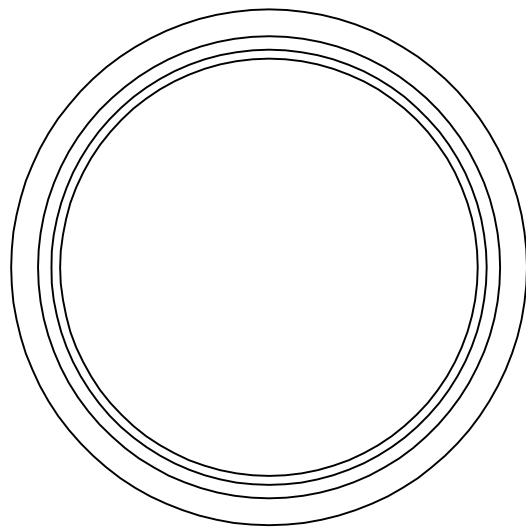
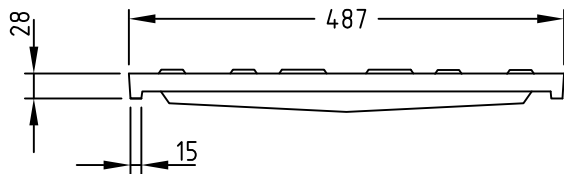

**NELSON
CITY
COUNCIL**

**STANDARD 450mm ϕ (NOMINAL)
FRAME AND COVER**

INFRASTRUCTURE DIVISION

PLAN No.

APPROVED

21/204

.....
MANAGER INFRASTRUCTURAL ASSETS DATE

SHEET 7

NOTE

1. TO BE USED ON ALL STANDARD 1050 ϕ MANHOLES OR LARGER
2. MATERIAL GREY IRON
3. ALL DIMENSIONS ARE IN mm
4. FRAME WEIGHT : 48KGS
5. COVER WEIGHT : 62KGS

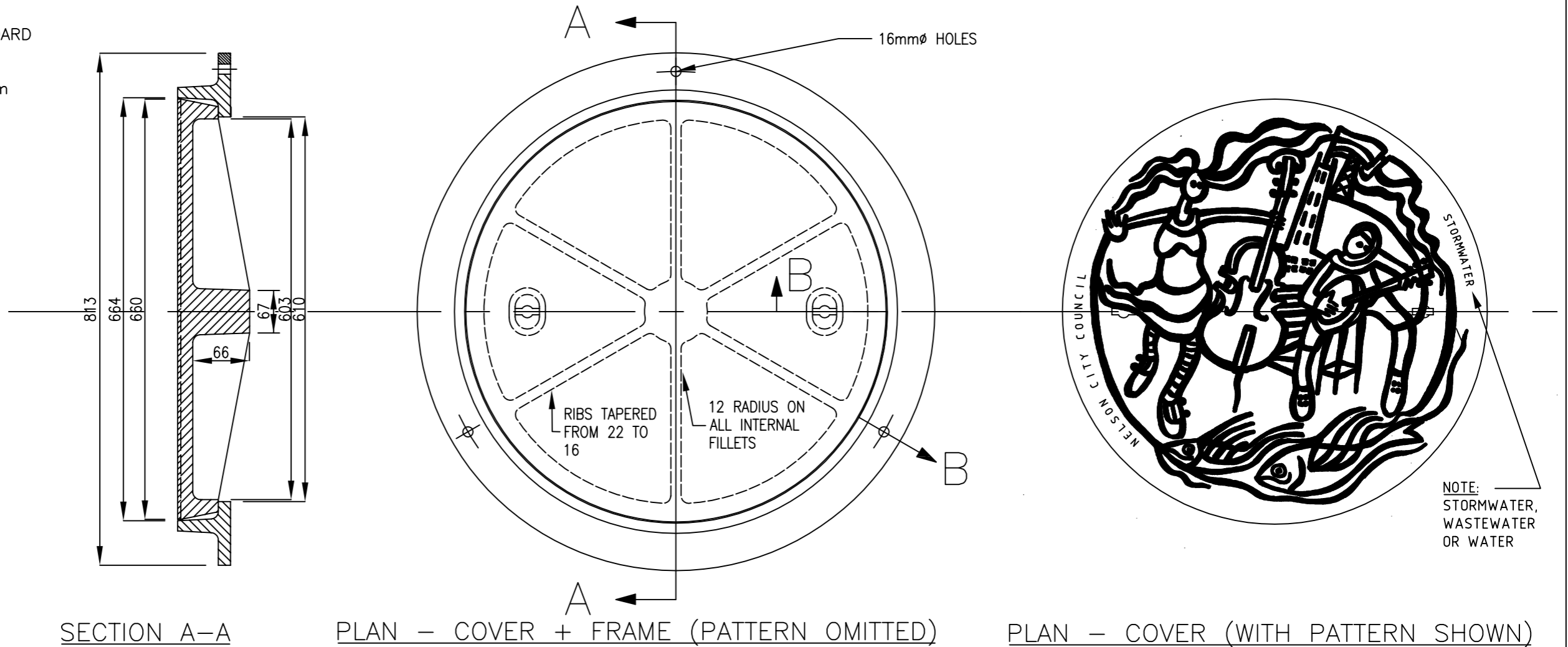

SECTION A-A

PLAN - COVER + FRAME (PATTERN OMITTED)

PLAN - COVER (WITH PATTERN SHOWN)

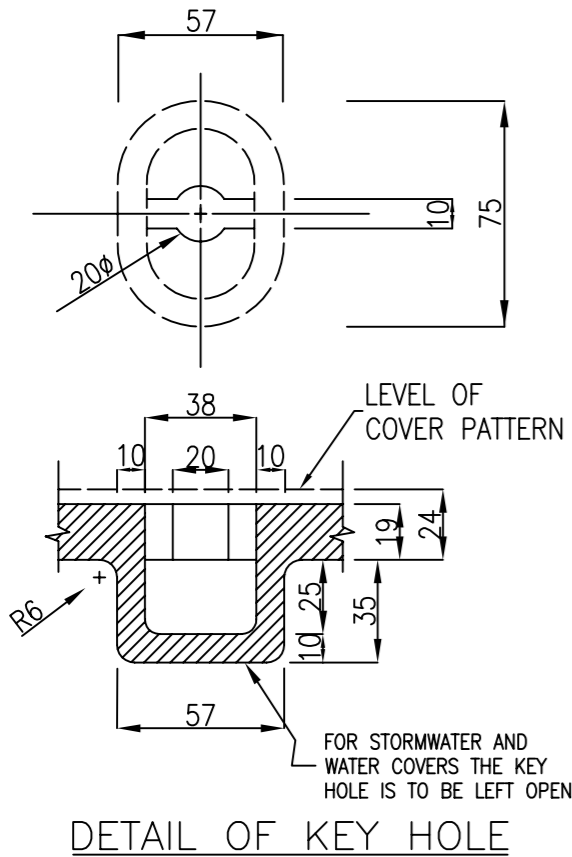

DETAIL OF KEY HOLE

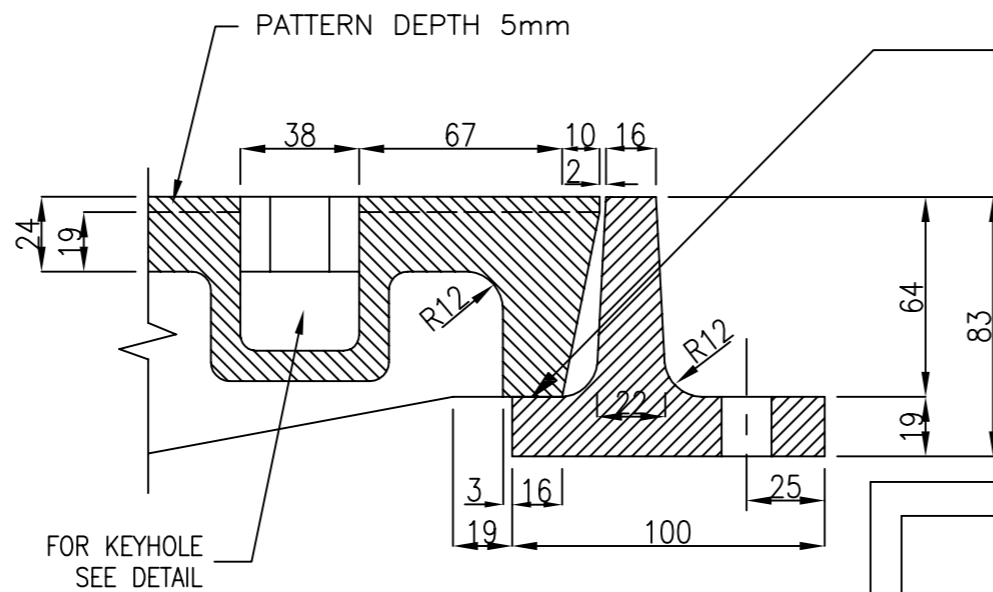

SECTION B-B

SEATS OF CENTRE AND FRAME TO BE FINISHED BY MACHINING OR OTHERWISE, SO THAT THE CENTRE SEATS EVENLY AND COMPLETELY OVER THE FULL CIRCUMFERENCE IN ANY POSITION IN THE FRAME. FINISHED THICKNESS OF THE FRAME SEAT TO BE NOT LESS THAN 17mm AFTER ANY MACHINING.

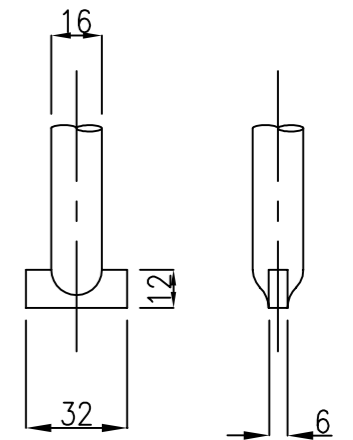

DETAILS OF LIFTING KEY

NELSON CITY COUNCIL

STANDARD 600mm ϕ (NOMINAL)
C.I. FRAME AND COVER

ASSET MANAGEMENT DIVISION

APPROVED

MANAGER INFRASTRUCTURAL ASSETS DATE

04/07/2005

PLAN No.

21/204

SHEET 8

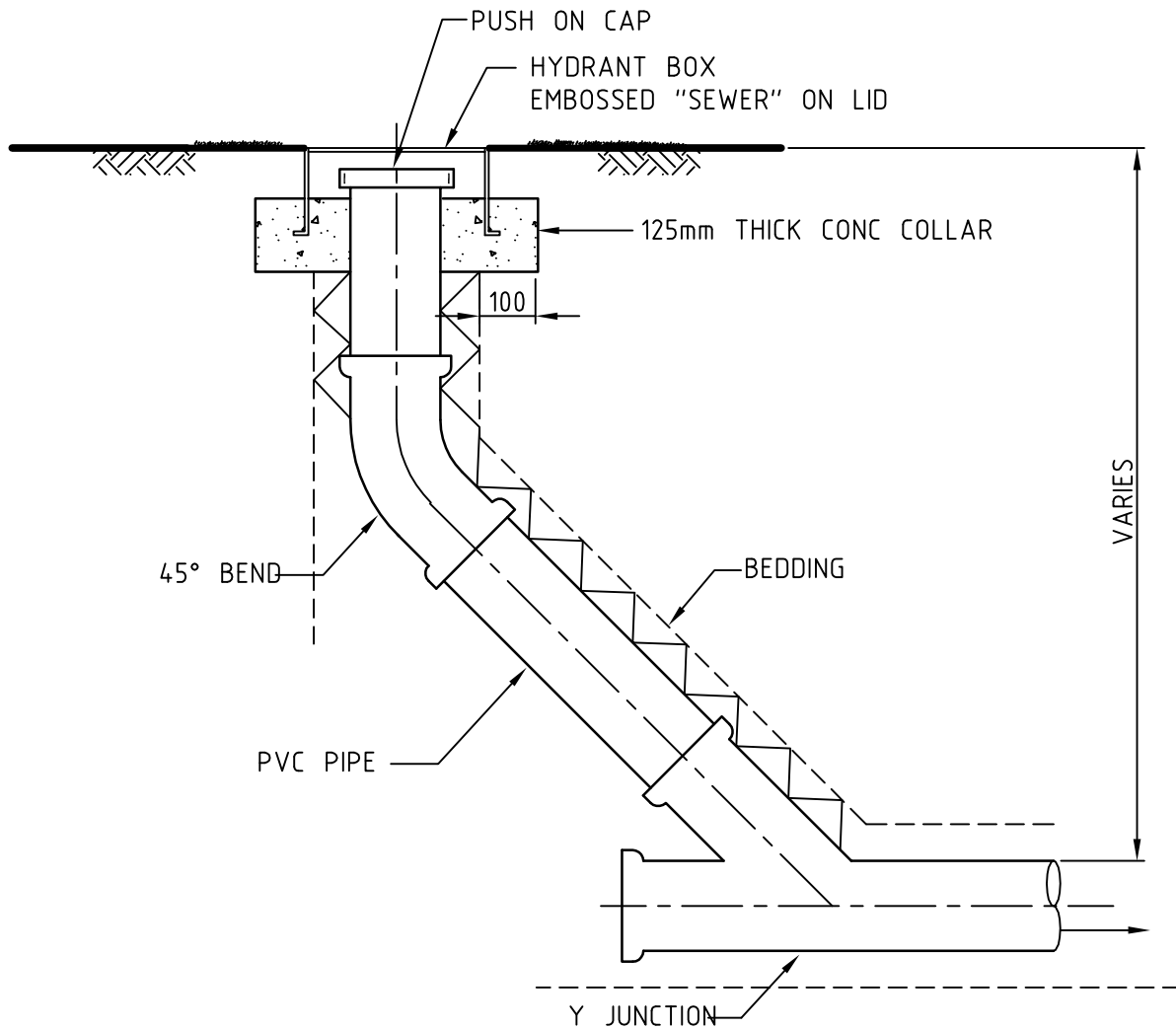

NOT FOR USE WITHIN ROAD RESERVE, RIGHT OF WAY OR ANY AREA SUBJECT TO VEHICULAR TRAFFIC. FOR TRAFFIC LOADED LHCE REFER TO STANDARD DRAWING 21/205 SHEET 2.

NOTES

1. LAMP HOLE CLEANING EYES (LHCE), MAY BE USED IN LIEU OF MANHOLES IN ANY OR ALL OF THE FOLLOWING CIRCUMSTANCES
 - A) GENERALLY LHCE ARE FOR USE ON PRIVATE PROPERTY ONLY
 - B) ONLY ONE LHCE SHALL BE PERMITTED BETWEEN MANHOLES
 - C) LHCE MAY BE USED AT THE HEAD OF A DRAINAGE RUN
 - D) LHCE MAY BE USED WHERE ACCESS POINTS ARE REQUIRED AT INTERVALS OF LESS THAN 50 METERS
 - E) LHCE MAY BE USED AT THE TOP OF STEEP BANKS WHERE THE USE OF A STANDARD MANHOLE WOULD BE IMPRACTICAL
2. LHCE WILL NOT BE APPROVED FOR USE, WITHIN ROAD CARRIAGEWAYS, FOOTPATHS OR BERMS

| | | |
|---|--|---------------|
| NELSON CITY COUNCIL | LAMP HOLE CLEANING EYE (NON TRAFFIC LOADED) | |
| | INFRASTRUCTURE DIVISION | PLAN No. |
| APPROVED | DATE | 21/205 |
| MANAGER INFRASTRUCTURAL ASSETS | DATE | SHEET 1 |

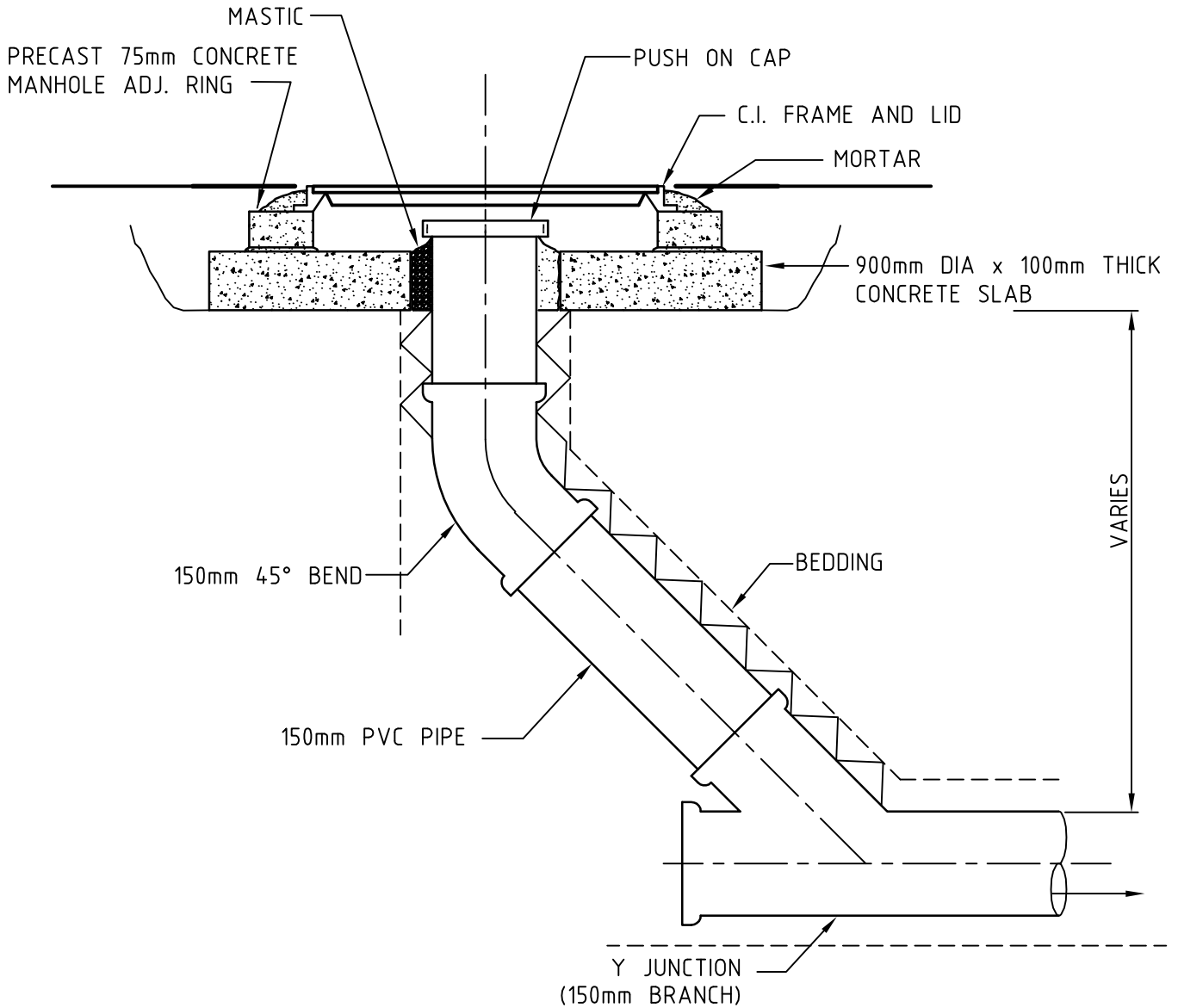

NOTES

1. LAMP HOLE CLEANING EYES (LHCE), MAY BE USED IN LIEU OF MANHOLES IN ANY OR ALL OF THE FOLLOWING CIRCUMSTANCES...
 - A) GENERALLY LHCE ARE FOR USE ON PRIVATE PROPERTY ONLY
 - B) ONLY ONE LHCE SHALL BE PERMITTED BETWEEN MANHOLES
 - C) LHCE MAY BE USED AT THE HEAD OF A DRAINAGE RUN
 - D) LHCE MAY BE USED WHERE ACCESS POINTS ARE REQUIRED AT INTERVALS OF LESS THAN 50m
 - E) LHCE MAY BE USED AT THE TOP OF STEEP BANKS WHERE THE USE OF A STANDARD MANHOLE WOULD BE IMPRACTICAL
2. LHCE WILL NOT BE APPROVED FOR USE, WITHIN ROAD CARRIAGEWAYS, FOOTPATHS OR BERMS

| | | |
|---|--|---------------|
| NELSON CITY COUNCIL | LAMP HOLE CLEANING EYE (TRAFFIC LOADED) | |
| | INFRASTRUCTURE DIVISION | PLAN No. |
| APPROVED | DATE | 21/205 |
| MANAGER INFRASTRUCTURAL ASSETS | DATE | SHEET 2 |

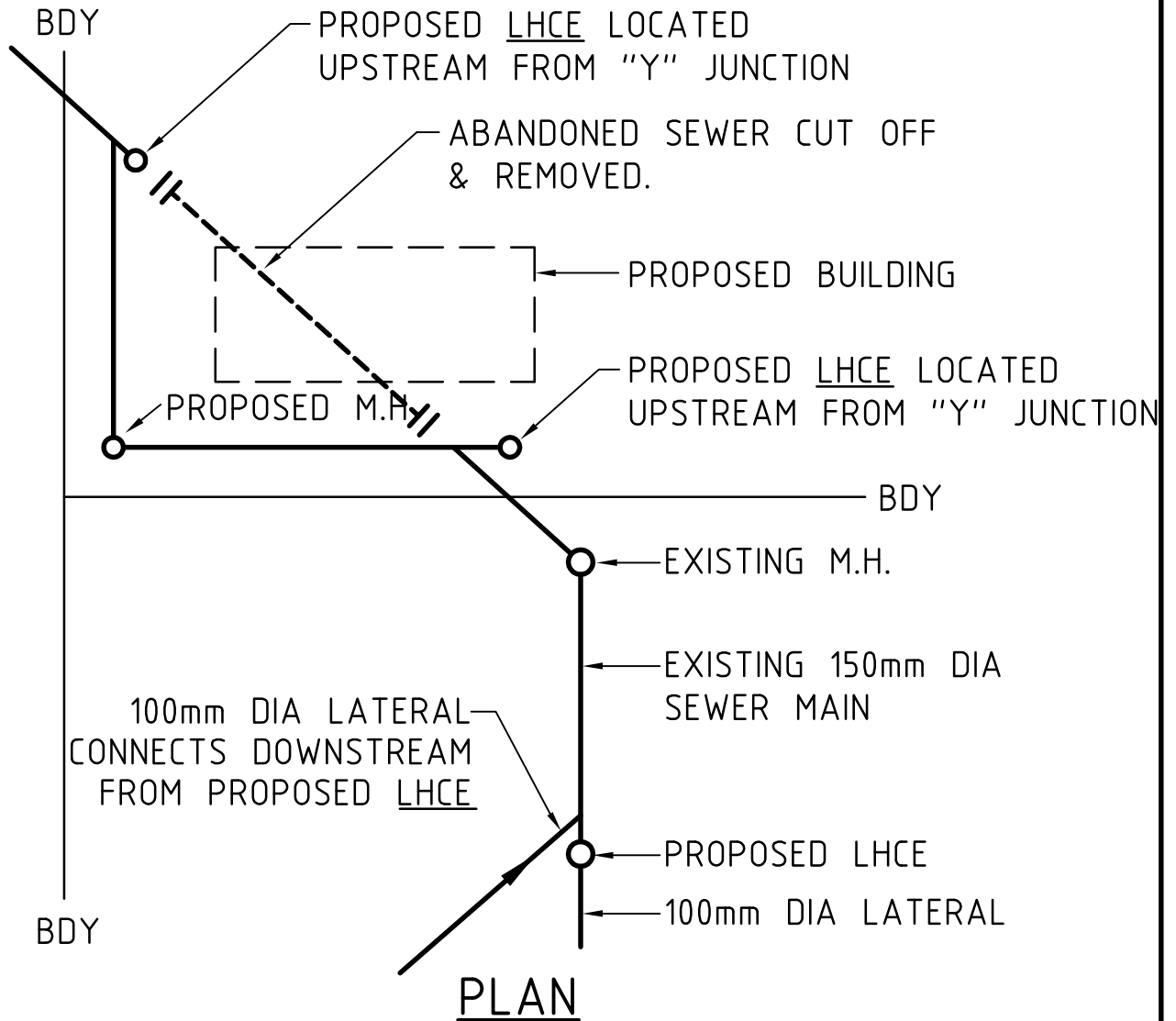
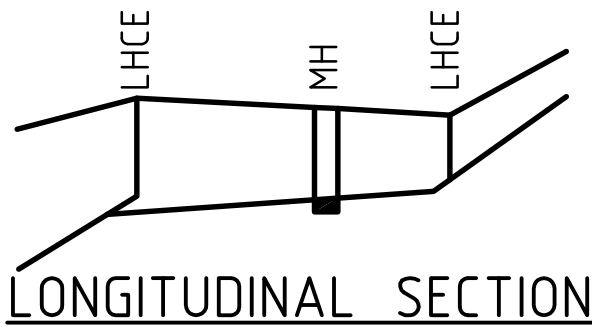

IF A CHANGE IN GRADE OR CHANGE OF DIRECTION IS REQUIRED OR A LATERAL IS CONNECTED THE "Y" JUNCTION FORMING THE BEND OR SPRING SHALL BE LOCATED DOWNSTREAM FROM THE LHMCE AND ANY BLANK END SEALED SECURELY.

| | | |
|------------------------------------|---|--|
| NELSON CITY COUNCIL | LAMPHOLE CLEANING EYE LOCATION | |
| | INFRASTRUCTURE DIVISION APPROVED | PLAN No. 21/205 SHEET 3 |
| | MANAGER INFRASTRUCTURAL ASSETS | DATE |

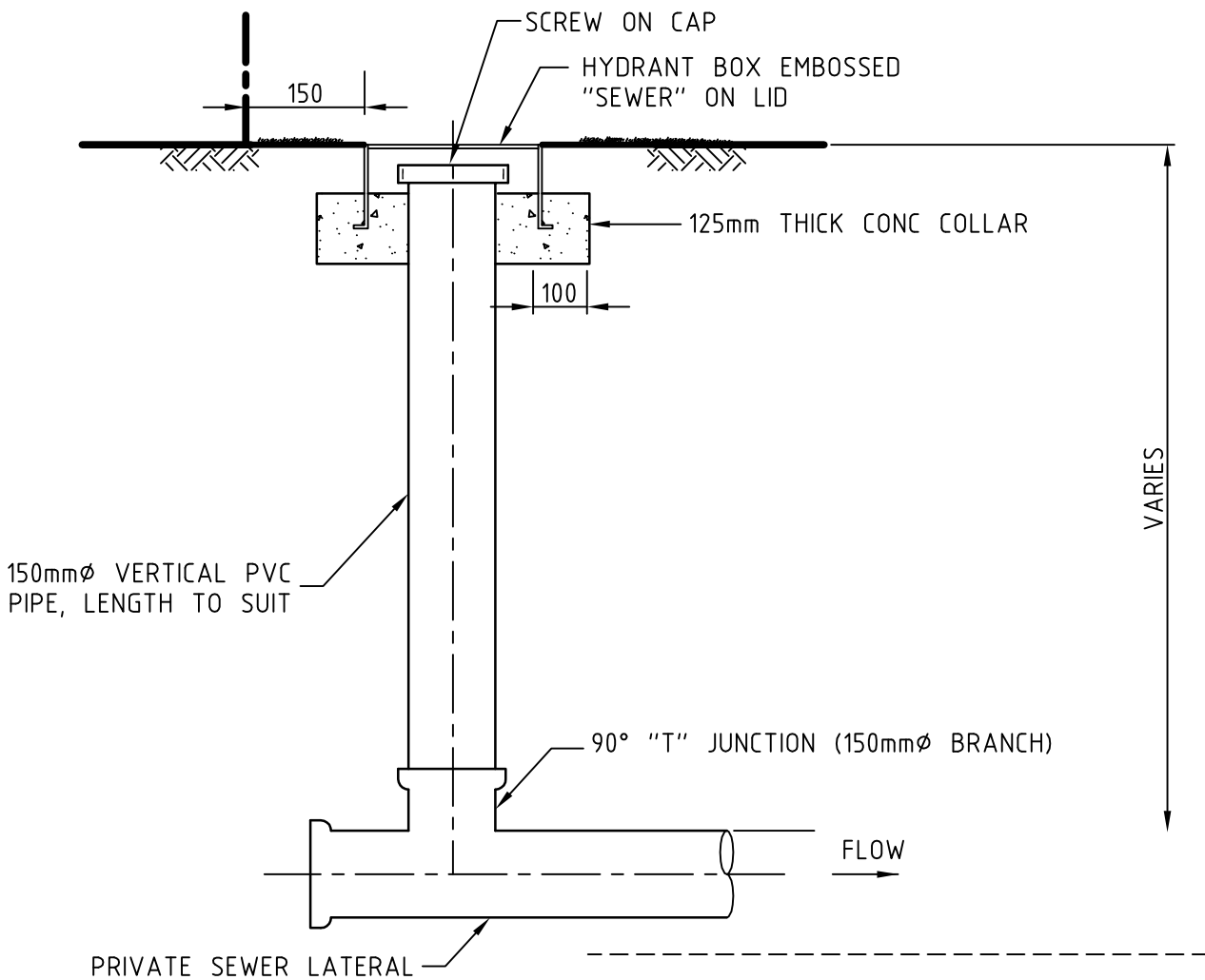

NOTES

1. IF USED IN AREA'S SUBJECT TO VEHICULAR TRAFFIC, THEN USE A TRAFFIC LOADED LID DESIGN, AS PER 21/205 SHEET 2
2. INSPECTION T'S SHALL BE POSITIONED 150mm ON THE ROAD RESERVE SIDE OF THE BOUNDARY

| | | |
|---|--------------------------------|---------------|
| NELSON CITY COUNCIL | INSPECTION TEE | |
| | INFRASTRUCTURE DIVISION | PLAN No. |
| APPROVED | DATE | 21/205 |
| MANAGER INFRASTRUCTURAL ASSETS | DATE | SHEET 4 |

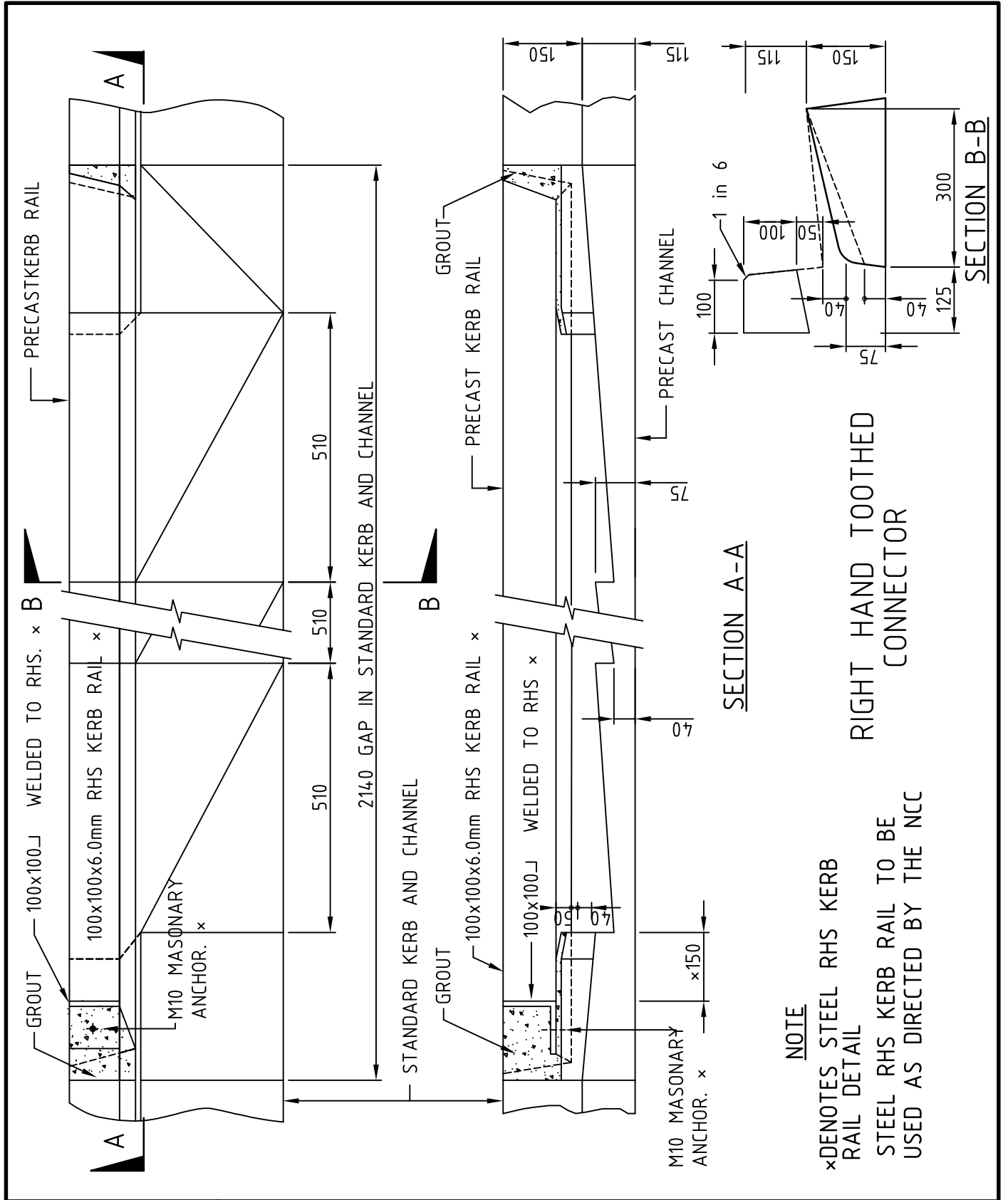

SECTION A-A

SECTION B-B

NOTE

x DENOTES STEEL RHS KERB RAIL DETAIL
 STEEL RHS KERB RAIL TO BE USED AS DIRECTED BY THE NCC

RIGHT HAND TOOTHED CONNECTOR

NELSON CITY COUNCIL

STANDARD TOOTHED CONNECTOR

INFRASTRUCTURE DIVISION

PLAN No.

APPROVED

21/206

.....
 MANAGER INFRASTRUCTURAL ASSETS DATE

SHEET 1

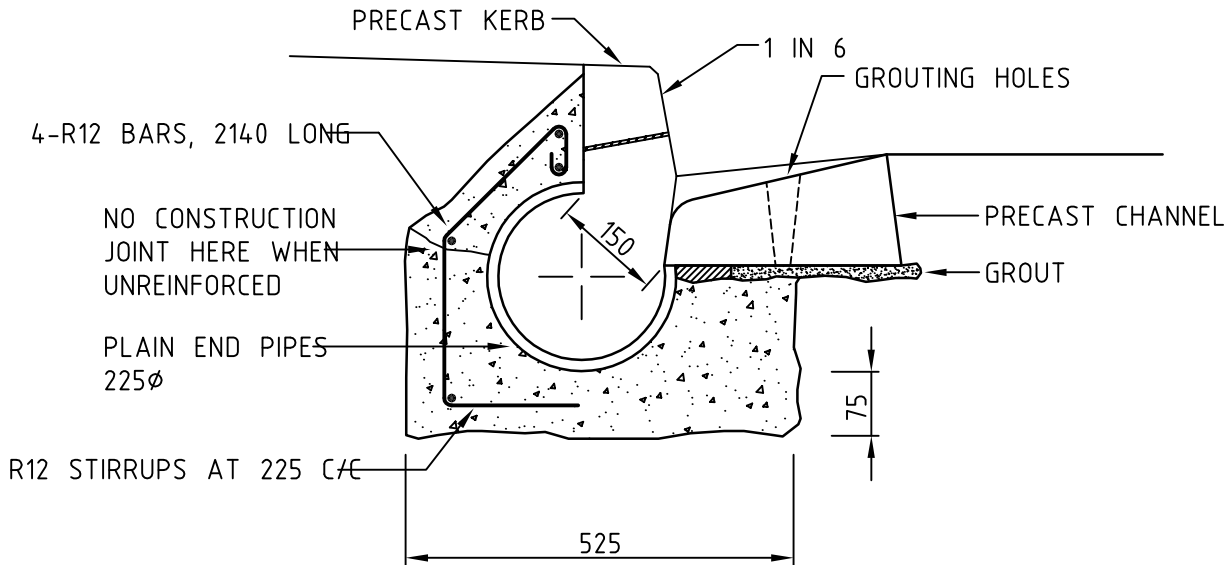

SPECIAL SHALLOW SECTION OF TOOTHED CONNECTOR

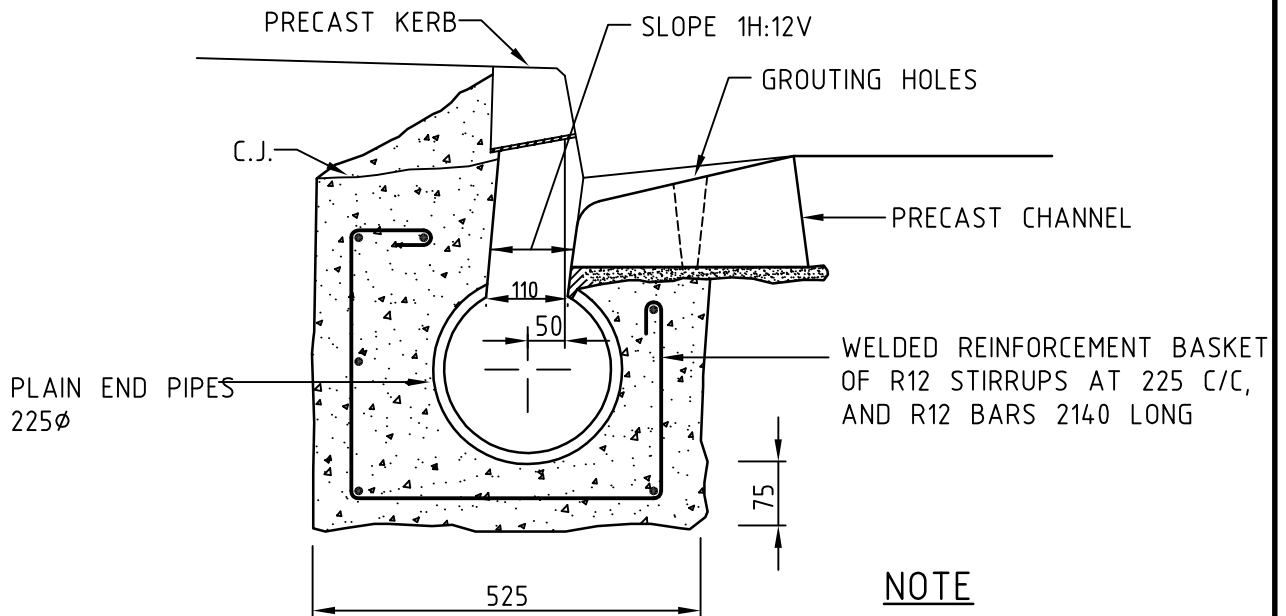

STANDARD INTAKE SECTION OF TOOTHED CONNECTOR

NOTE

REINFORCING STEEL TO BE USED WHEN REQUIRED BY THE ENGINEER

**NELSON
CITY
COUNCIL**

STANDARD INTAKE SECTION ON TOOTHED CONNECTOR

INFRASTRUCTURE DIVISION

APPROVED

.....
MANAGER INFRASTRUCTURAL ASSETS DATE

PLAN No.

21/206

SHEET 2

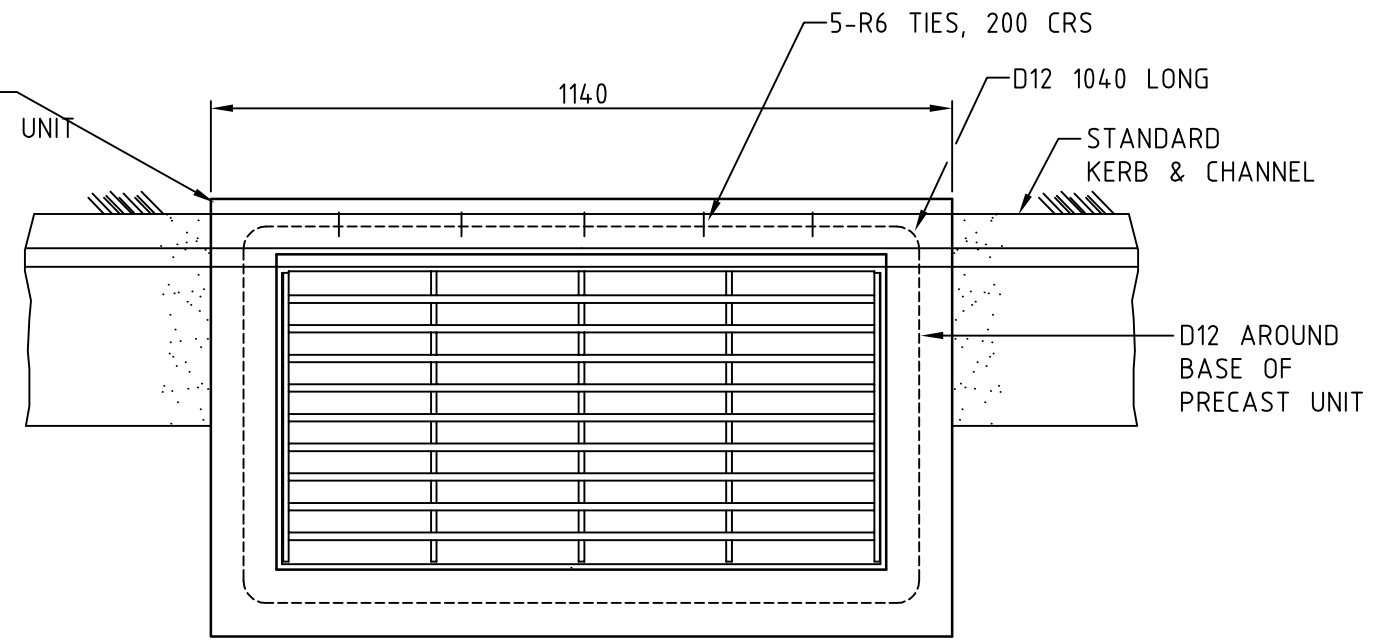
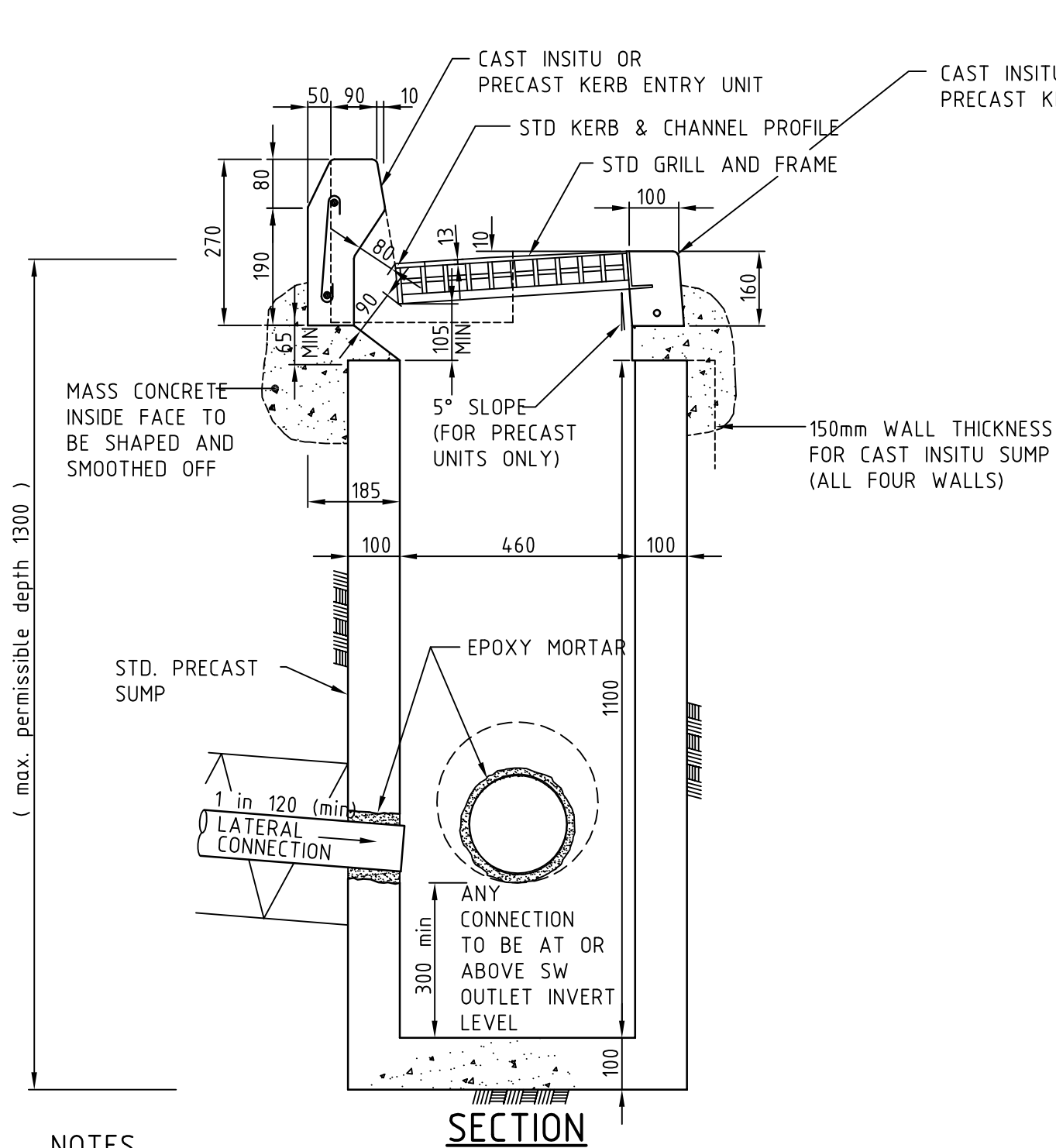

PLAN

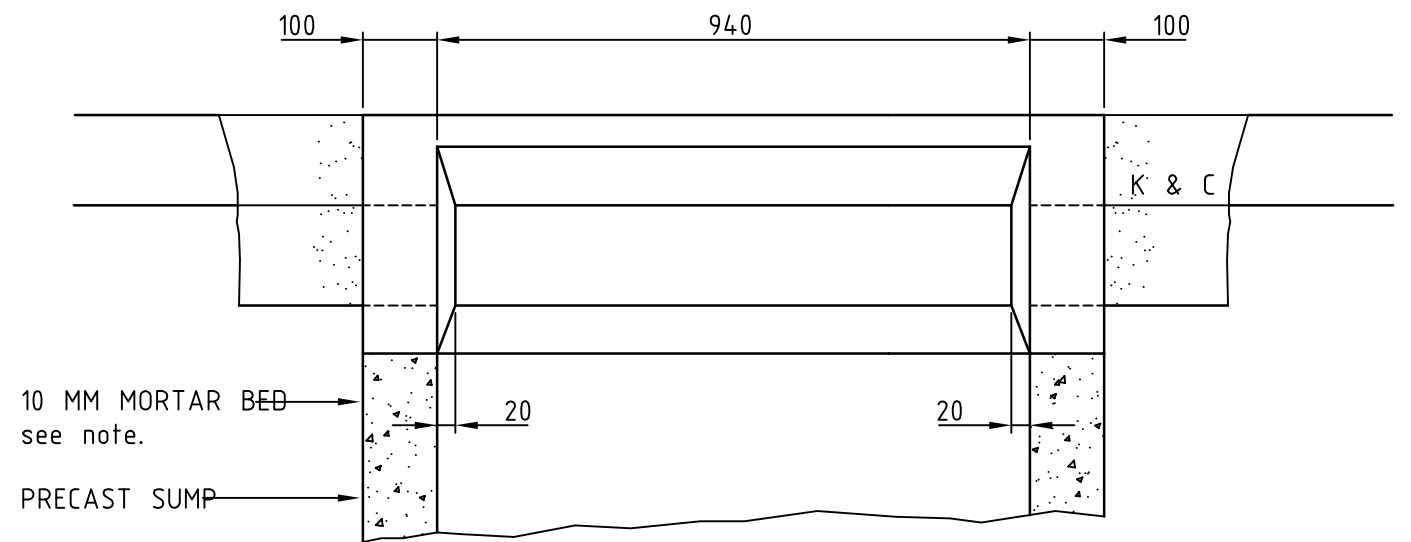

ELEVATION

GRATE AND FRAME NOT SHOWN

NOTES

- 1 SEE SHEETS 21/207 SHEET 3 FOR DETAILS OF STD GRATING AND FRAME
- 2 INSITU CONCRETE TO BE 20 MPa AFTER 28 DAYS
- 3 NO REINFORCING REQUIRED FOR CAST INSITU BACK ENTRY UNIT
- 4 WHERE SUMP IS CONCRETED TO INTERCEPT K & C AT DISTINCT GRADE THE ENTRY UNIT SHALL BE INCLINED ON THE INSITU PAD EXTENDED OVER THE SUMP WALL WIDTH

**NELSON
CITY
COUNCIL**

**STANDARD BACK ENTRY SUMP IN
STANDARD KERB & CHANNEL**

INFRASTRUCTURE DIVISION

APPROVED

MANAGER INFRASTRUCTURAL ASSETS DATE

PLAN No.

21/207

SHEET 1

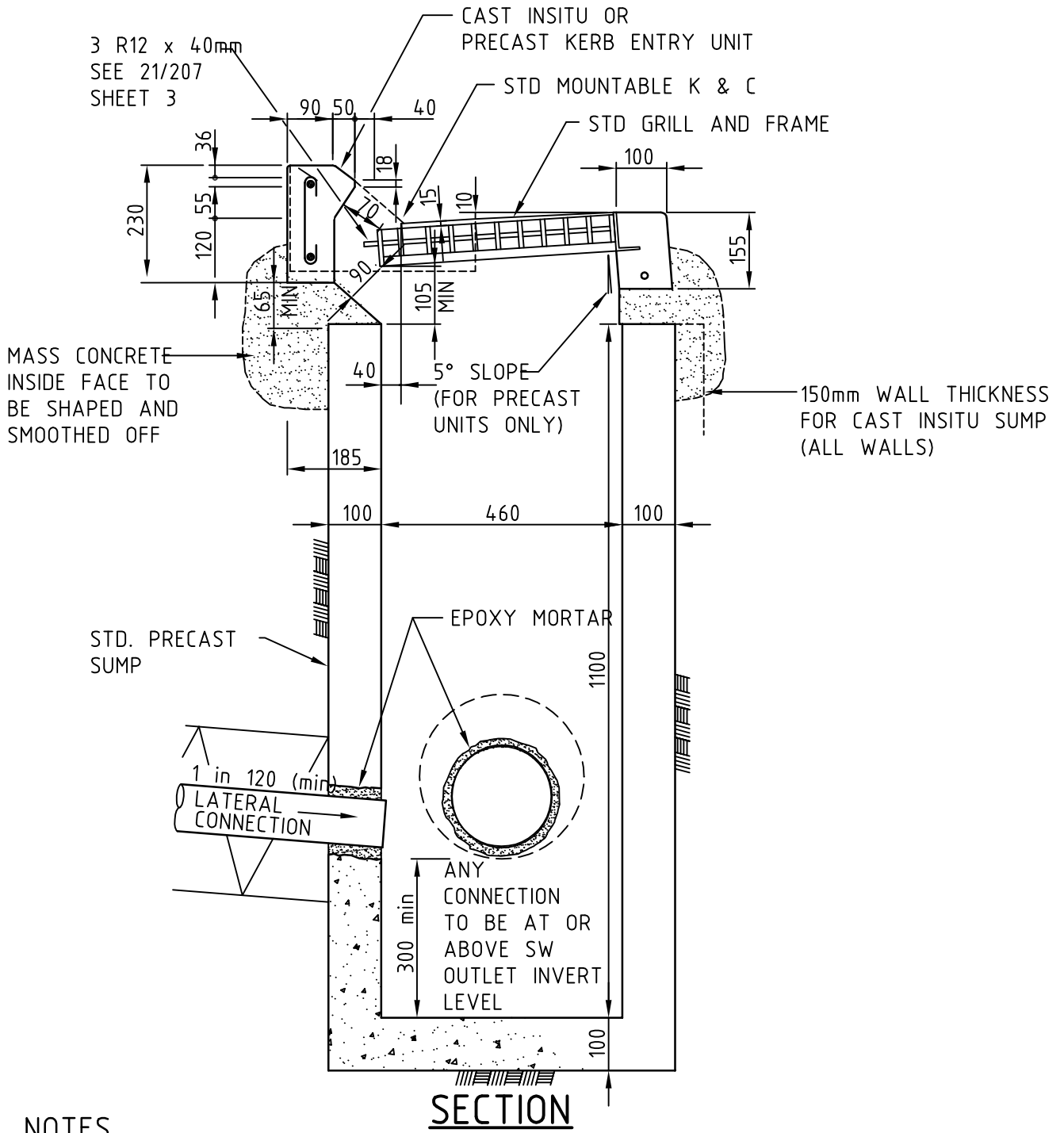

NOTES

- 1 SEE SHEETS 21/207 SHEET 3 FOR DETAILS OF STD GRATING AND FRAME
- 2 INSITU CONCRETE TO BE 20 MPa AFTER 28 DAYS
- 3 NO REINFORCING REQUIRED FOR CAST INSITU BACK ENTRY UNIT
- 4 WHERE SUMP IS CONSTRUCTED TO INTERCEPT K & C AT DISTINCT GRADE THE ENTRY UNIT SHALL BE INCLINED ON THE INSITU PAD EXTENDED OVER THE SUMP WALL WIDTH

**NELSON
CITY
COUNCIL**

**STANDARD BACK ENTRY SUMP IN
STANDARD MOUNTABLE KERB &
CHANNEL**

INFRASTRUCTURE DIVISION

APPROVED

.....
MANAGER INFRASTRUCTURAL ASSETS

DATE

PLAN No.

21/207

SHEET 2

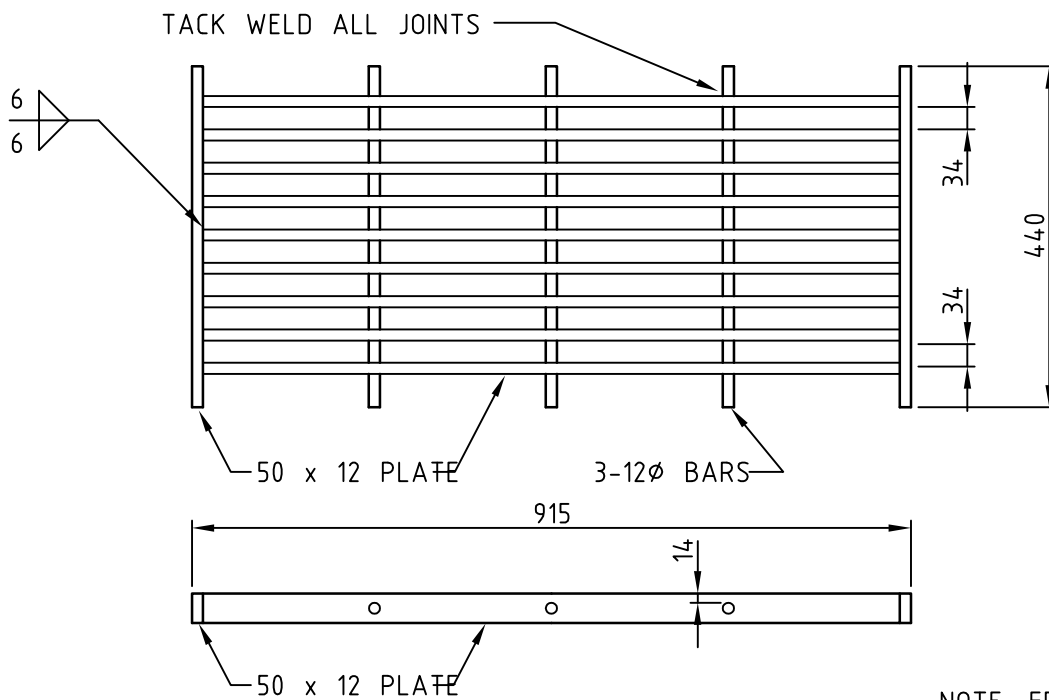
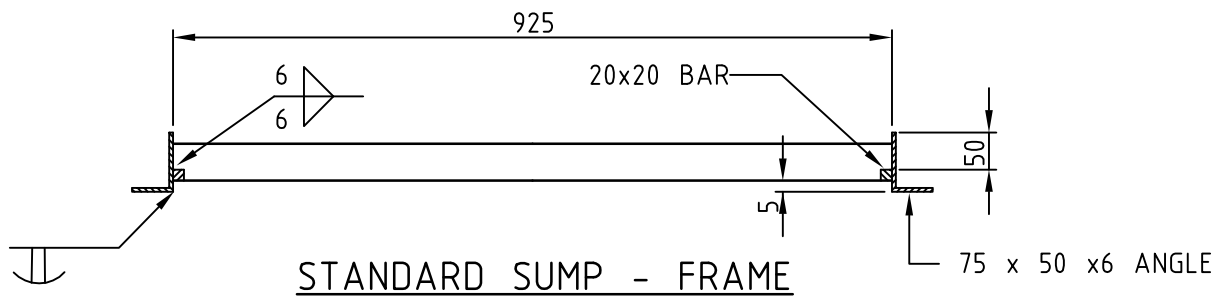
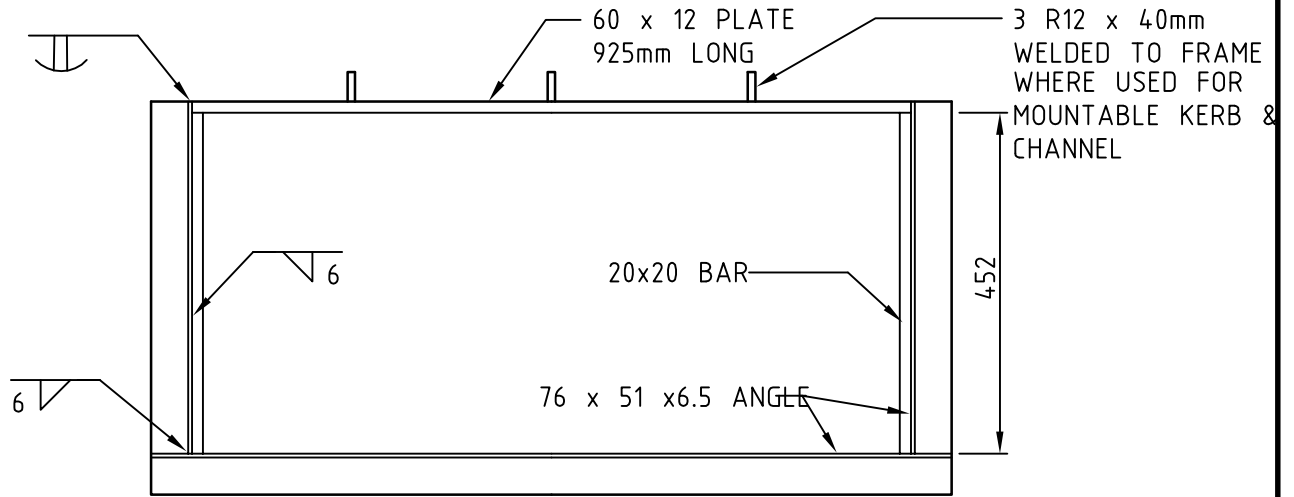

NOTE: FRAME AND GRILL
TO BE MILD STEEL

STANDARD SUMP - GRATING

**NELSON
CITY
COUNCIL**

STANDARD SUMP FRAME & GRILL

INFRASTRUCTURE DIVISION

PLAN No.

APPROVED

21/207

.....
MANAGER INFRASTRUCTURAL ASSETS DATE

SHEET 3

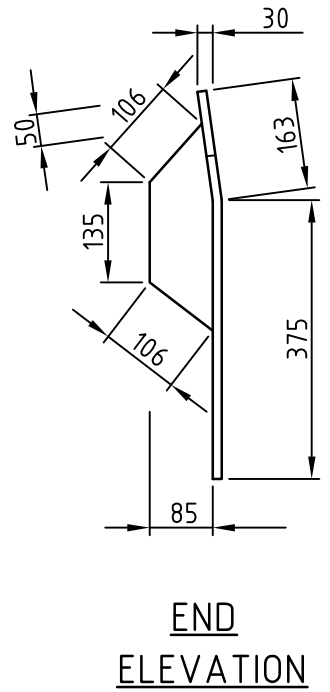
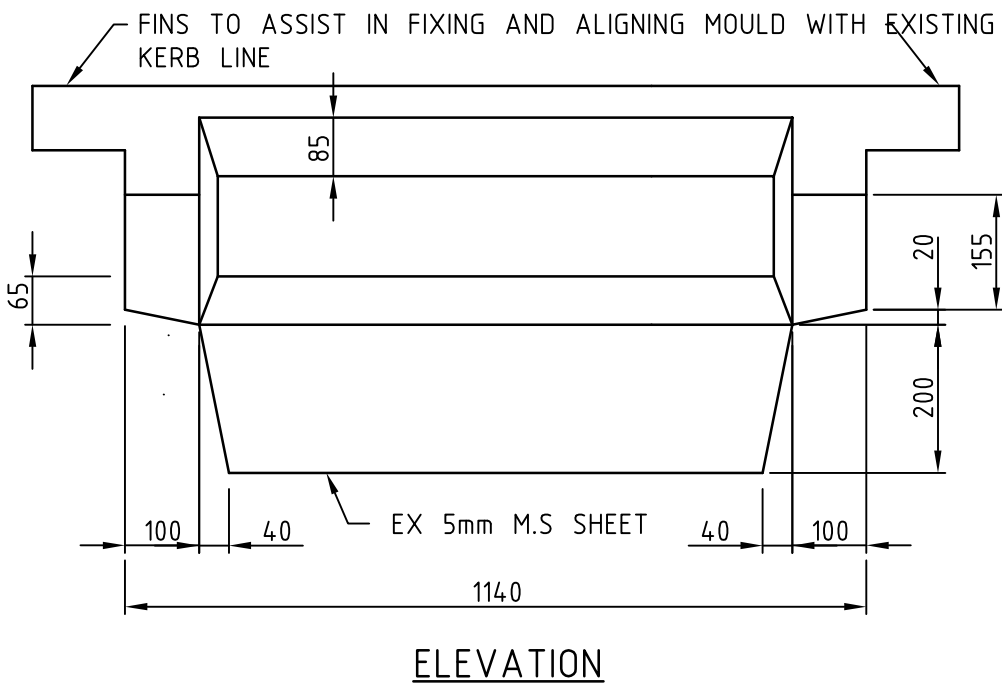
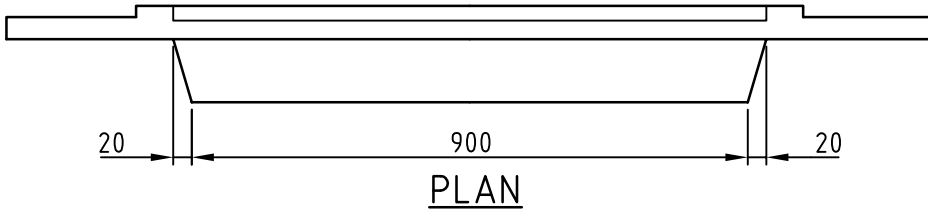

NOTE
DIMENSIONS ARE FOR BACK FACE.

| | | |
|------------------------------------|--|---------------|
| NELSON CITY COUNCIL | STANDARD SUMP TOP MOULD FOR STANDARD KERB & CHANNEL | |
| | INFRASTRUCTURE DIVISION | PLAN No. |
| | APPROVED | 21/207 |
| | MANAGER INFRASTRUCTURAL ASSETS DATE | SHEET 4 |

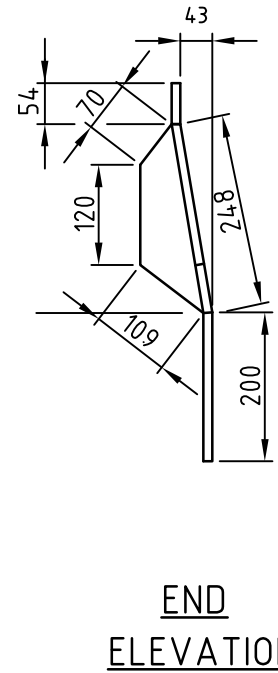
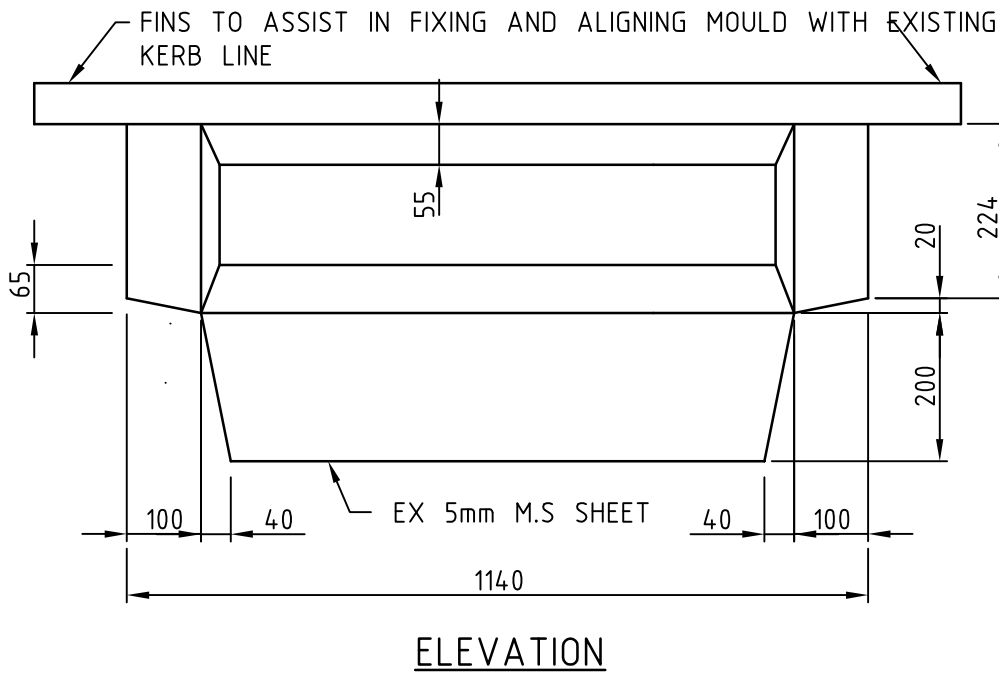
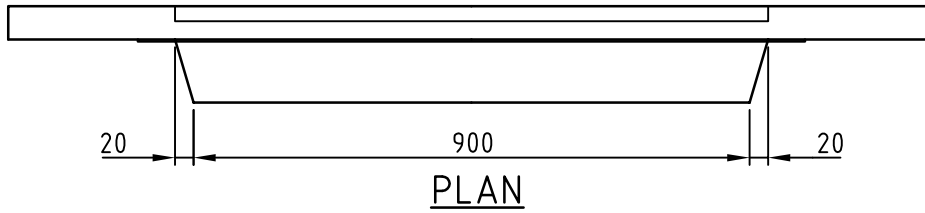

NOTE
DIMENSIONS ARE FOR BACK FACE.

**NELSON
CITY
COUNCIL**

**STANDARD SUMP TOP MOULD FOR
STANDARD MOUNTABLE KERB**

INFRASTRUCTURE DIVISION

APPROVED

.....
MANAGER INFRASTRUCTURAL ASSETS DATE

PLAN No.

21/207

SHEET 5

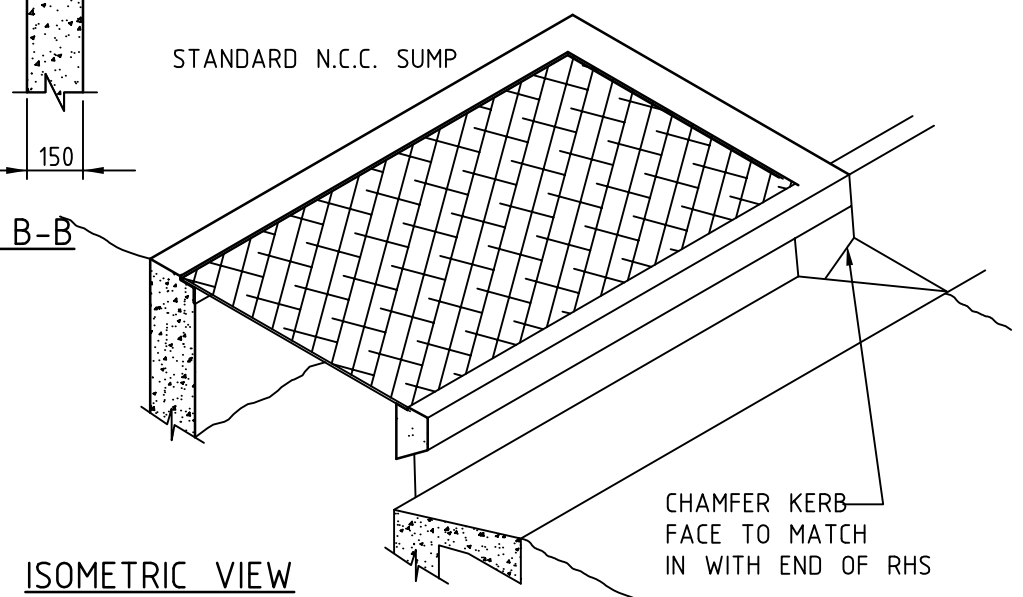
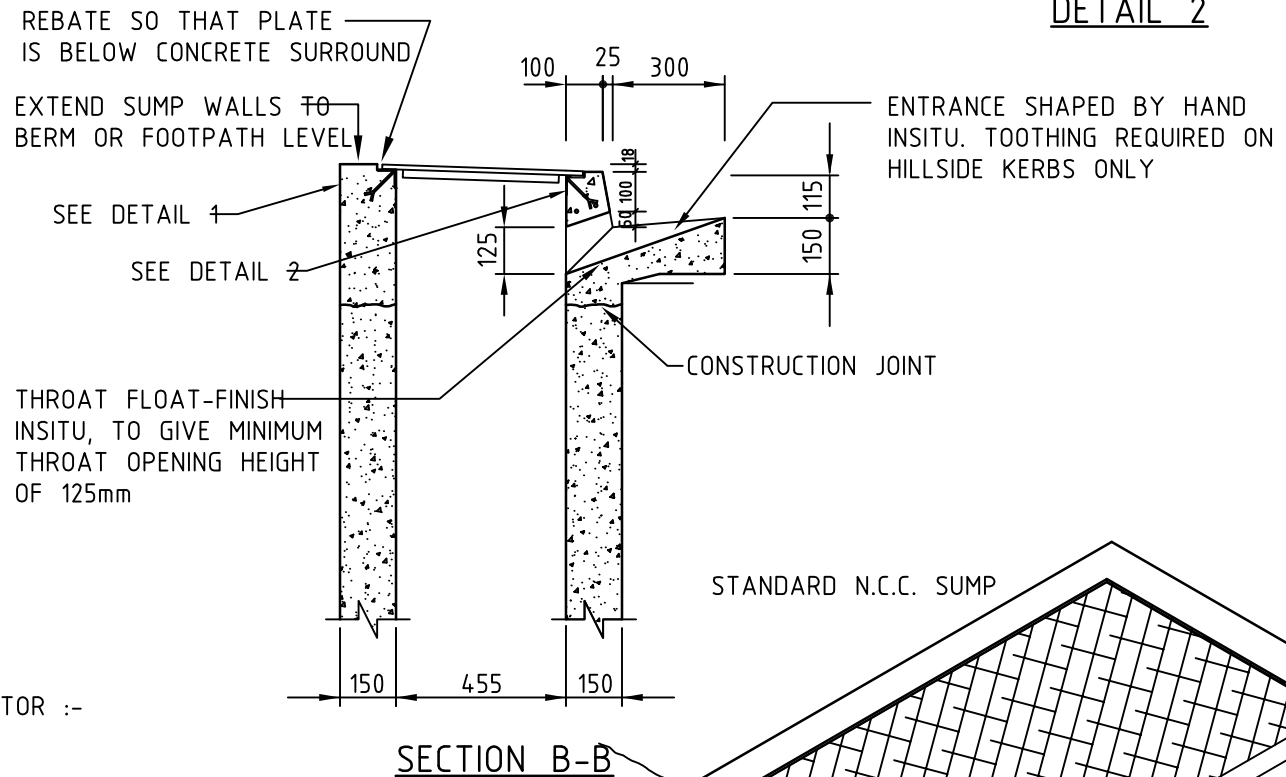
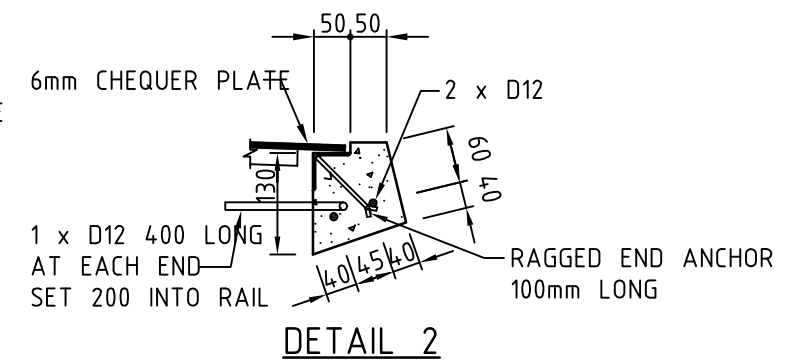
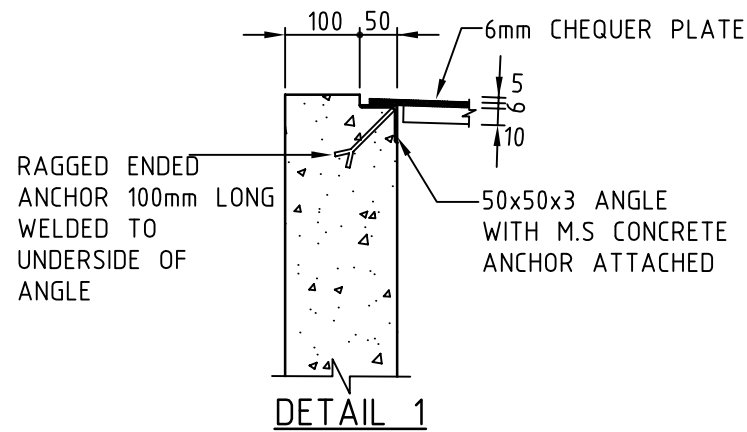
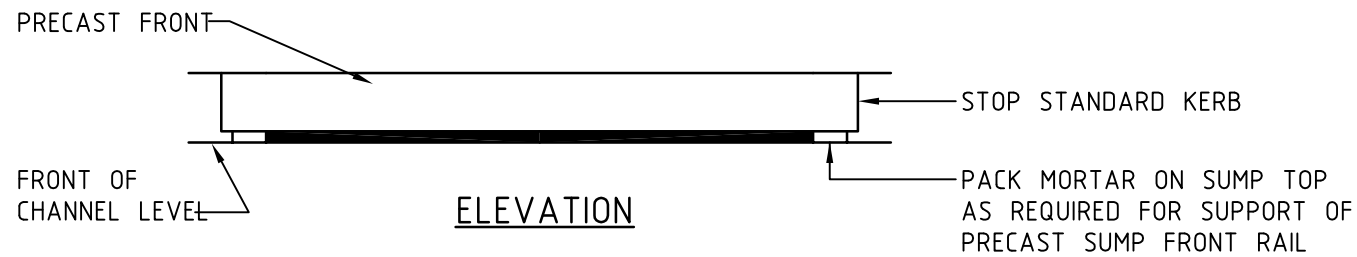
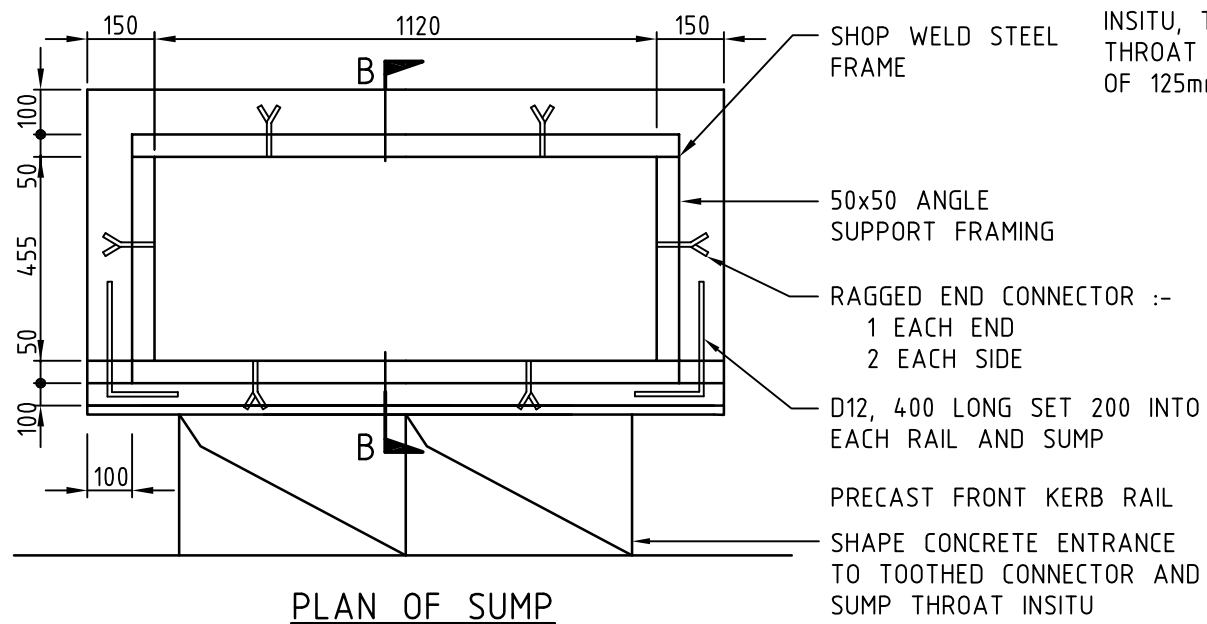
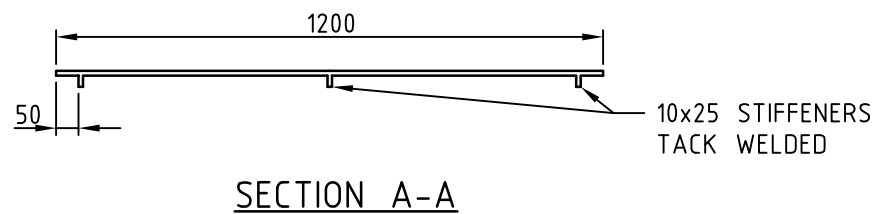
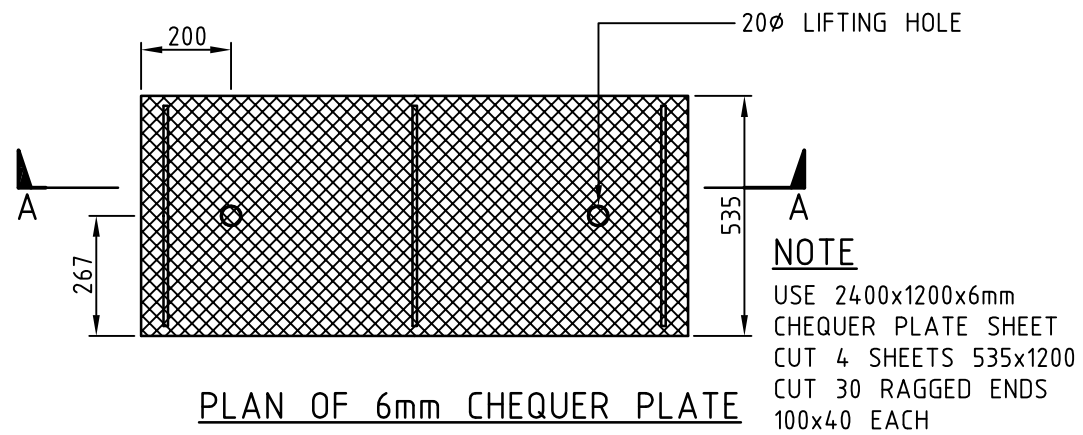

xx ALTERNATIVELY FOR VEHICLE LOADING 150mm THICK REINFORCED CONCRETE COVER SLAB WITH A PICTON TOP CAST IN MAY BE USED. THE REINFORCEMENT SHALL BE TO A SPECIFIC DESIGN

**NELSON
CITY
COUNCIL**

BERM SUMP

INFRASTRUCTURE DIVISION

PLAN No.

APPROVED

21/207

MANAGER INFRASTRUCTURAL ASSETS DATE

SHEET 6

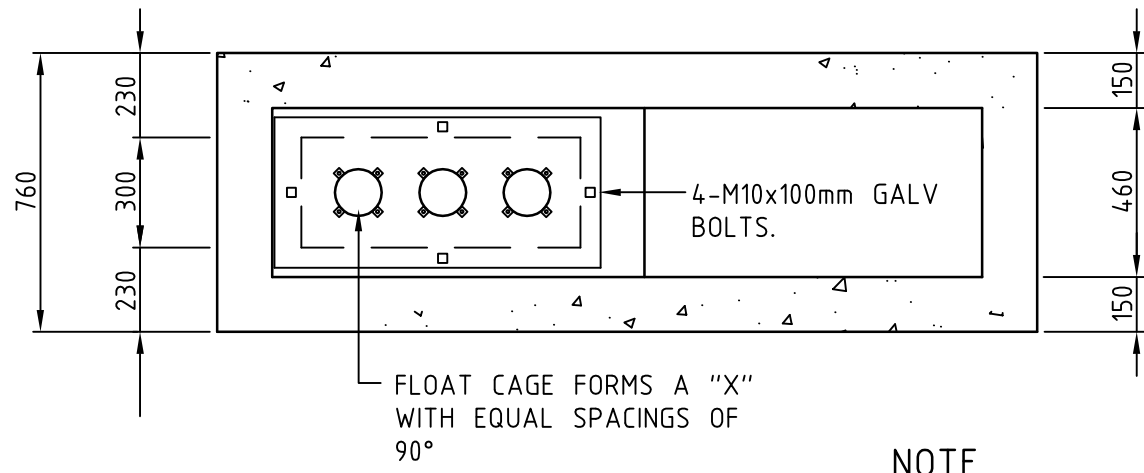

TYPICAL PLAN SECTION

NOTE
PRIME ALL STEELWORK SURFACES WITH CORROLESS RUST STABILISER "S2"
USE RESCUE STEEL ON ALL BOLTS

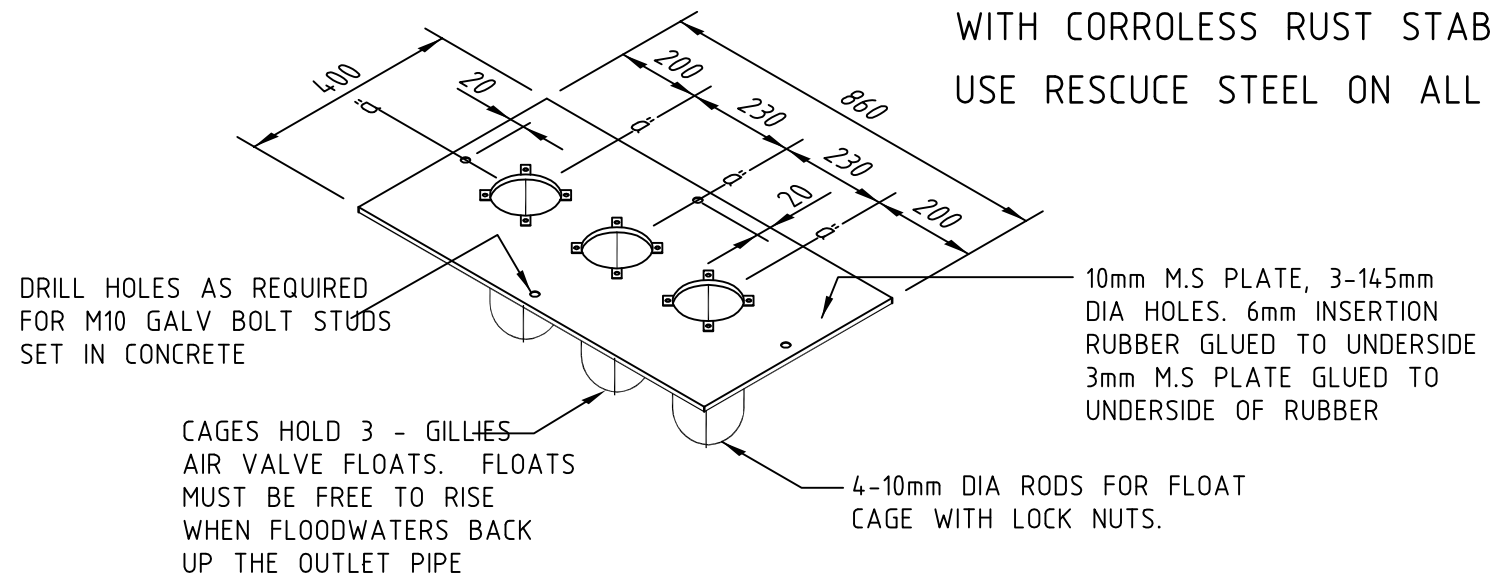

FLOAT CAGE & SUPPORT DETAIL

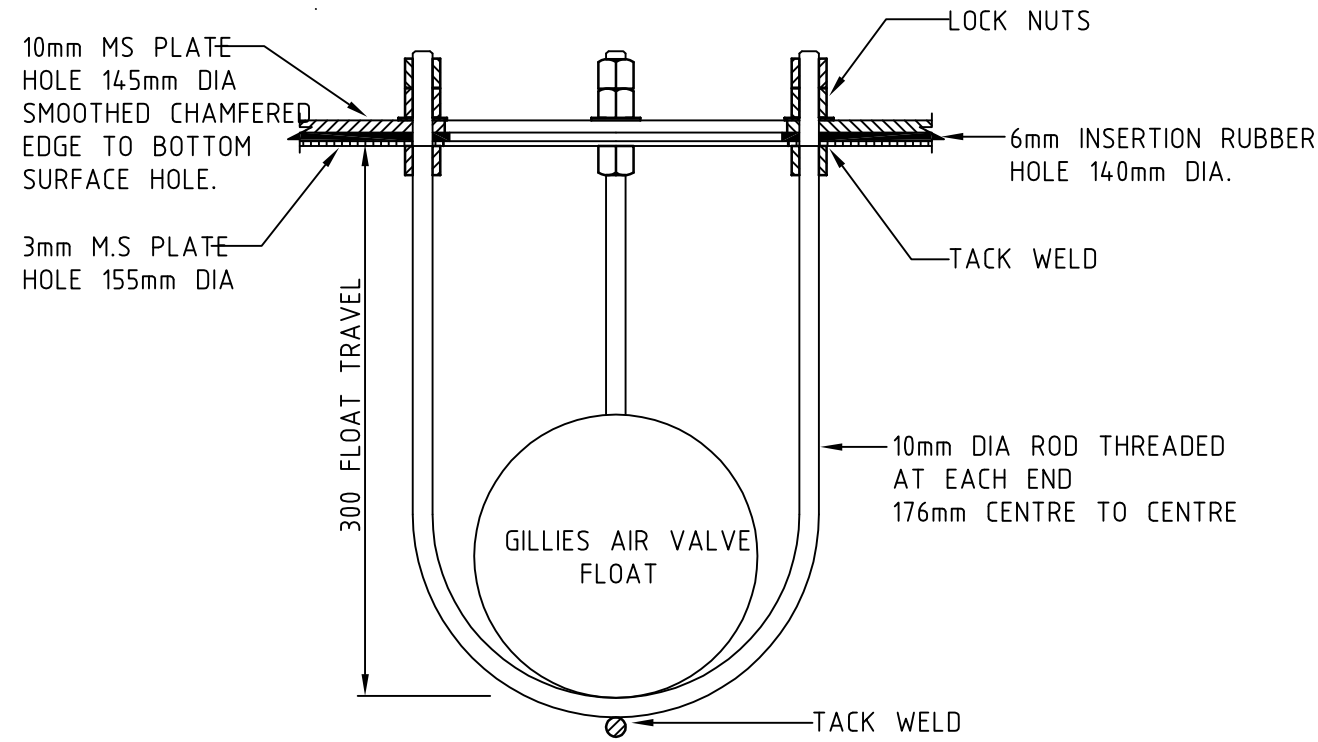

FLOAT CAGE DETAIL

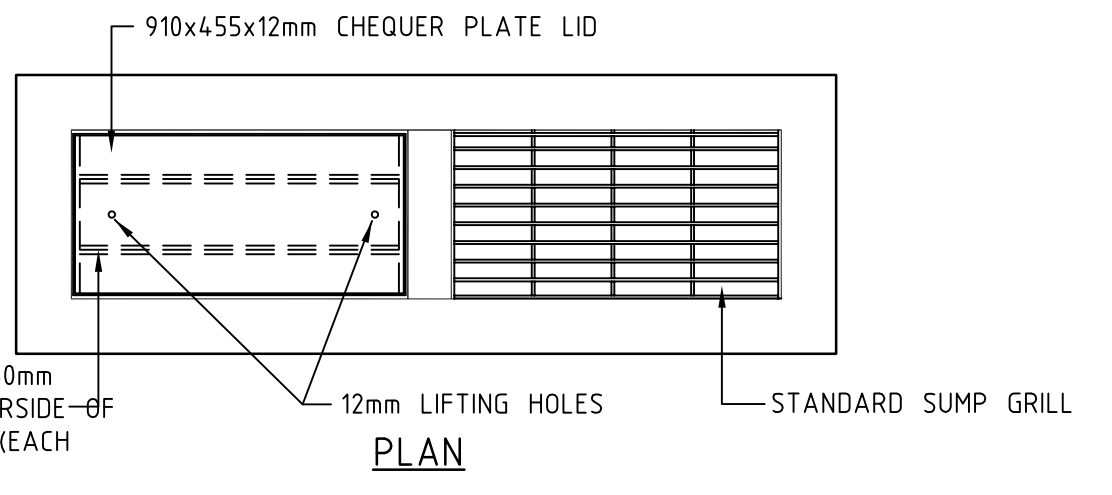

PLAN

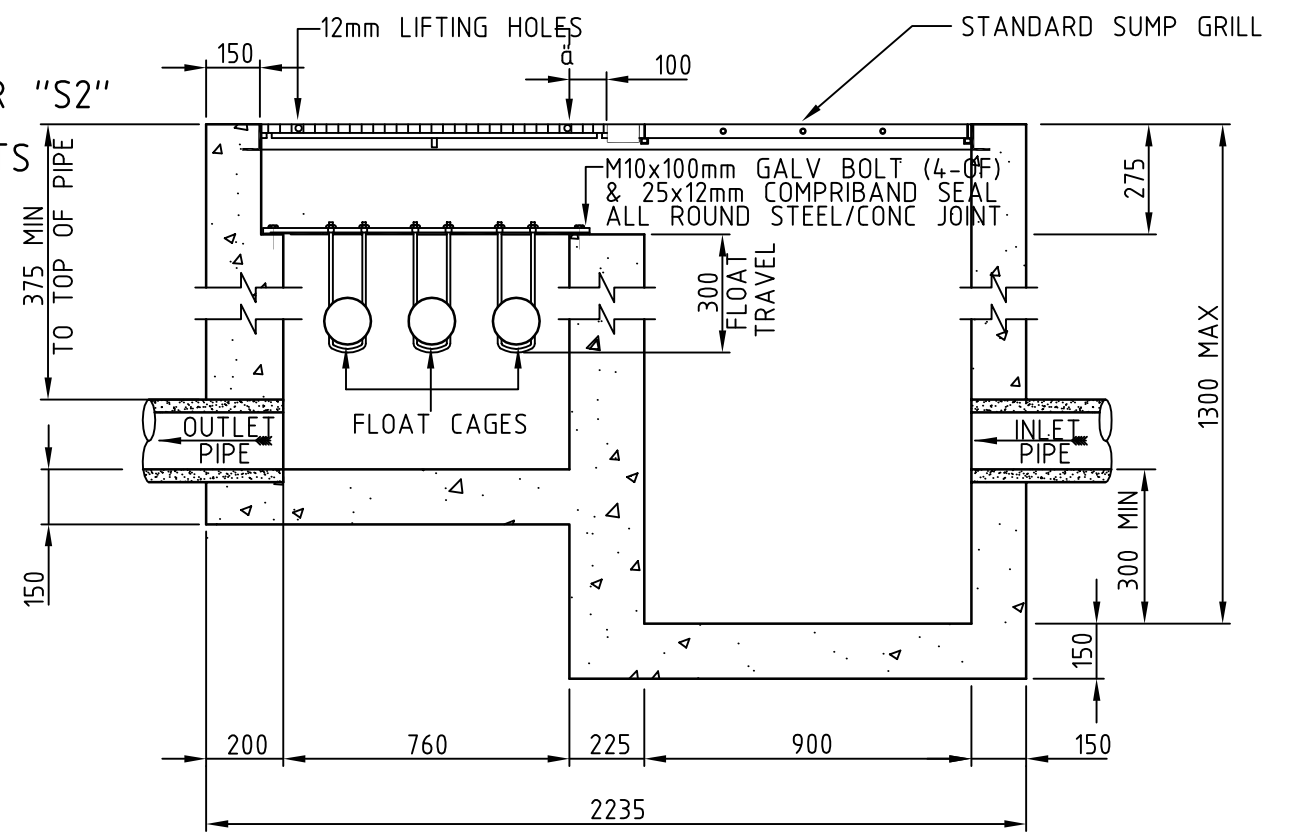

TYPICAL ELEVATION SECTION

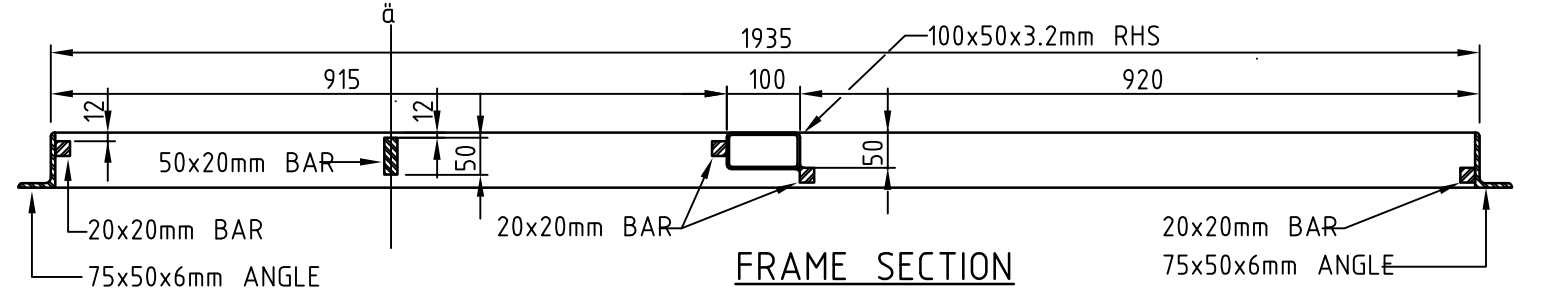

FRAME SECTION

| | | |
|----------------------------|--|---------------|
| NELSON CITY COUNCIL | STANDARD SUMP WITH NON-RETURN CHAMBER | |
| | INFRASTRUCTURE DIVISION | PLAN No. |
| | APPROVED MANAGER INFRASTRUCTURAL ASSETS DATE | 21/207 |
| | | SHEET 7 |

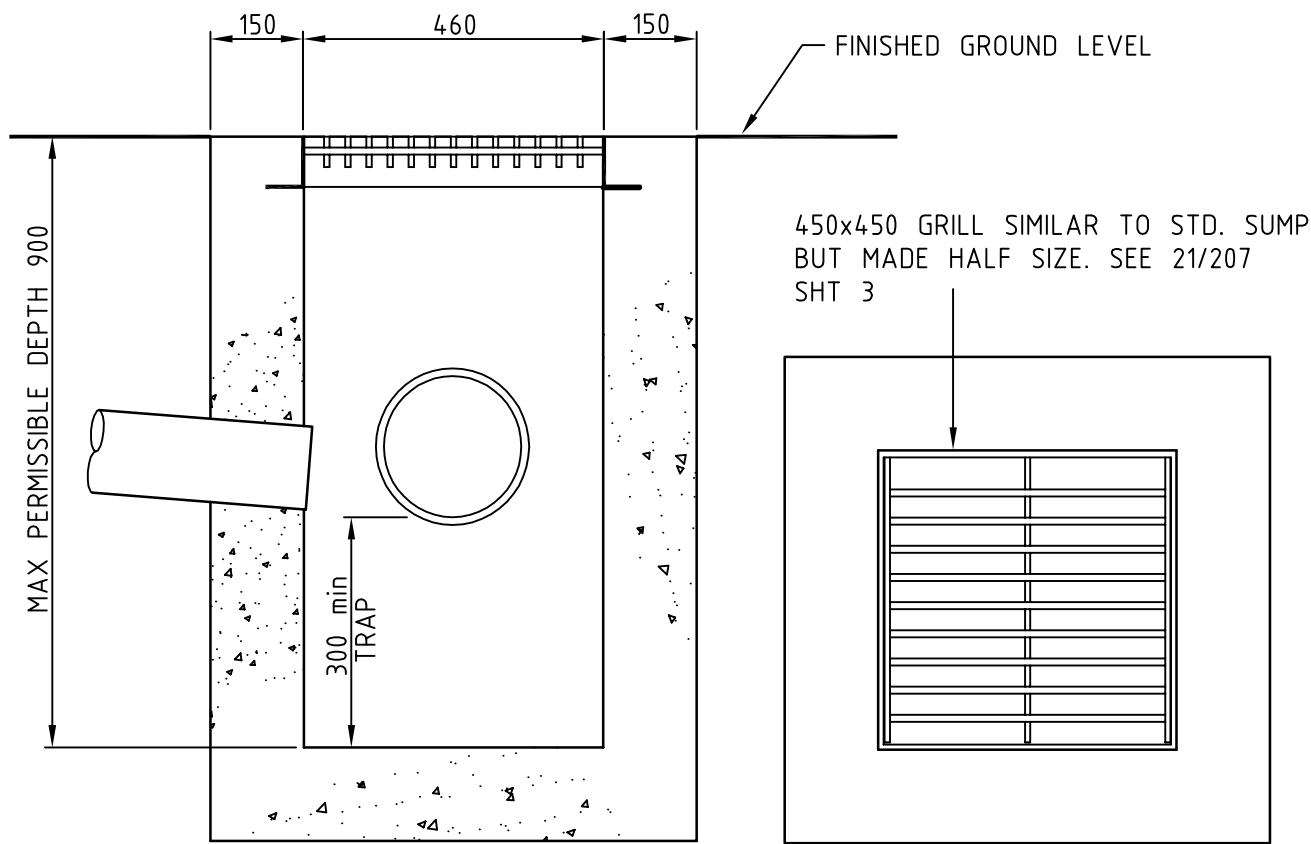

SECTION

PLAN

NOTE
 WHERE PIPE DEPTH REQUIRES SUMP DEPTH IN EXCESS OF 900mm A STANDARD 940 x 460 mm SUMP SHALL BE PROVIDED.

| | | |
|------------------------------------|---|--|
| NELSON CITY COUNCIL | YARD SUMP | |
| | INFRASTRUCTURE DIVISION APPROVED | PLAN No. 21/207 SHEET 8 |
| | MANAGER INFRASTRUCTURAL ASSETS | DATE |

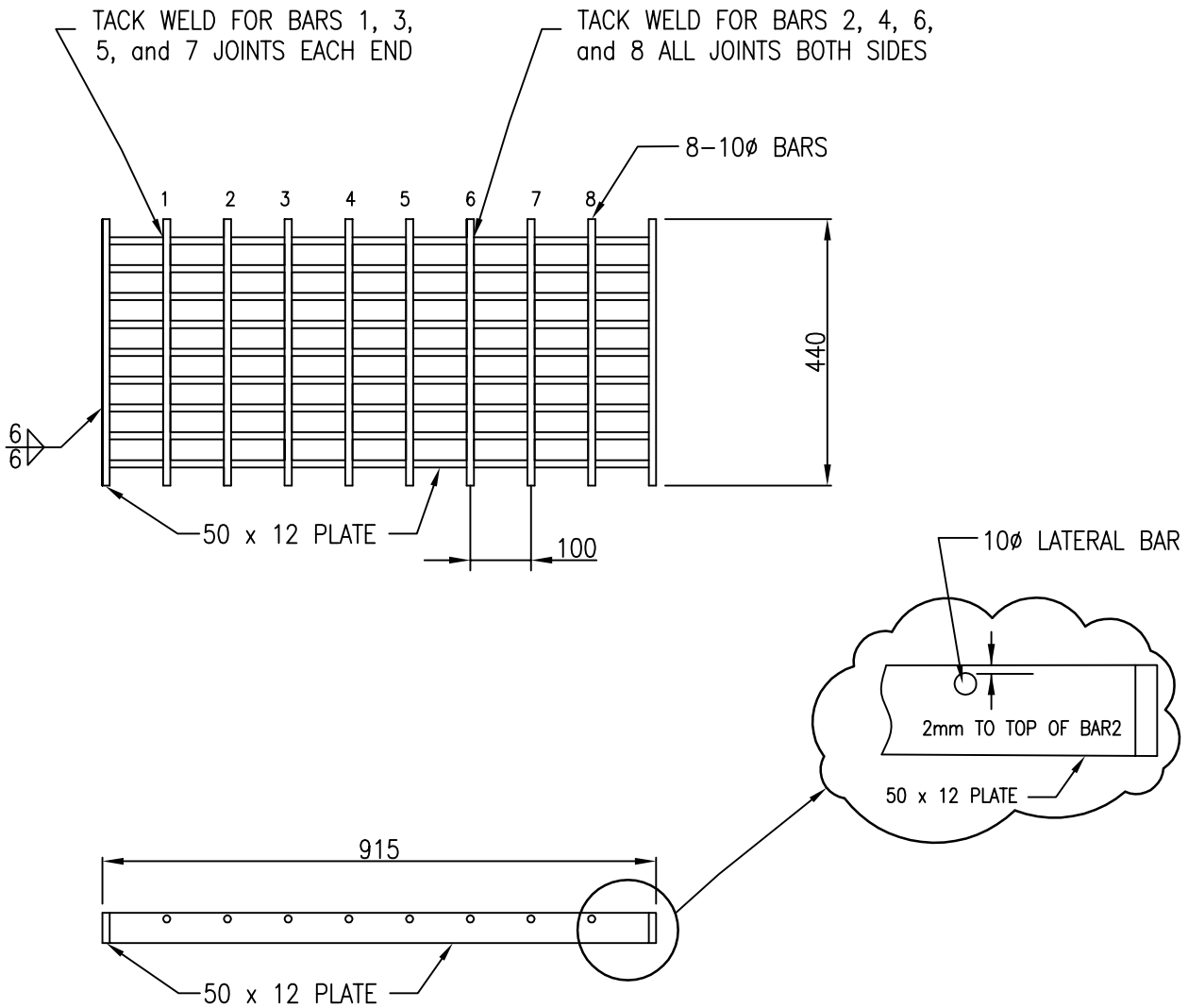

CYCLE FRIENDLY SUMP – GRATING

NOTES:

- 1) LOCATION OF CYCLE FRIENDLY SUMP GRILL IS AT THE COUNCILS DISCRETION
- 2) GRILL TO BE MILD STEEL
- 3) DRAWING NOT TO SCALE

**NELSON
CITY
COUNCIL**

CYCLE FRIENDLY SUMP GRATE

INFRASTRUCTURE DIVISION

APPROVED

.....
MANAGER INFRASTRUCTURAL ASSETS DATE

PLAN No.

21/207

SHEET 9

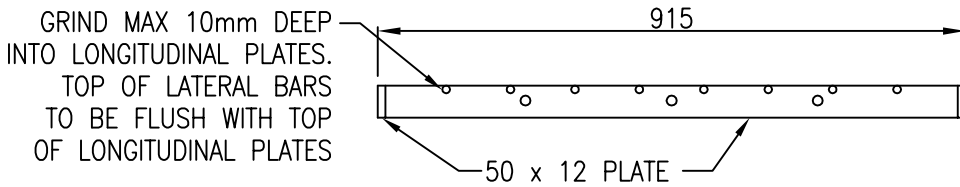
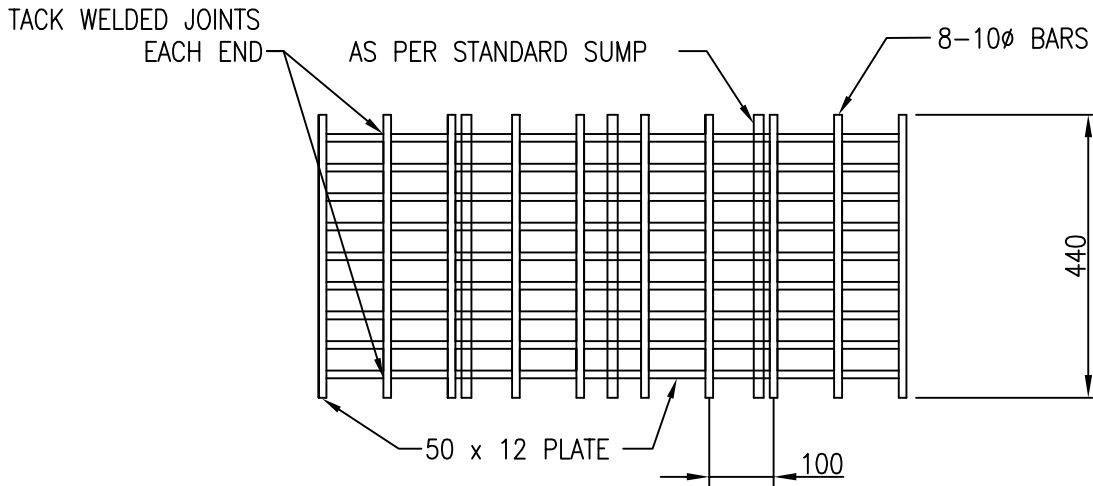

CYCLE FRIENDLY SUMP – GRATING

NOTES:

- 1) LOCATION OF CYCLE FRIENDLY SUMP GRILL AT COUNCIL'S DISCRETION
- 2) THE SUMP GRATE IS A STANDARD SUMP GRATE AS PER DRAWING 21/207 SHEET 3 WITH THE ADDITION OF 8 LATERAL BARS
- 3) FRAME AND GRILL TO BE MILD STEEL
- 4) DRAWING NOT TO SCALE

**NELSON
CITY
COUNCIL**

CYCLE FRIENDLY SUMP GRATE
Modification of Standard Sump Grate

INFRASTRUCTURE DIVISION

APPROVED

.....
MANAGER INFRASTRUCTURAL ASSETS DATE

PLAN No.

21/207

SHEET 10

NOTES:

1. THE STANDARD SILT & OIL TRAP IS DESIGNED TO SERVE SMALL INSTALLATIONS SUCH AS TRUCK DEPOTS ETC. (MAJOR INSTALLATIONS WILL REQUIRE SPECIFIC DESIGN.)
2. SILT & OIL TRAP IS MADE UP OF FOUR STANDARD PRECAST SUMP UNITS.
3. LIDS TO BE PRECAST REINFORCED CONCRETE LID MASS APPROXIMATELY 226kg.
4. OIL CAPACITY 390 LITRES. SILT VOLUME 0.1m³
5. DRAIN PIPE WORK MIN 100MM DIA PVC.
6. VENT PIPE WORK MIN 40mm DIA PVC, ABOVE GROUND VENTS MAY BE GALVANISED STEEL IF IN AN EXPOSED POSITION.
7. A CONTINUOUS MORTAR PAD MINIMUM THICKNESS 10mm, SHALL BE LAID ROUND THE TOP OF EACH SUMP UNIT TO ALLOW FOR SHAPING TO THE REQUIRED FINISHED GROUND LEVEL.
A COMPRESSIBLE SEALANT STRIP OF COMPRIBAND OR SIMILAR APPROVED SHALL BE LAID ON EACH MORTAR PAD.
8. WHERE A STEAM CLEANING OPERATION OR DETERGENTS OR DEGREASER ARE USED:
 - * AN APPLICATION FORM TO DISCHARGE TRADE WASTE FROM A SILT & OIL TRAP TO THE SEWERAGE SYSTEM SHALL BE SUBMITTED TO THE ENGINEERING MANAGER FOR HIS/HER APPROVAL.
 - * STORMWATER SHALL NOT BE ALLOWED TO DISCHARGE TO THE SEWERAGE SYSTEM.
9. BUNDED AREAS AROUND FUEL STORAGE AREAS SHOULD DISCHARGE TO THE STORMWATER VIA A SUITABLY DESIGNED OIL INTERCEPTOR WITH AN APPROPRIATE SHUT-OFF VALVE INSITU.
10. BUND TO BE 200mm HIGH AROUND SITE.

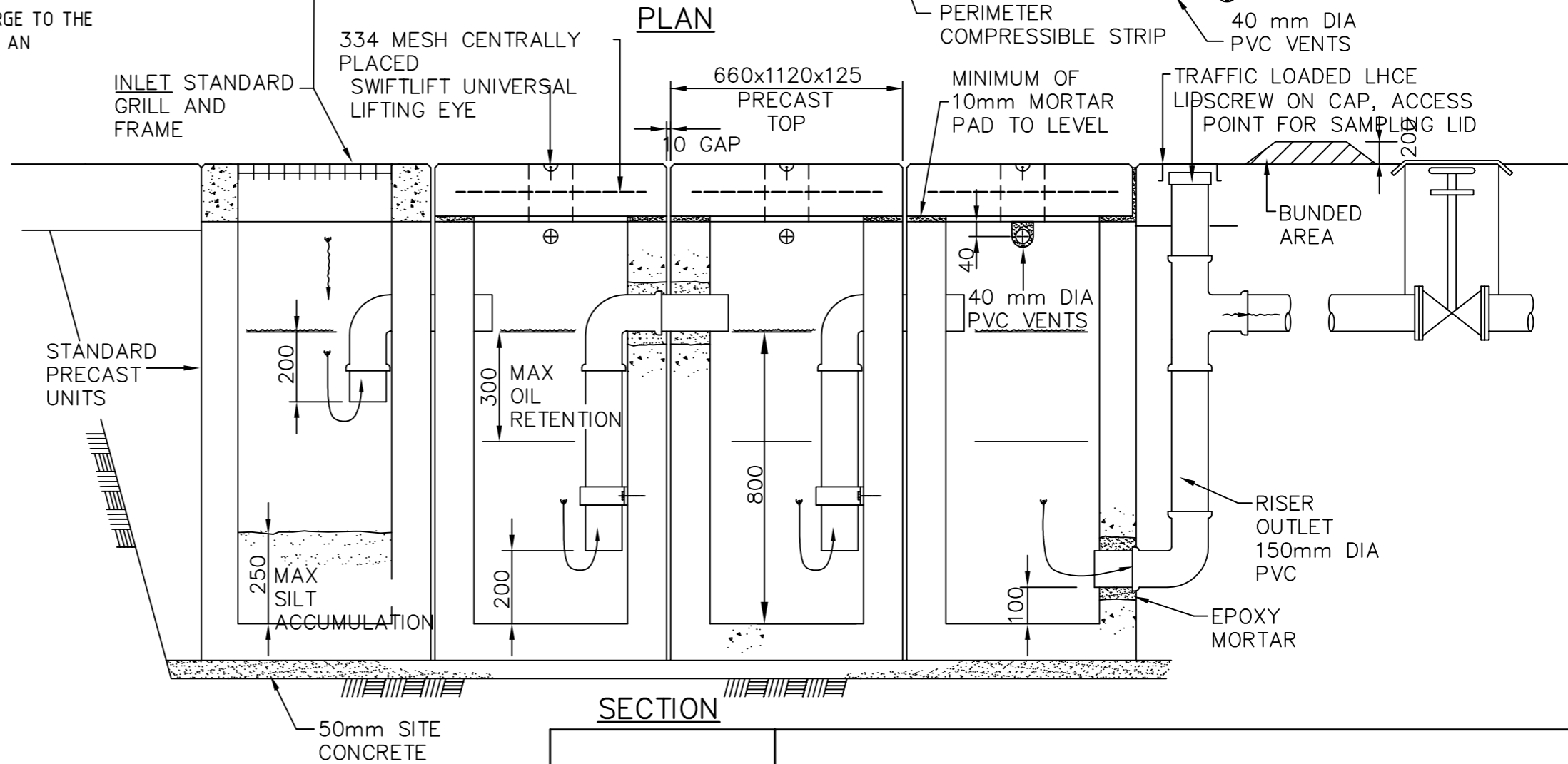
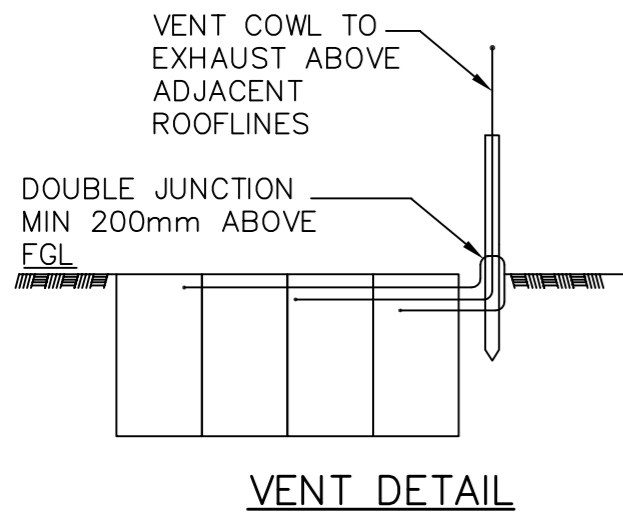
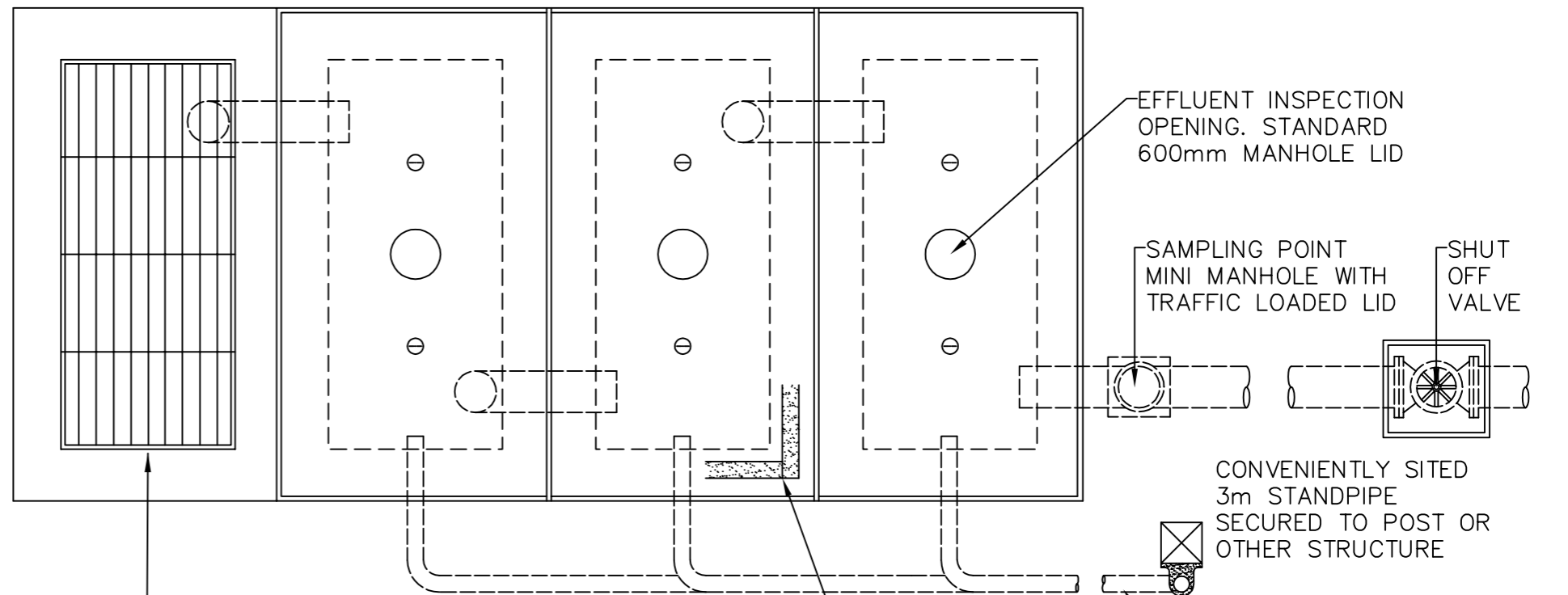

| | | |
|----------------------------|--|--------------------------------------|
| NELSON CITY COUNCIL | SILT & OIL TRAP | |
| | INFRASTRUCTURE DIVISION APPROVED _____ MANAGER INFRASTRUCTURAL ASSETS DATE | PLAN No. 21/208 SHEET 1 |

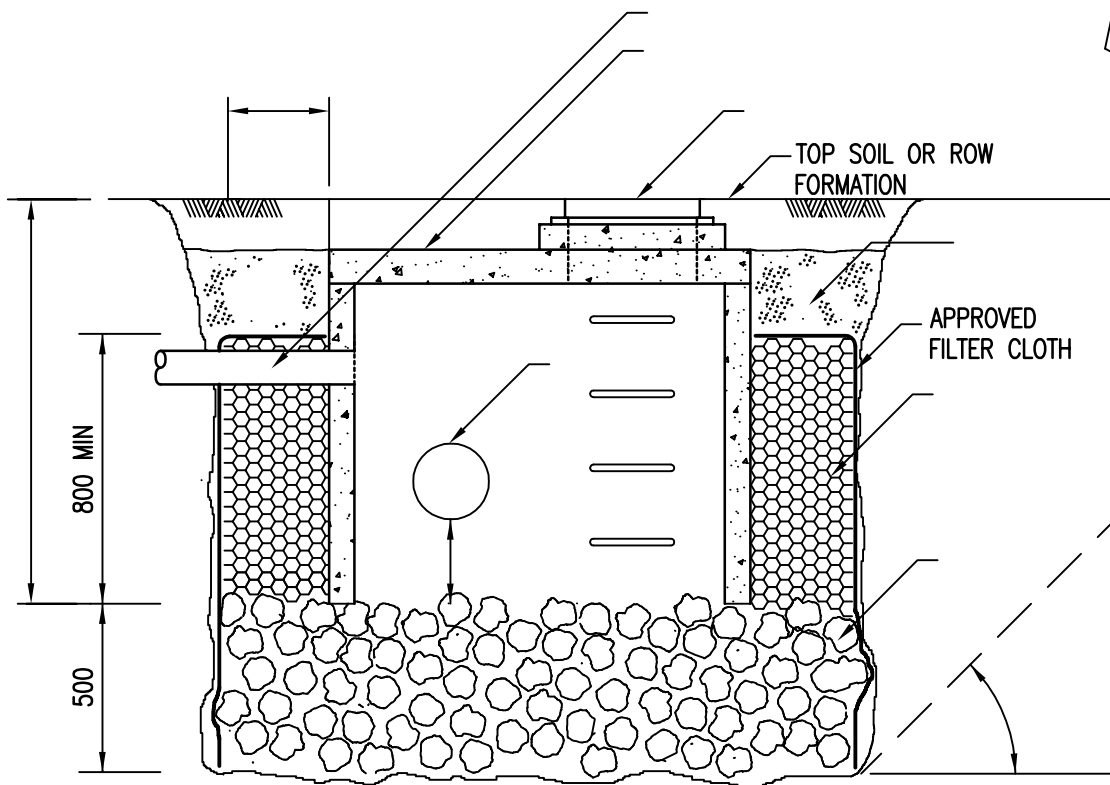

**NELSON
CITY
COUNCIL**

STANDARD SOAK PIT DETAIL

INFRASTRUCTURE DIVISION

PLAN No.

APPROVED

21/209

.....
MANAGER INFRASTRUCTURAL ASSETS DATE

SHEET 1

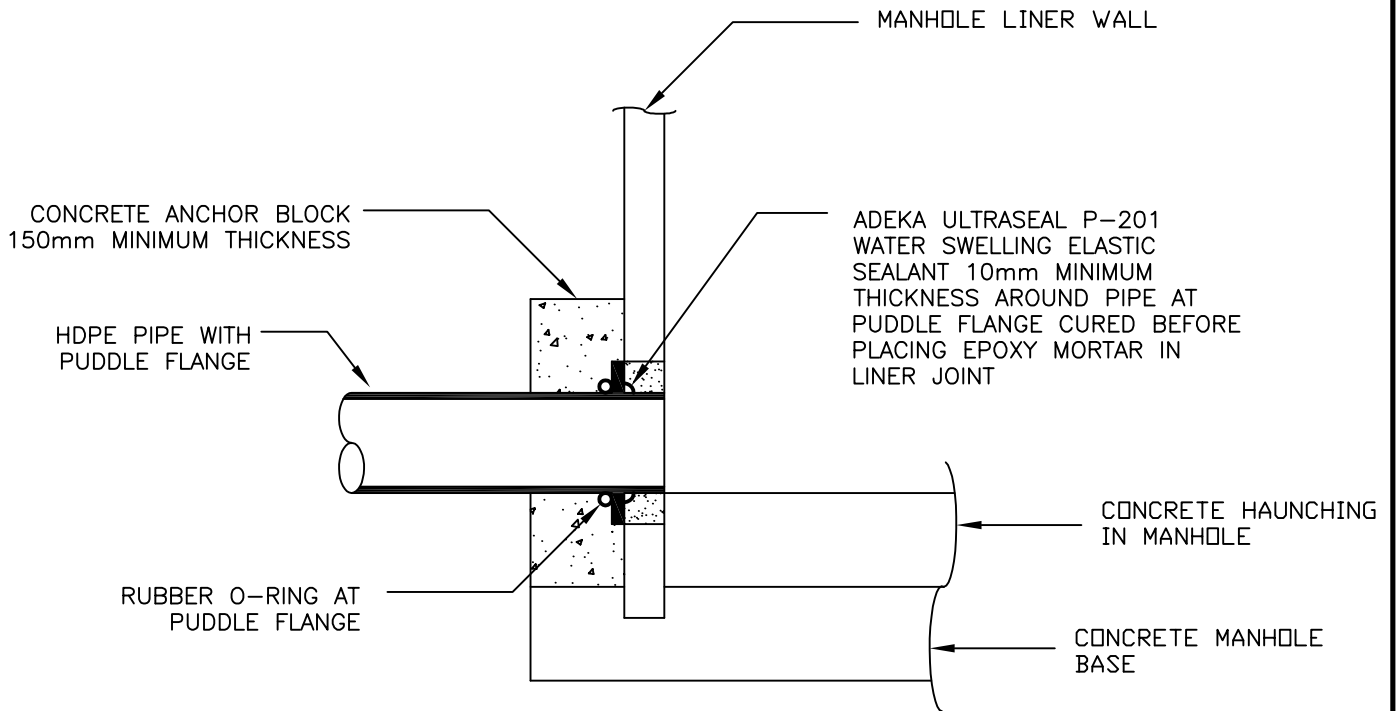

NOTE:

ALL WORKS TO BE INSPECTED BY NCC BEFORE CONCRETE ANCHOR BLOCK HAS BEEN POURED

| | | |
|------------------------------------|---|--|
| NELSON CITY COUNCIL | SEWER MANHOLE WATER TIGHTNESS & PIPE RESTRAINT DETAIL FOR HDPE PIPES | |
| | INFRASTRUCTURE DIVISION | |
| | APPROVED MANAGER INFRASTRUCTURAL ASSETS | PLAN No. 21/209 SHEET 2 |

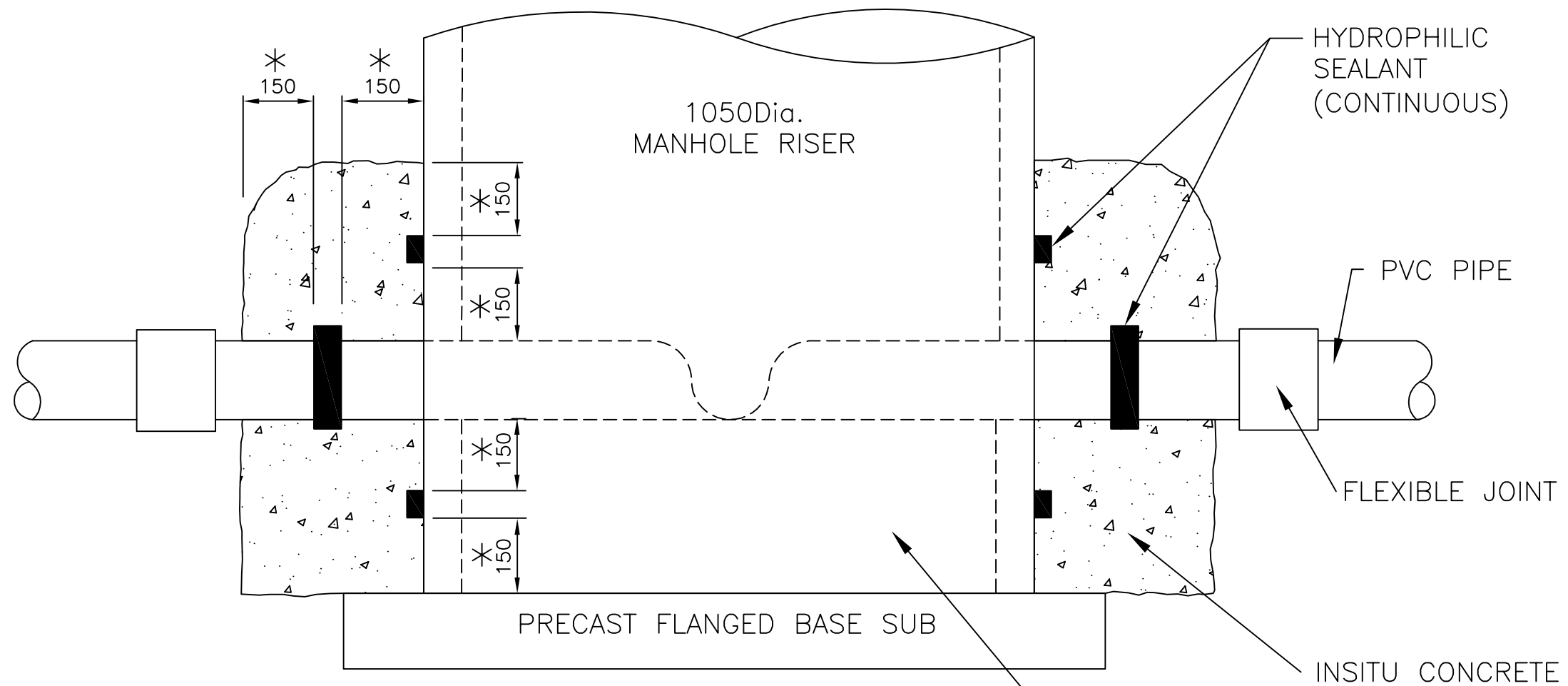

* MINIMUM COVER TO SEALANT FROM FREE EDGE OF INSITU CONCRETE

DEEPEN MANHOLE CONCRETE BASE TO ALLOW FOR CONCRETE COVERS FOR SEALANT BELOW THE PIPE

NOTES:

1. DETAIL APPLIES TO ALL SEWER MANHOLES WHERE THE SEWER PIPELINE MAY BE DEEPER THAN THE WATER TABLE & WHERE DRAINAGE TRENCH IS NOT POSSIBLE
2. WRAP EACH INCOMING & OUTGOING PIPE WITH HYDROPHILIC SEALANT PRIOR TO CONCRETE POUR
3. HYDROSTATIC WATER TEST EACH SEALED MANHOLE PRIOR TO BACKFILLING MANHOLES
4. ALL WORKS TO BE INSPECTED BY NCC PRIOR TO PLACING OF INSITU CONCRETE

| | | |
|------------------------------------|---|---------------|
| NELSON CITY COUNCIL | SEWER MANHOLE WATER TIGHTNESS DETAIL FOR PVC PIPES | |
| | INFRASTRUCTURE DIVISION | PLAN No. |
| APPROVED | DATE | 21/209 |
| MANAGER INFRASTRUCTURAL ASSETS | DATE | SHEET 3 |

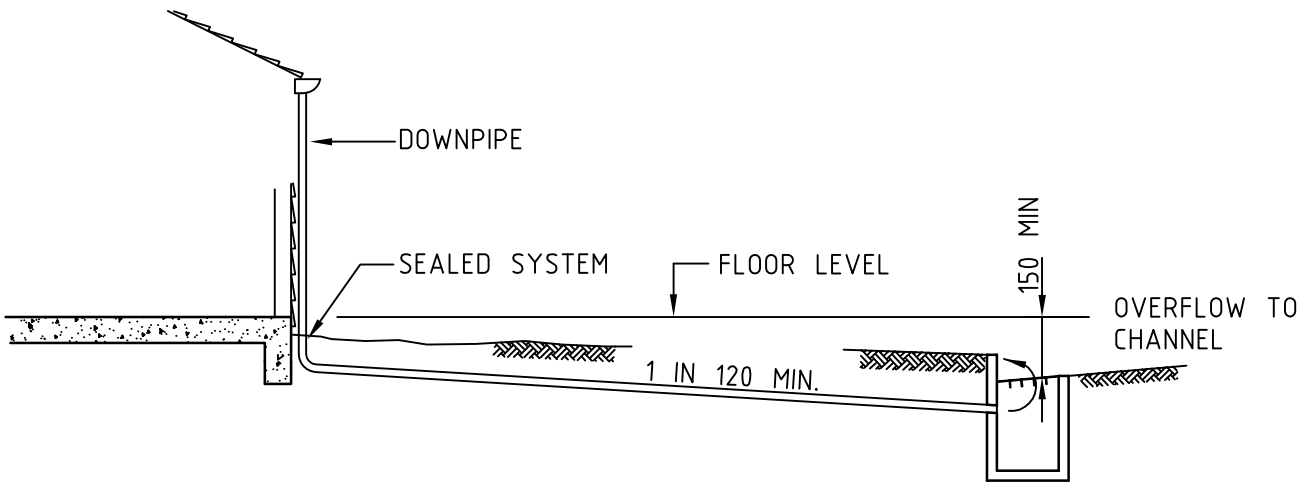

BUBBLE UP SUMP

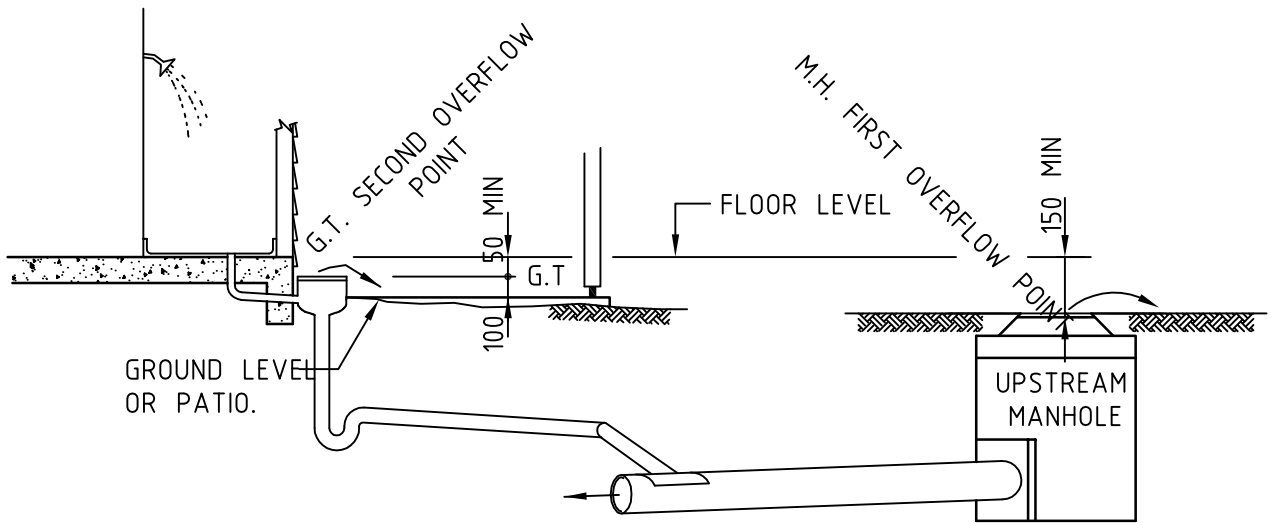

MINIMUM FLOOR LEVELS RELATED TO SEWERAGE OVERFLOW

**NELSON
CITY
COUNCIL**

MISCELLANEOUS DRAINAGE DETAILS

INFRASTRUCTURE DIVISION

PLAN No.

APPROVED

21/210

.....
MANAGER INFRASTRUCTURAL ASSETS DATE

SHEET 1

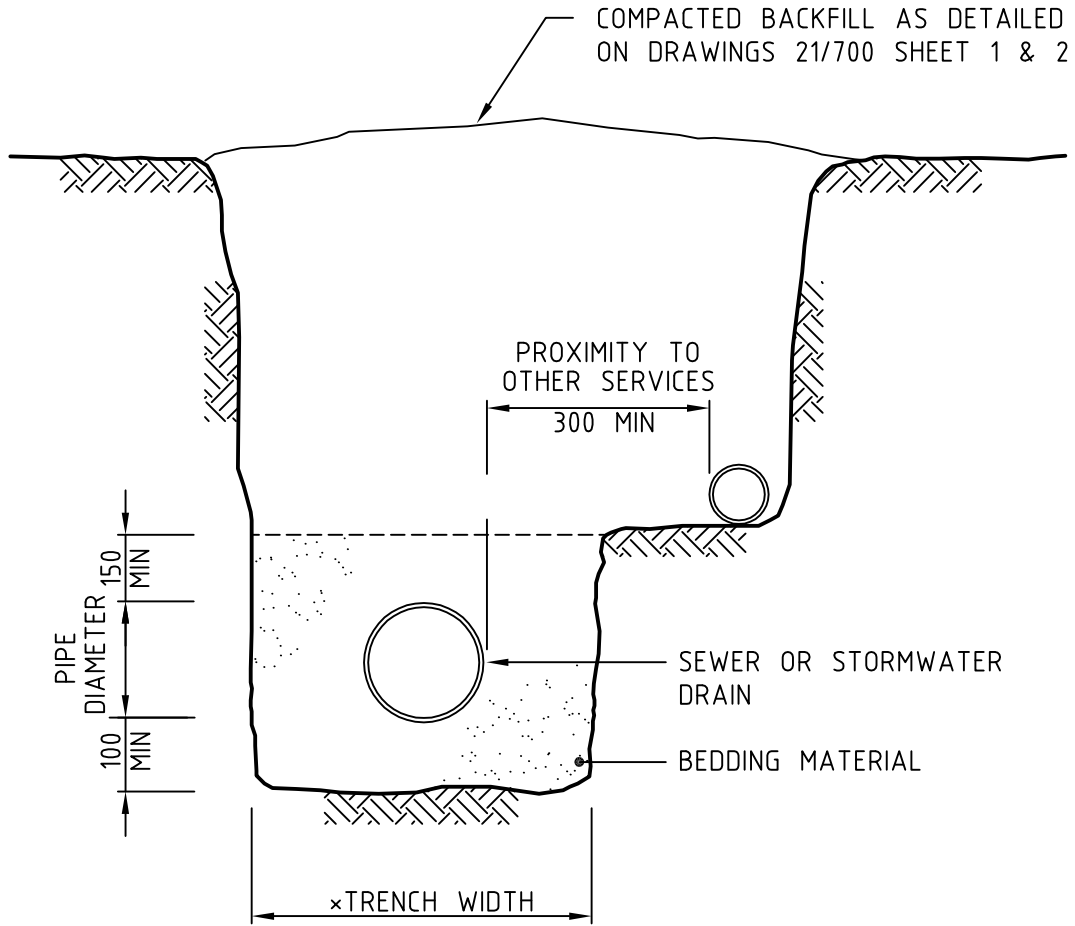

***TRENCH WIDTH**

| NOMINAL DIAMETER DN (mm) | MINIMUM TRENCH SIDE CLEARANCE "lc" TO AS/NZS 2566 |
|--------------------------|---|
| UP TO 150 | 100 |
| 200 - 250 | 150 |
| 300 - 375 | 200 |

THE TRENCH WIDTH SHALL BE THE MINIMUM NECESSARY TO ADEQUATELY AND SAFELY LAY THE PIPE AND TO COMPACT THE SIDE SUPPORT ZONE

**NELSON
CITY
COUNCIL**

**DRAINAGE SHARED TRENCH
CLEARANCES**

INFRASTRUCTURE DIVISION

APPROVED

.....
MANAGER INFRASTRUCTURAL ASSETS DATE

PLAN No.

21/211

SHEET 1

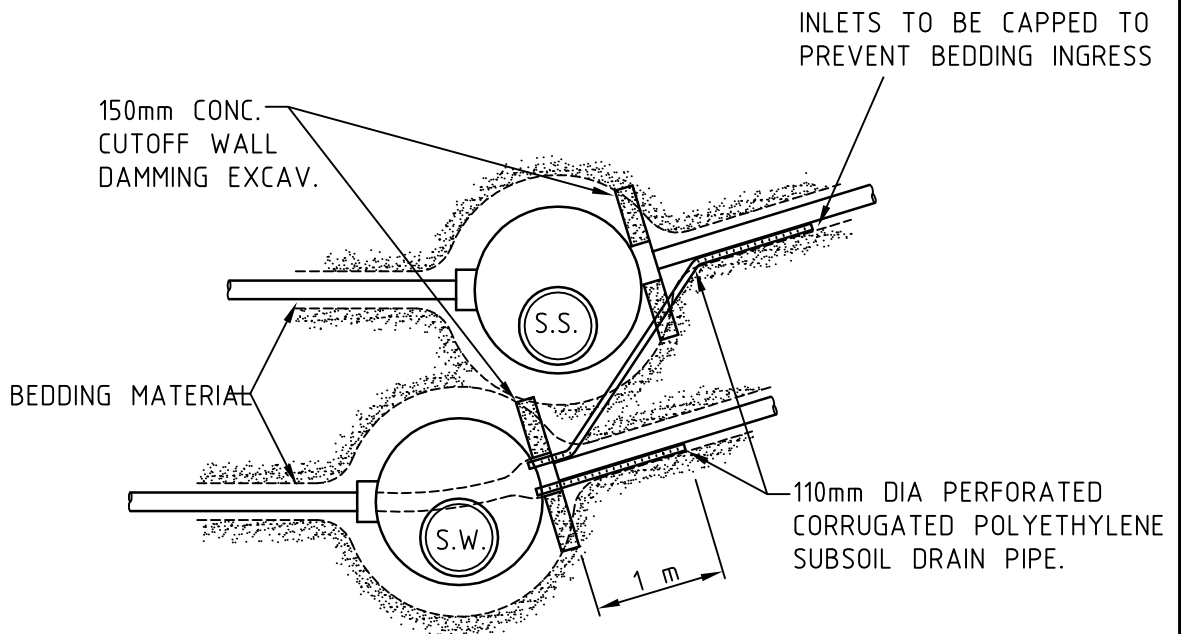

PLAN

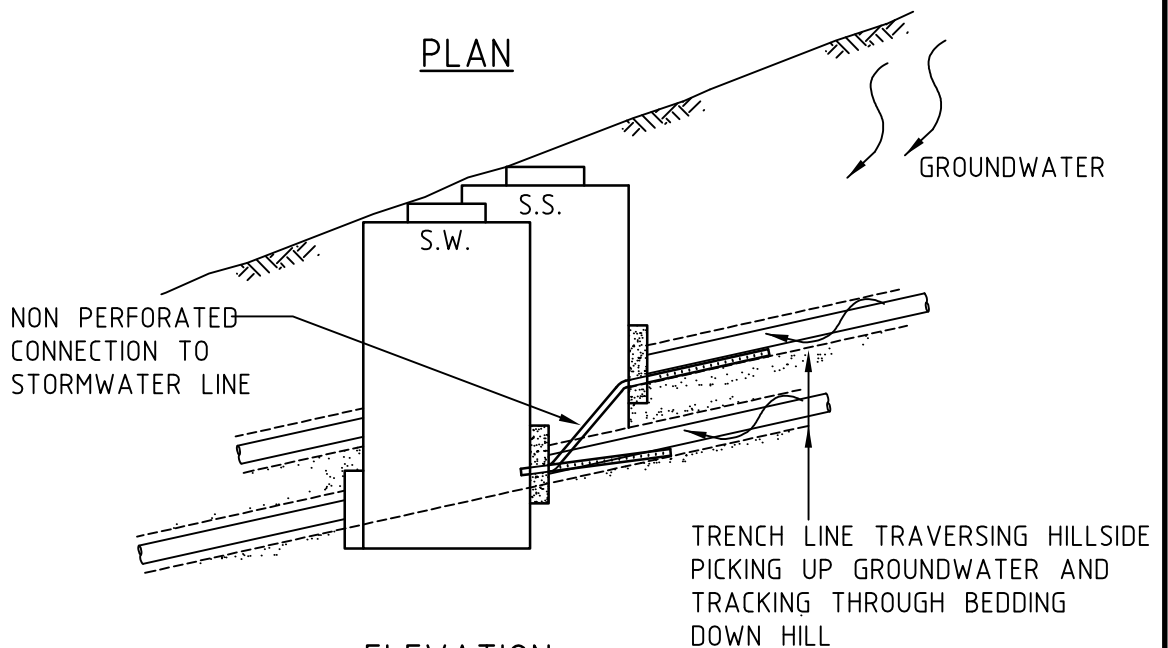

ELEVATION

NOTE:

1. SIMILAR PROVISION FOR DRAINAGE OF CABLE AND WATER TRENCHS MAY BE REQUIRED.
2. STORMWATER TRENCHES TO BE LAID SLIGHTLY DEEPER THAN SEWER TRENCHS WHERE POSSIBLE.
3. WHERE SEWER IS BELOW STORMWATER (WITH NCC APPROVAL ONLY) GRADE SEWER TRENCH OUT TO NEAREST STORMWATER DISCHARGE SOURCE, OR HAVE TRENCH BARRIERS AT 10m CENTRES ALONG TRENCH.

**NELSON
CITY
COUNCIL**

HILLSIDE TRENCH DRAINAGE DETAILS

INFRASTRUCTURE DIVISION

APPROVED

.....
MANAGER INFRASTRUCTURAL ASSETS DATE

PLAN No.

21/212

SHEET 1

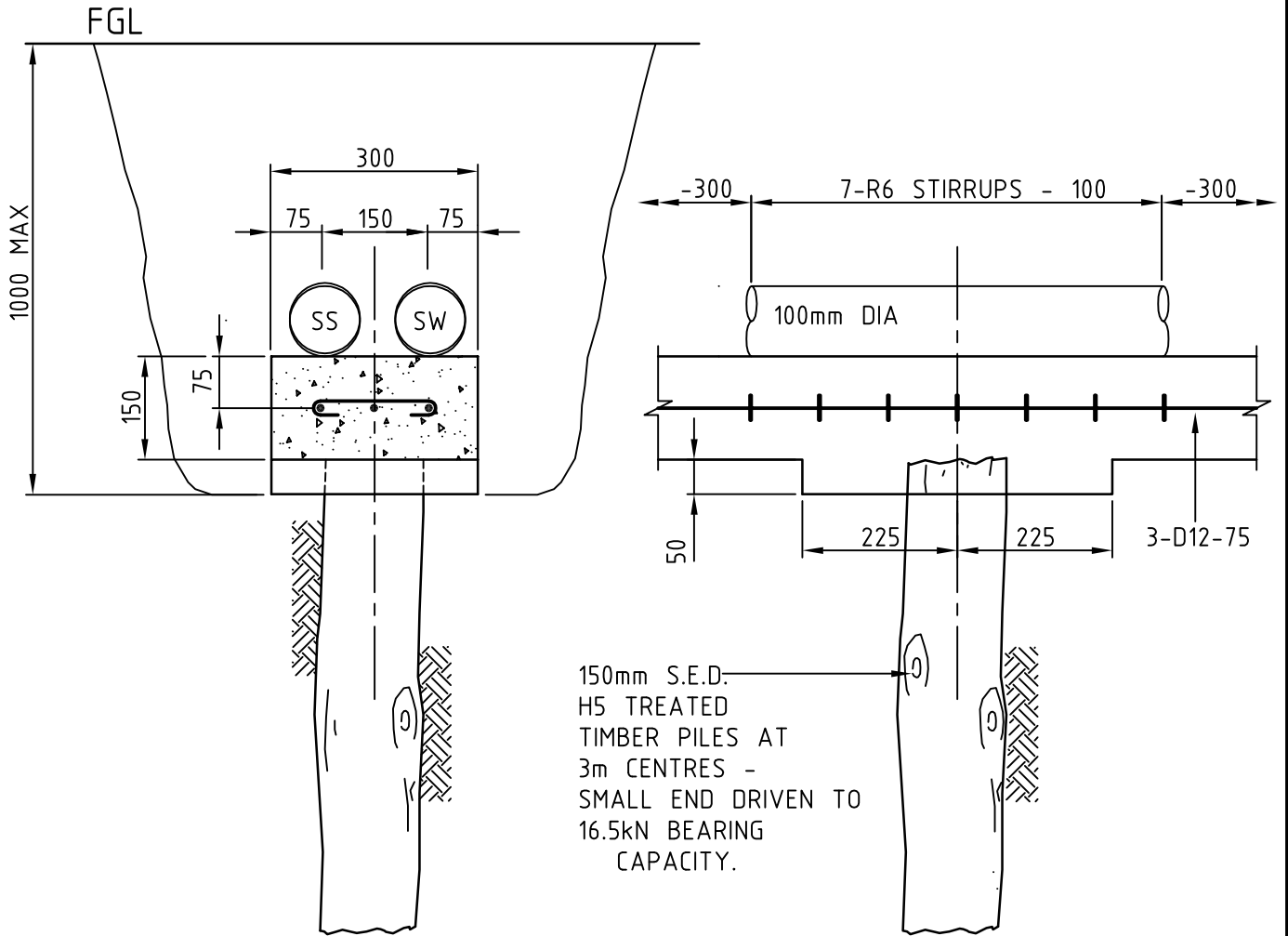

**NELSON
CITY
COUNCIL**

**SERVICES SUPPORT BEAM FOR FILL
SITES**

INFRASTRUCTURE DIVISION

APPROVED

.....
MANAGER INFRASTRUCTURAL ASSETS DATE

PLAN No.

21/213

SHEET 1

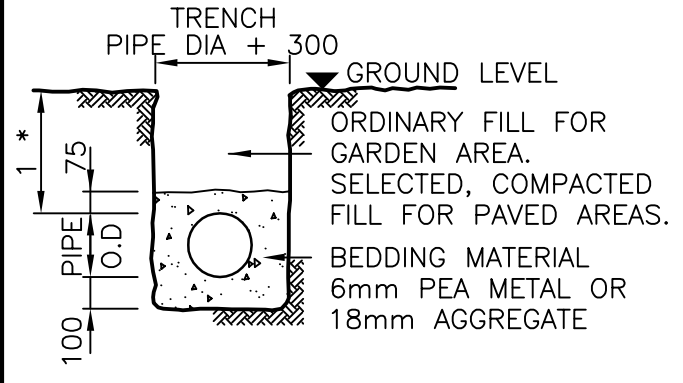
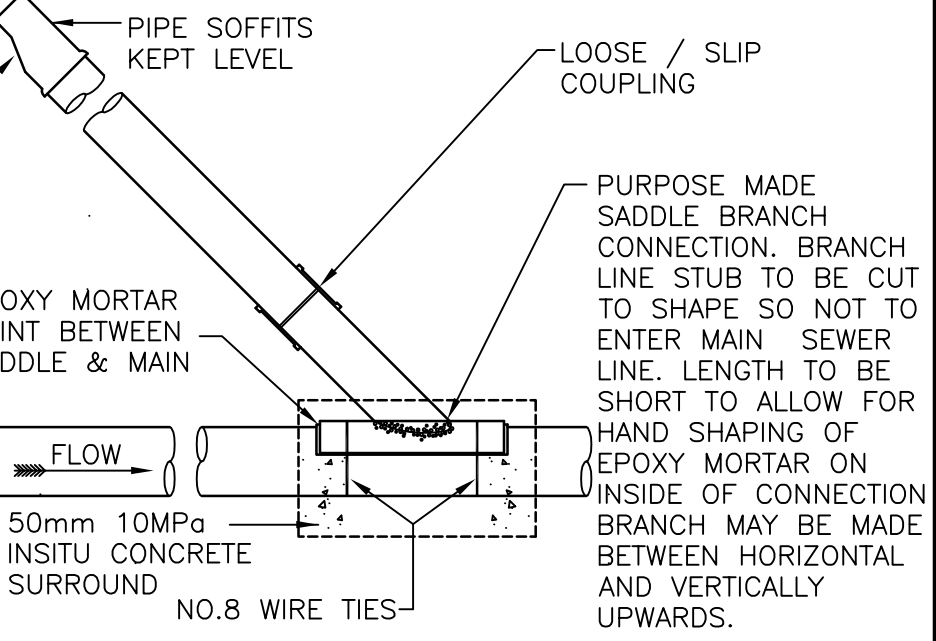
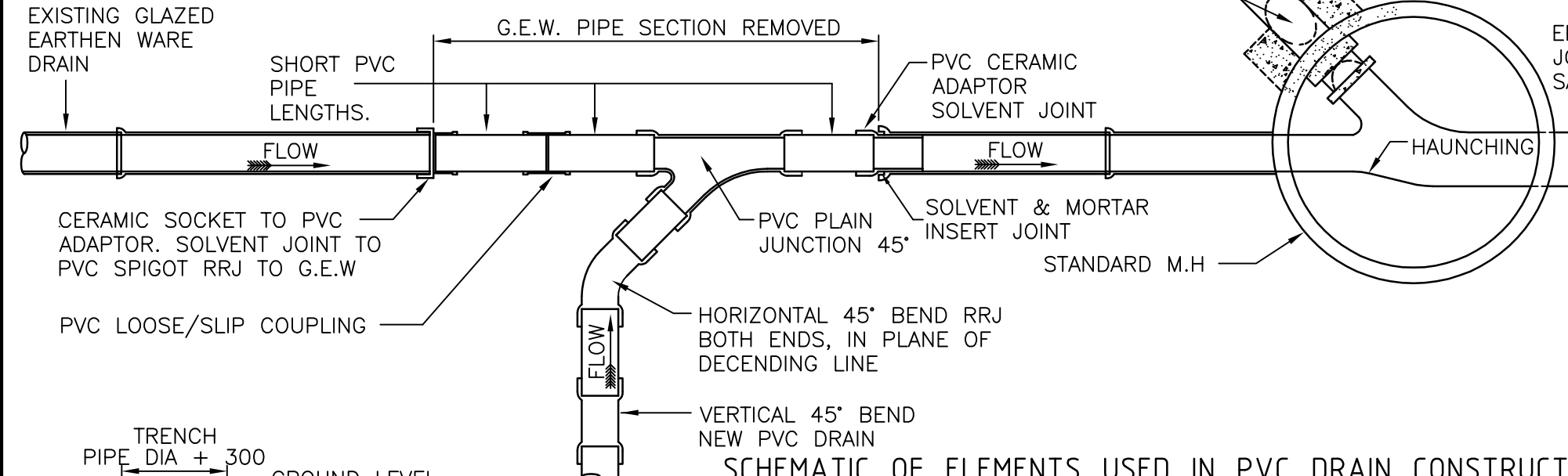
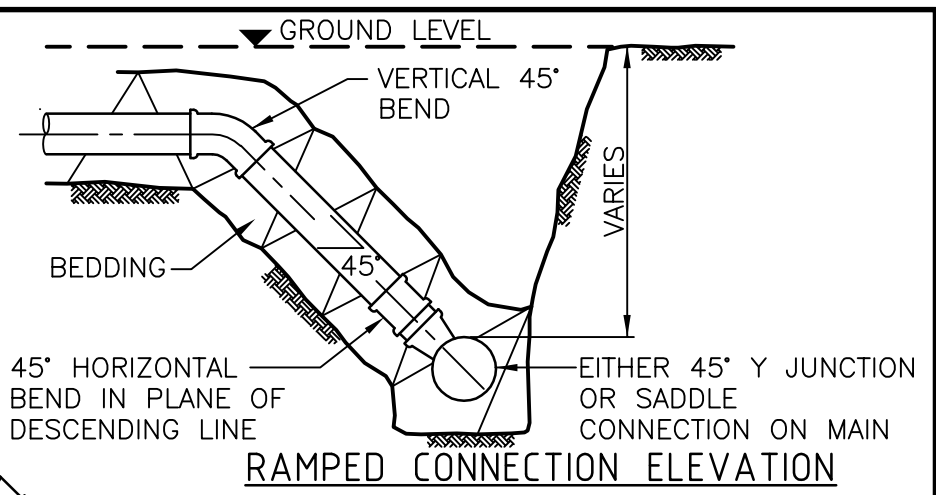
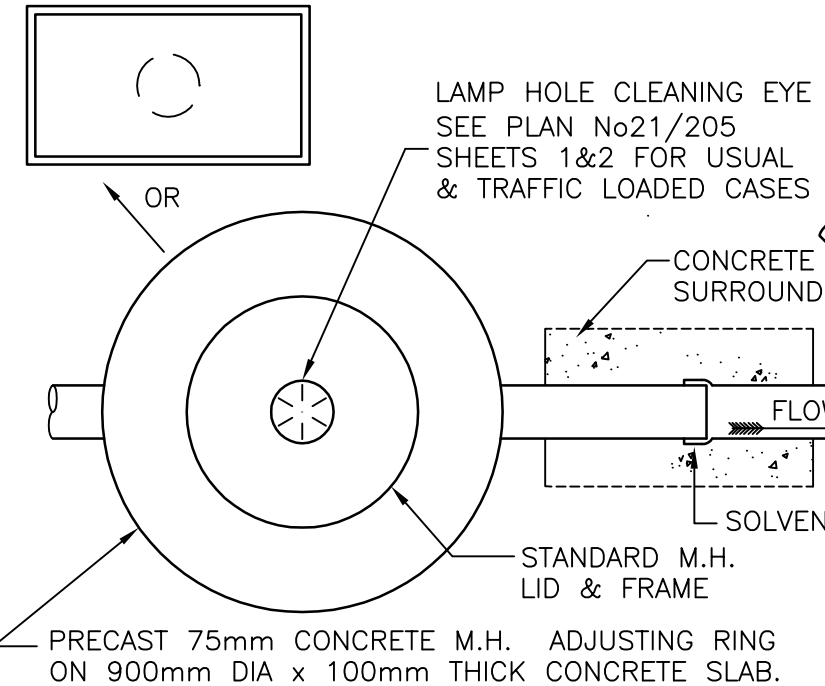
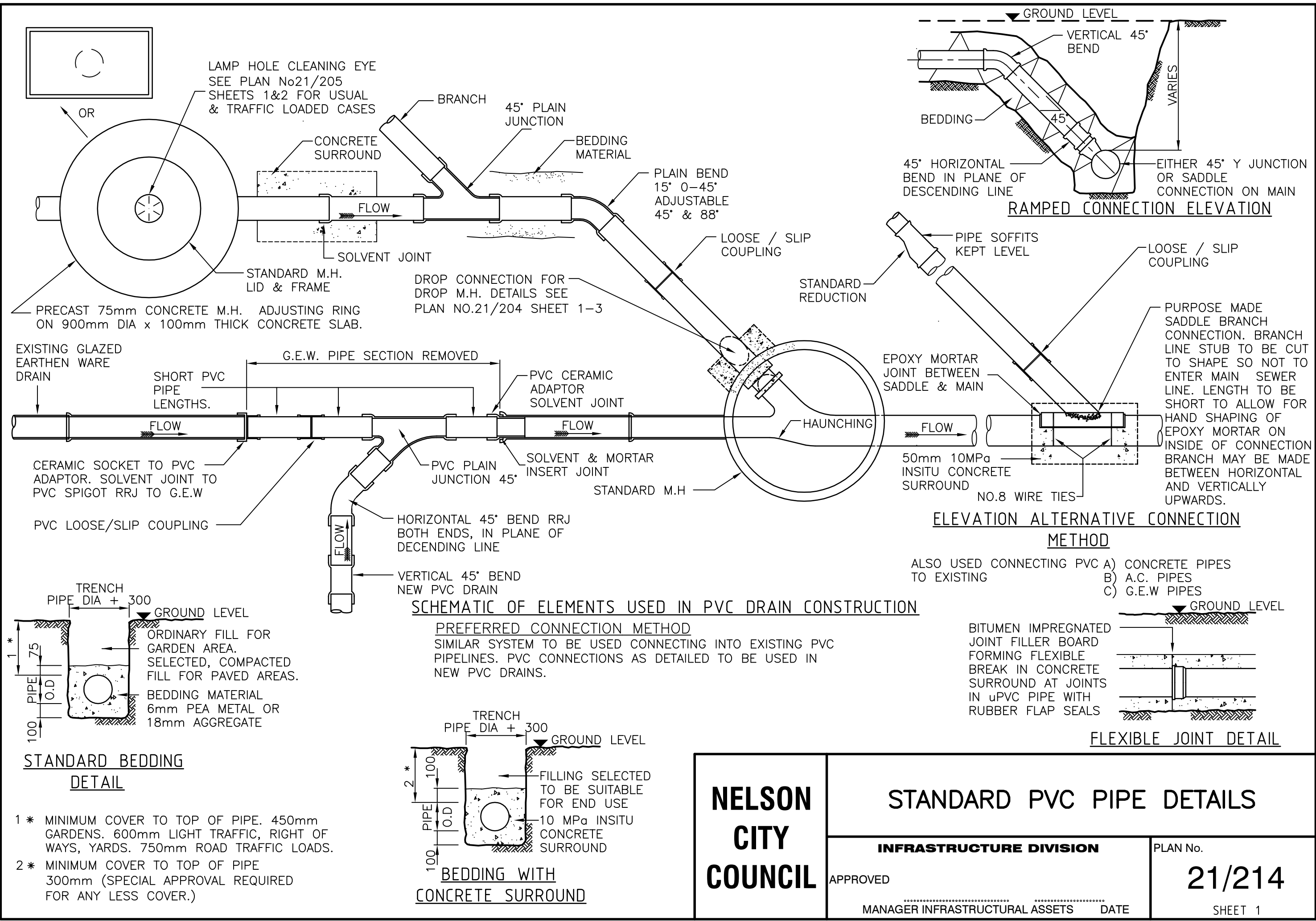

STANDARD BEDDING DETAIL

1 * MINIMUM COVER TO TOP OF PIPE. 450mm GARDENS. 600mm LIGHT TRAFFIC, RIGHT OF WAYS, YARDS. 750mm ROAD TRAFFIC LOADS.

2 * MINIMUM COVER TO TOP OF PIPE 300mm (SPECIAL APPROVAL REQUIRED FOR ANY LESS COVER.)

SCHMATIC OF ELEMENTS USED IN PVC DRAIN CONSTRUCTION

PREFERRED CONNECTION METHOD
SIMILAR SYSTEM TO BE USED CONNECTING INTO EXISTING PVC PIPELINES. PVC CONNECTIONS AS DETAILED TO BE USED IN NEW PVC DRAINS.

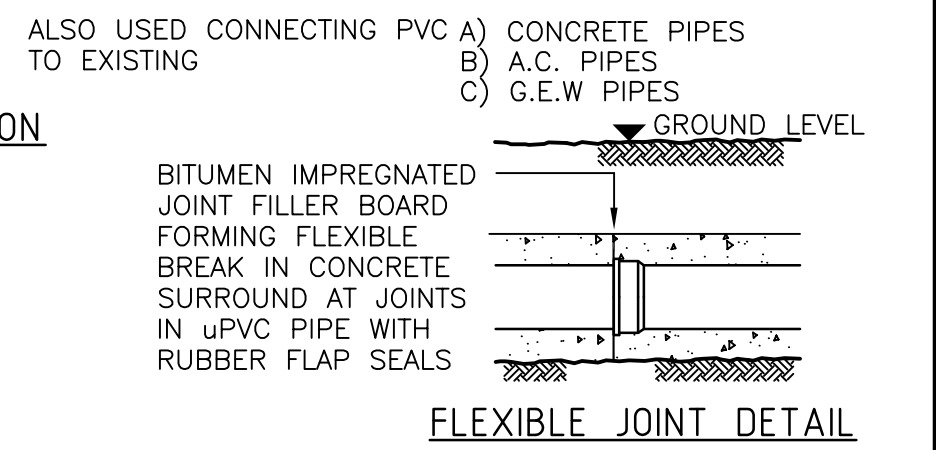
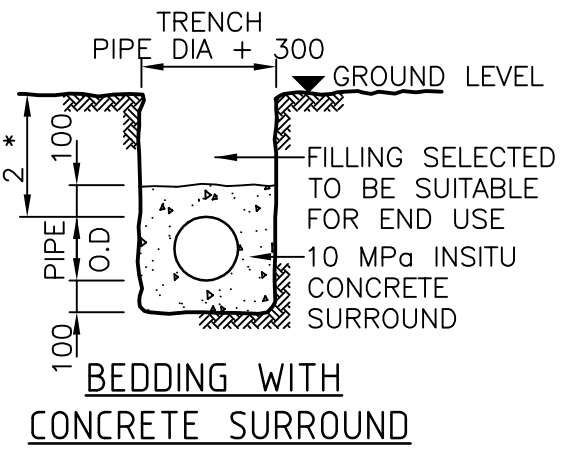

| | | |
|--------------------------------|----------------------------------|---------------|
| NELSON CITY COUNCIL | STANDARD PVC PIPE DETAILS | |
| | INFRASTRUCTURE DIVISION | PLAN No. |
| APPROVED | DATE | 21/214 |
| MANAGER INFRASTRUCTURAL ASSETS | DATE | SHEET 1 |

CUT-IN HOLE FOR CONNECTION TO BE BETWEEN 30° OF TOP AND BOTTOM OF MAIN PIPE

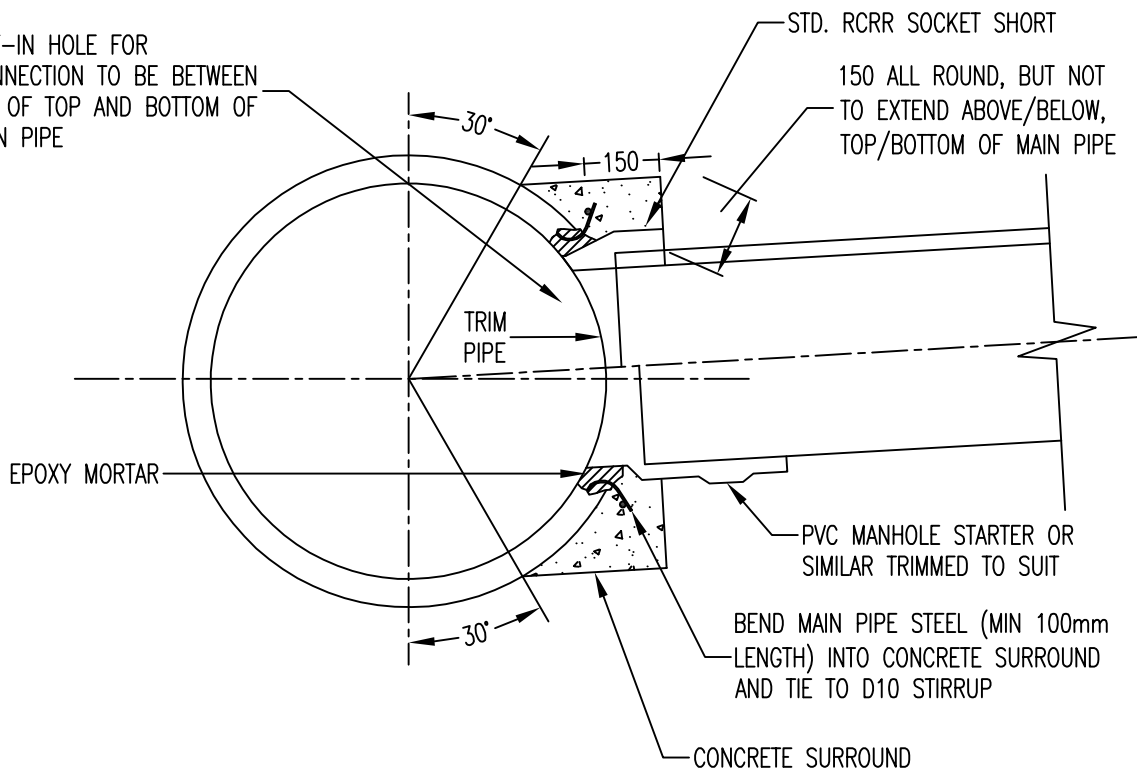

NOTES:

- 1) SPECIAL DESIGN REQUIRED FOR: MAIN PIPES OTHER THAN REINFORCED CONCRETE, MORE THAN ONE CONNECTION PER MAIN.
- 2) DIRECT CONNECTIONS OF THIS TYPE ARE NOT PERMITTED ON PLASTIC MAINS.
- 3) OUTSIDE EDGE OF MAIN PIPE CUT-IN HOLE SHALL BE NOT LESS THAN 300mm FROM COLLAR OR END OF PIPE.
- 4) MAXIMUM DIAMETER OF CUT-IN HOLE SHALL BE LESS THAN TWO THIRDS OF THE INTERNAL DIAMETER OF MAIN PIPE.
- 5) EPOXY MORTAR SHALL BE APPLIED STRICTLY ACCORDING TO THE MANUFACTURER'S RECOMMENDATION AND SHALL BE FULLY CURED BEFORE THE SURROUND IS POURED AND THE SIDELINE LAID.
- 6) MAIN PIPE SURFACE SHALL BE ROUGHENED AND GROUT COATED BEFORE CONCRETE SURROUND IS POURED.
- 7) DIRECT CONNECTIONS MUST BE APPROVED BY THE ENGINEER, AND NORMALLY SHALL ONLY BE USED WHERE THE SIDE LINE IS LESS THAN 10m LONG, AND ACCESS FOR CLEANING THE SIDELINE IS EASILY OBTAINABLE AT THE UPSTREAM END. THAT IS THE SIDELINE SHALL TERMINATE WITH A MANHOLE, LHCE OR SUMP.
- 8) DIAMETER OF SIDELINE PIPE SHALL BE LESS THAN HALF THE INTERNAL DIAMETER OF THE MAIN PIPE.

SQUARE RADIAL DIRECT CONNECTIONS:

| NOMINAL SIDELINE DIAMETER | MINIMUM MAIN PIPE DIAMETER |
|---------------------------|----------------------------|
| 100 | 225 |
| 150 | 375 |
| 200 | 450 |
| 225/250 | 525 |
| 300 | 675 |
| 375 | 825 |
| 450 | 975 |
| 525 | 1050 |
| 600/675 | 1350 |
| 750 | 1600 |
| 825/900 | 1800 |
| 975 | 1950 |
| 1050 | 2100 |

**NELSON
CITY
COUNCIL**

**DIRECT CONNECTIONS
TO STORMWATER PIPES**

INFRASTRUCTURE DIVISION

APPROVED

.....
MANAGER INFRASTRUCTURAL ASSETS DATE

PLAN No.

21/215

SHEET 1

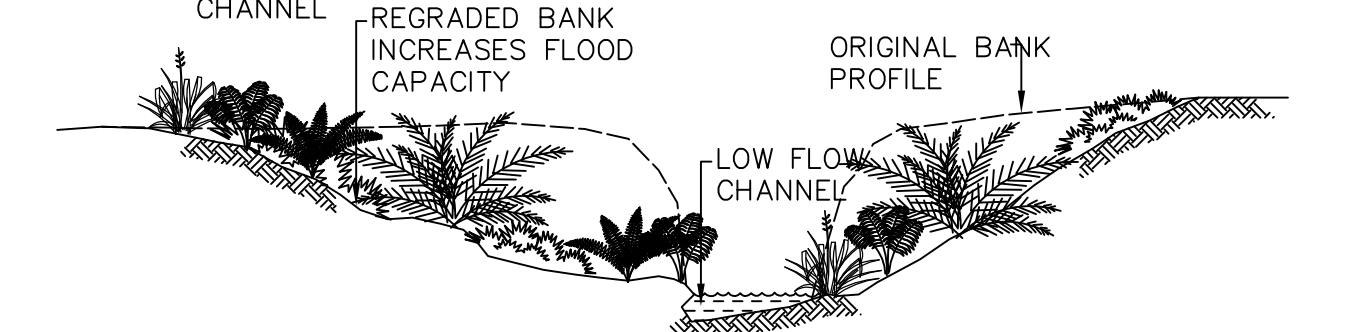
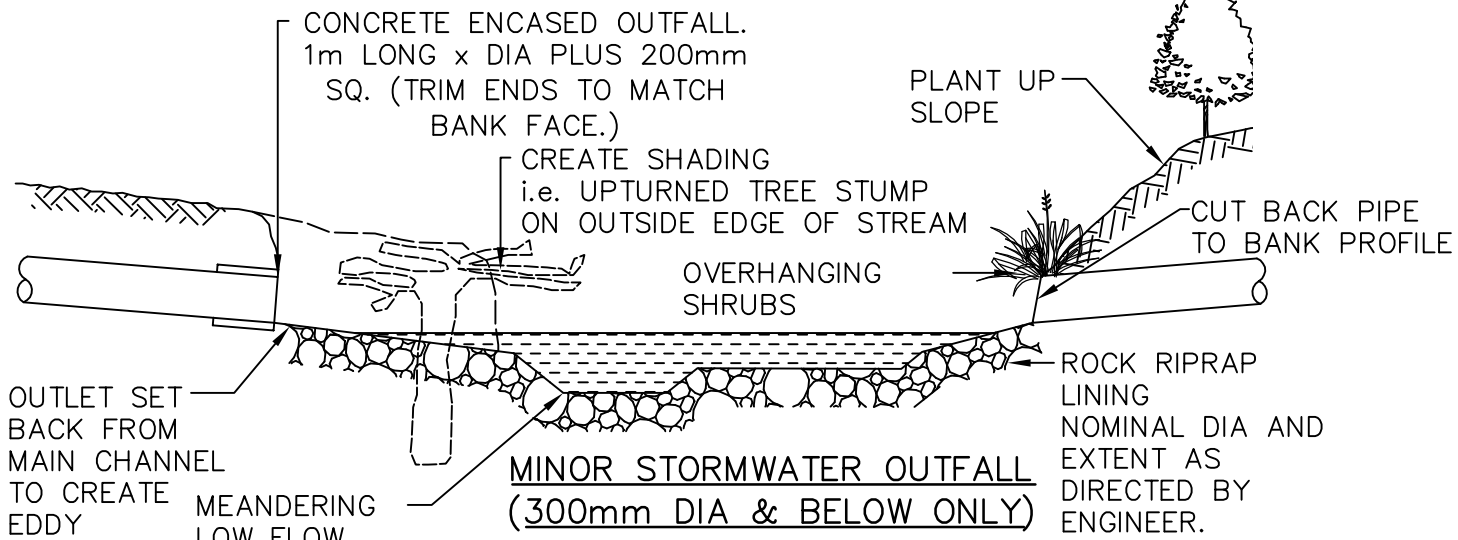

GENTLY SLOPING BANKS WILL BECOME INUNDATED DURING FLOOD FLOWS, ENABLING THE DISSIPATION OF FLOW ENERGY THAT WOULD OTHERWISE CONTRIBUTE TO CHANNEL DAMAGE. ENSURE FLOOD WATERWAY CAPACITY IS MAINTAINED WHERE THERE IS HEAVY VEGETATION.

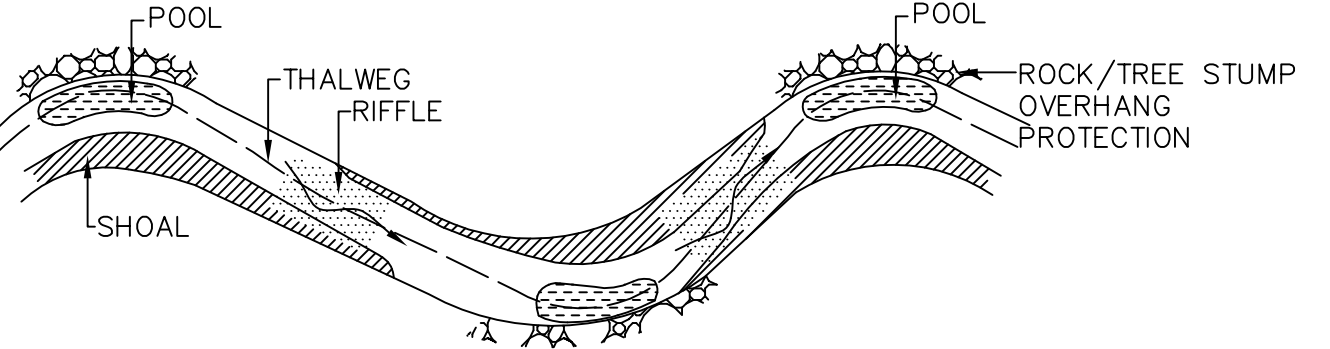

WATERWAY MEANDER

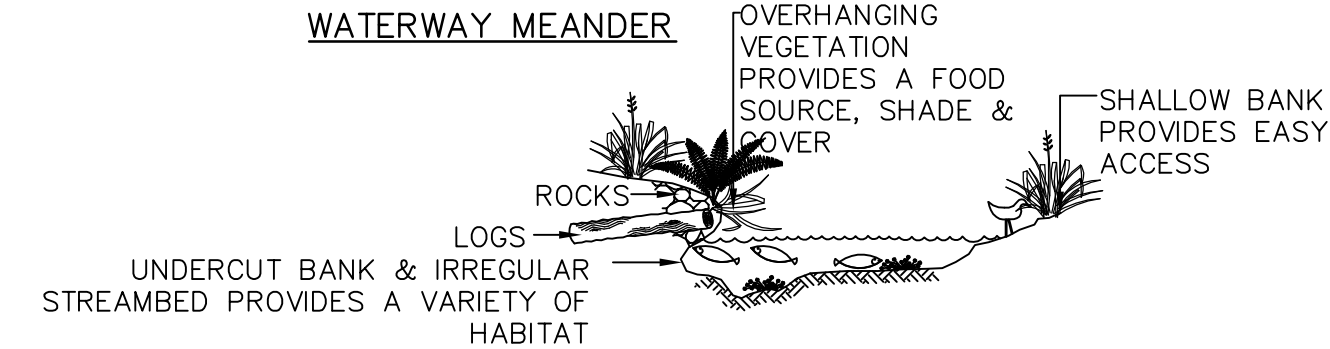

**NELSON
CITY
COUNCIL**

**OUTFALL DETAILS & DRAINAGE
WATERWAY CONCEPTS**

INFRASTRUCTURE DIVISION

APPROVED

MANAGER INFRASTRUCTURAL ASSETS DATE

PLAN No.

21/216

SHEET 1

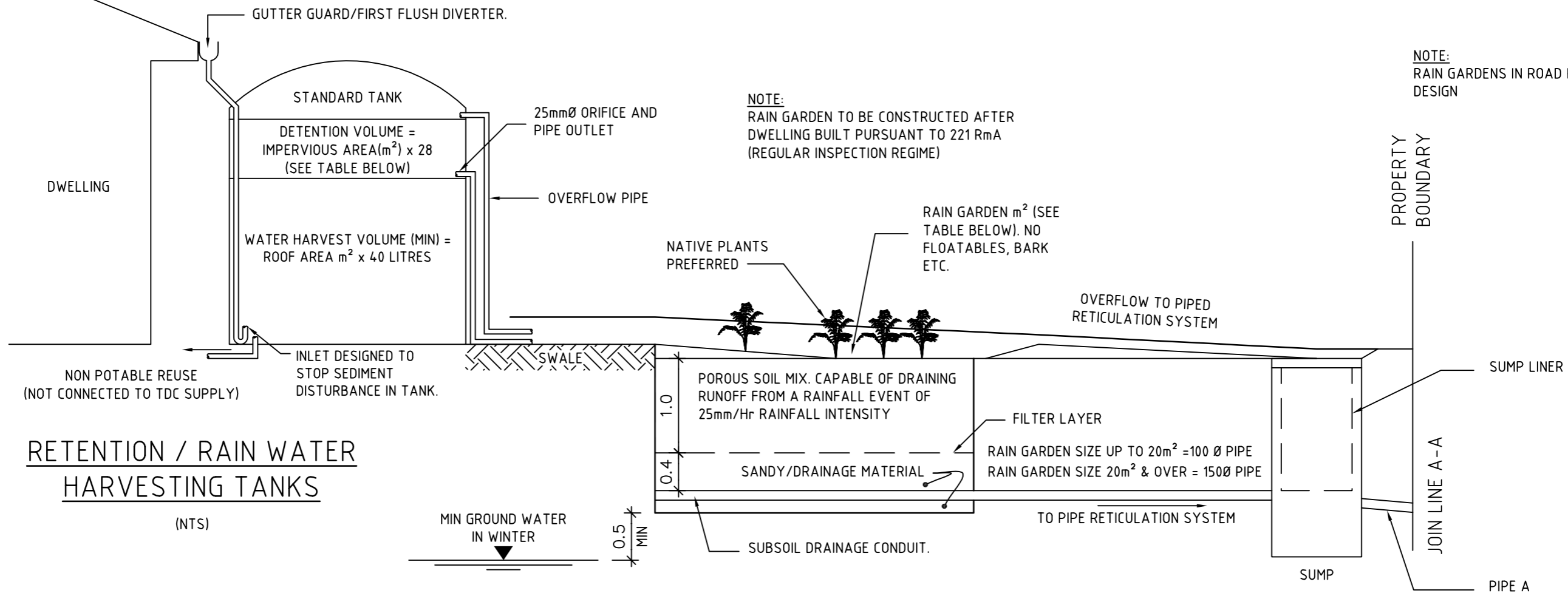

RETENTION / RAIN WATER HARVESTING TANKS

(NTS)

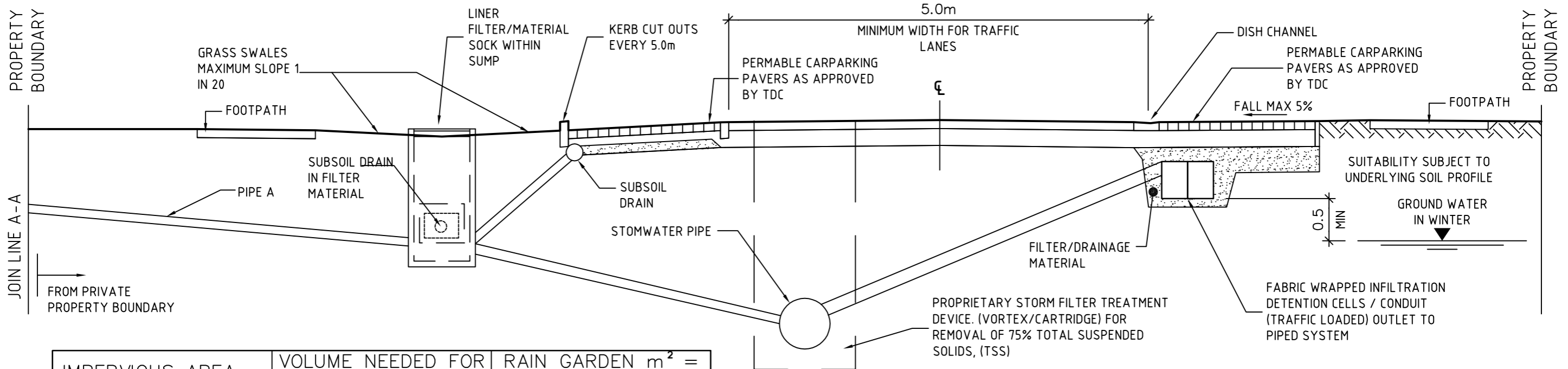

| IMPERVIOUS AREA = ROOF + PAVED AREA | VOLUME NEEDED FOR STORMWATER RETENTION | RAIN GARDEN m ² = 8% OF IMPERVIOUS SURFACE |
|-------------------------------------|--|---|
| 150m ² | 4200 LITRES | 12m ² |
| 200m ² | 5600 LITRES | 16m ² |
| 250m ² | 7000 LITRES | 20m ² |
| 300m ² | 8400 LITRES | 25m ² |
| 350m ² | 9800 LITRES | 30m ² |
| 400m ² | 11200 LITRES | 35m ² |
| 500m ² | 14000 LITRES | 40m ² |

NELSON CITY COUNCIL

LOW IMPACT DESIGN CONCEPTS (SPECIFIC DESIGN REQUIRED)

APPROVED

.....

MANAGER INFRASTRUCTURAL ASSETS DATE

PLAN No.

21/217

SHEET 1

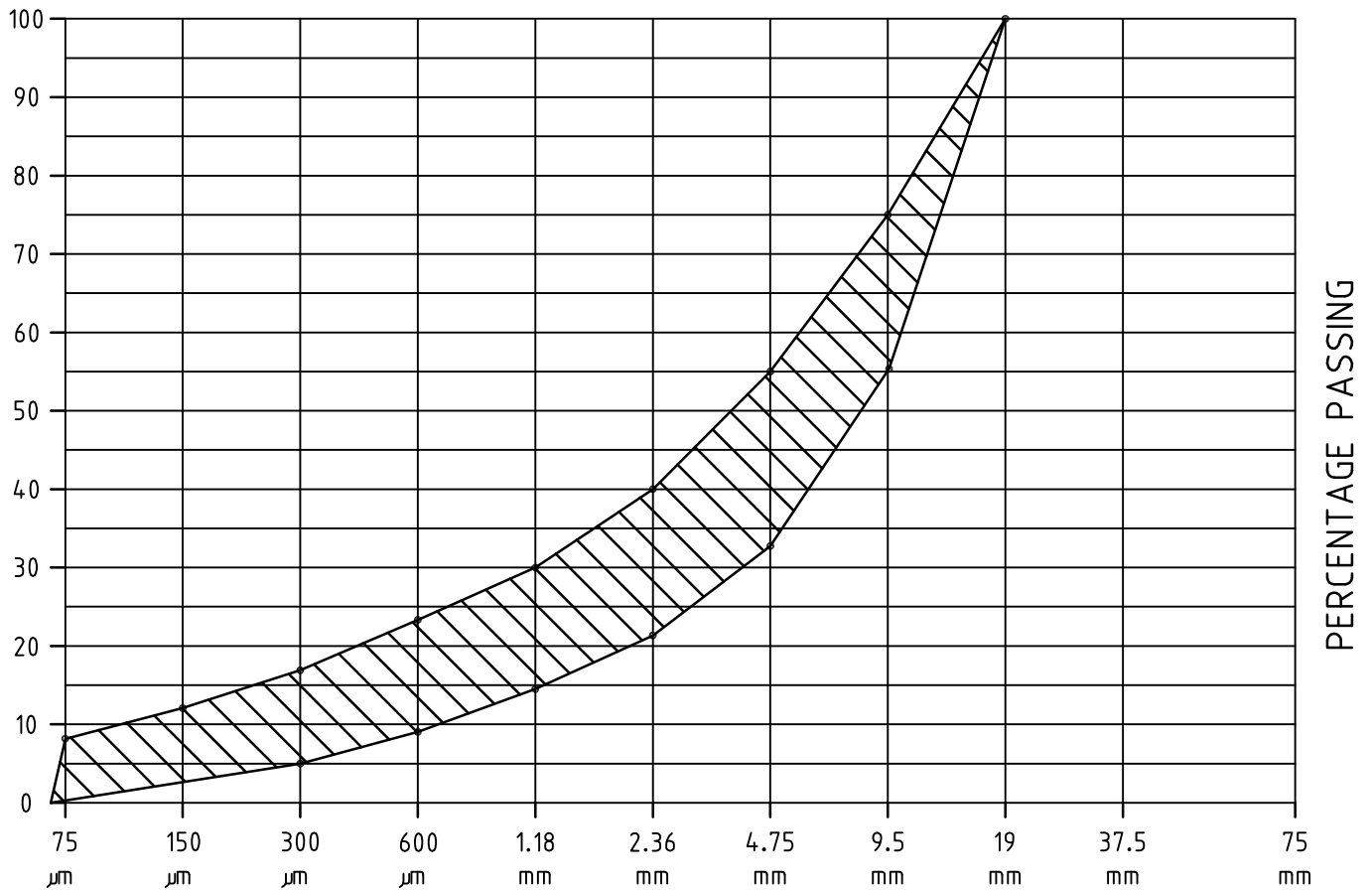

STANDARD SQUARE SIEVE OPENING
GRADING DISTRIBUTION CURVE
 (TNZ M/4 : 1995 GRADING LIMITS)

A. PROPORTION OF BROKEN ROCK:

THE PERCENTAGE BY WEIGHT OF MATERIAL IN EACH OF THE FRACTIONS BETWEEN THE 19mm AND 4.75mm SIEVES HAVING TWO OR MORE BROKEN FACES SHALL NOT BE LESS THAN 70%

B. CRUSHING RESISTANCE:

THE CRUSHING RESISTANCE SHALL NOT BE LESS THAN
 130kN

C. WEATHERING RESISTANCE:

THE AGGREGATE SHALL FALL INTO ONE OF THE FOLLOWING WEATHERING RESISTANCE CATEGORIES:- AA AB AC BA BB CA.

D. SAND EQUIVALENT:

THE SAND EQUIVALENT SHALL NOT BE LESS THAN 40 WHEN THE AGGREGATE IS TESTED ACCORDING TO NZS 4407: 1991.

**NELSON
 CITY
 COUNCIL**

20mm BASECOURSE AGGREGATE

ASSET MANAGEMENT DIVISION

APPROVED

MANAGER INFRASTRUCTURAL ASSETS

Jan. 2003

DATE

PLAN No.

21/300

SHEET 1

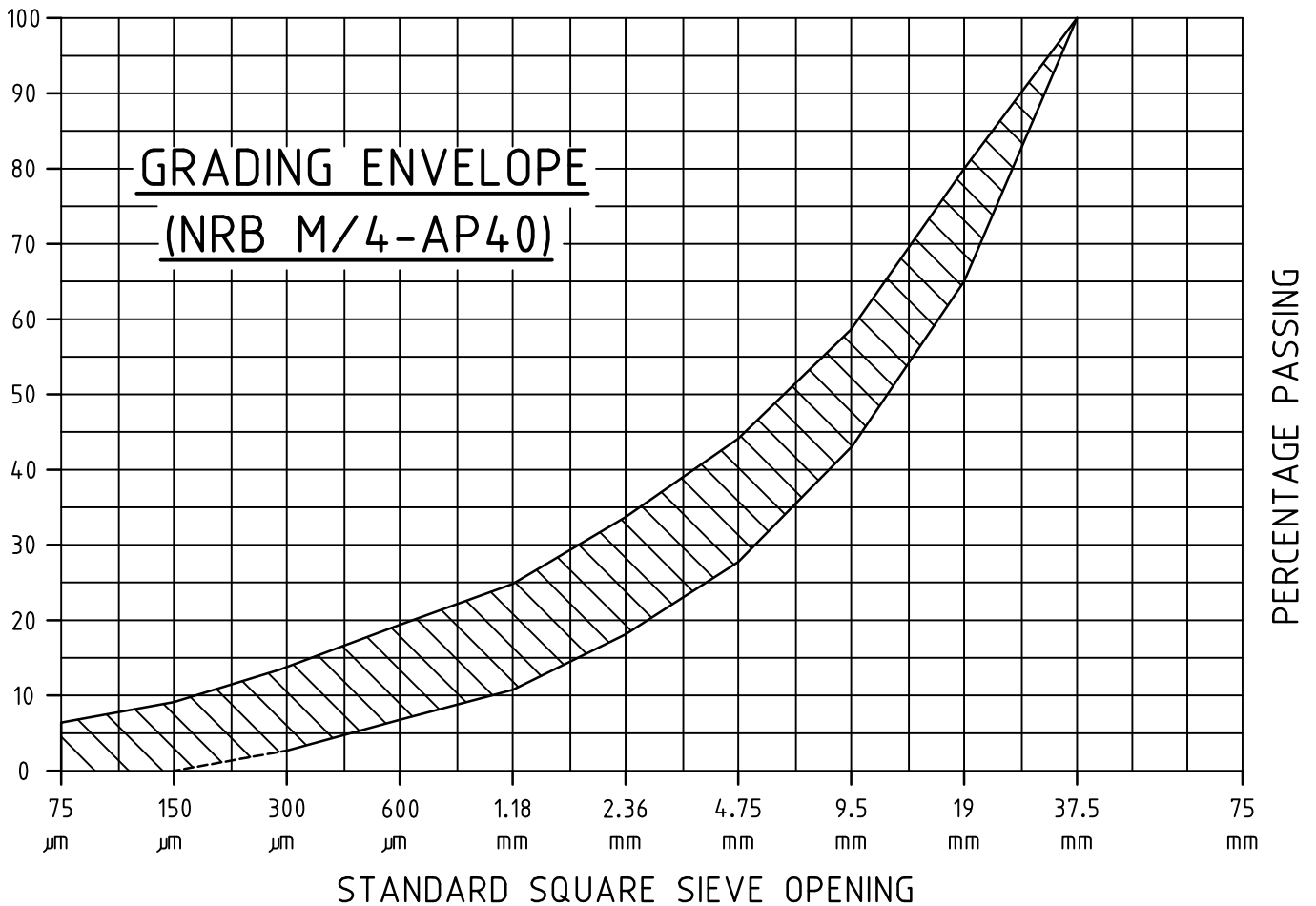

A. PROPORTION OF BROKEN ROCK:

THE PERCENTAGE BY WEIGHT OF MATERIAL IN EACH OF THE FOUR FRACTIONS BETWEEN THE 37.5mm AND 4.5mm SIEVES HAVING TWO OR MORE BROKEN FACES SHALL NOT BE LESS THAN 70%

B. CRUSHING RESISTANCE:

THE CRUSHING RESISTANCE SHALL NOT BE LESS THAN 130kN

C. WEATHERING RESISTANCE:

THE AGGREGATE SHALL FALL INTO ONE OF THE FOLLOWING WEATHERING RESISTANCE CATEGORIES:- AA AB AC BA BB CA.

D. SAND EQUIVALENT:

THE SAND EQUIVALENT SHALL NOT BE LESS THAN 40 WHEN THE AGGREGATE IS TESTED ACCORDING TO NZS 4407: 1991.

**NELSON
CITY
COUNCIL**

40mm BASECOURSE AGGREGATE

ASSET MANAGEMENT DIVISION

APPROVED

MANAGER INFRASTRUCTURAL ASSETS

Jan. 2003

DATE

PLAN No.

21/300

SHEET 2

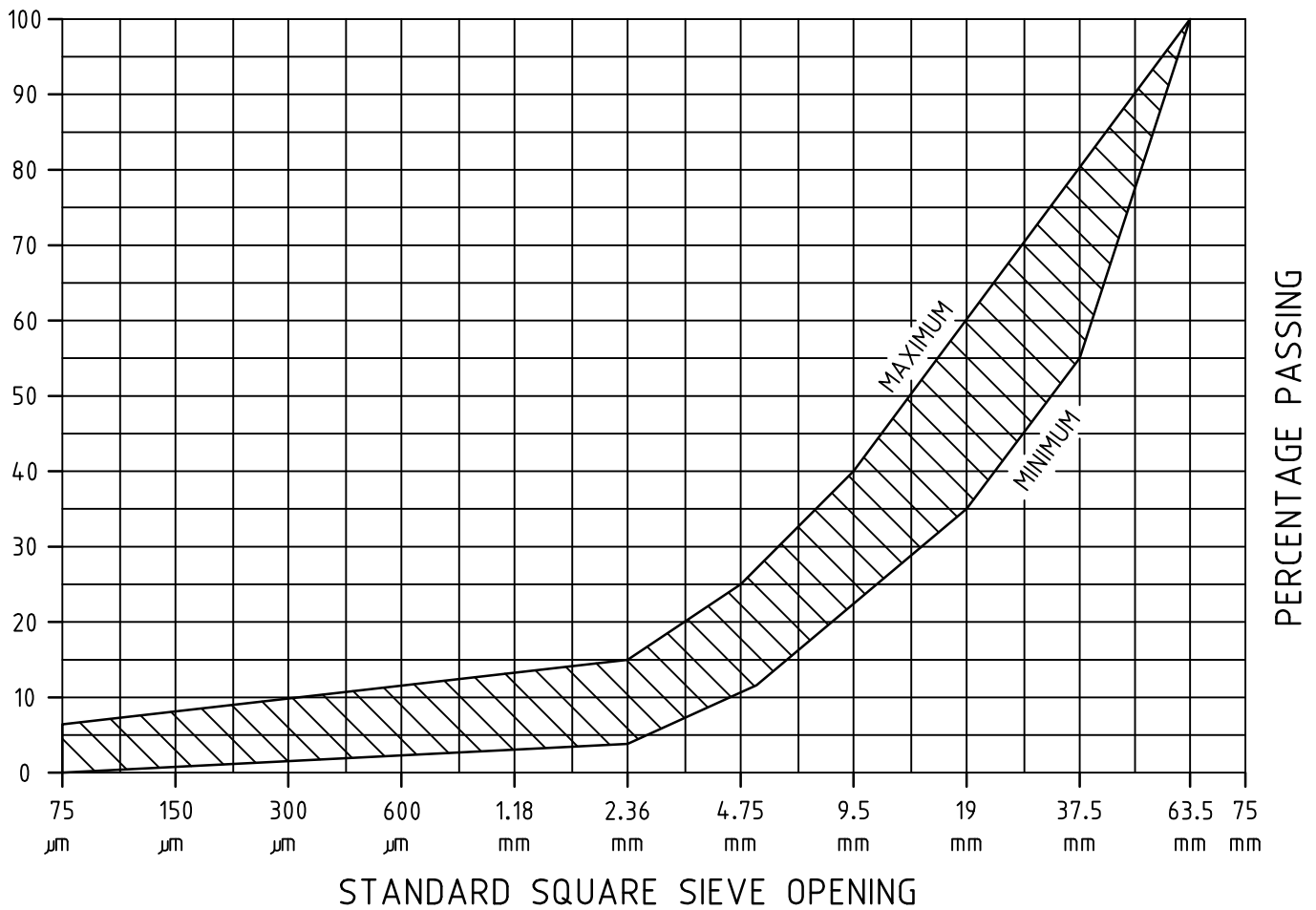

A. PROPORTION OF BROKEN ROCK:

THE PERCENTAGE BY WEIGHT OF MATERIAL IN EACH OF THE FOUR FRACTIONS BETWEEN THE 37.5mm AND 4.5mm SIEVES HAVING TWO OR MORE BROKEN FACES SHALL NOT BE LESS THAN 70%

B. CRUSHING RESISTANCE:

THE CRUSHING RESISTANCE SHALL NOT BE LESS THAN 110kN

C. WEATHERING RESISTANCE:

THE AGGREGATE SHALL FALL INTO ONE OF THE FOLLOWING WEATHERING RESISTANCE CATEGORIES:- AA AB AC BA BB CA.

D. SAND EQUIVALENT:

THE SAND EQUIVALENT SHALL NOT BE LESS THAN 40 WHEN THE AGGREGATE IS TESTED ACCORDING TO NZS 4407: 1991.

**NELSON
CITY
COUNCIL**

**65mm SUB-BASECOURSE
AGGREGATE**

ASSET MANAGEMENT DIVISION

APPROVED

MANAGER INFRASTRUCTURAL ASSETS

Jan. 2003

DATE

PLAN No.

21/300

SHEET 3

EXAMPLE: (SHOWN IN DOTTED LINE)

RESIDENTIAL ROAD

OBSERVED DEFLECTIONS 3.6mm EXTRA DEPTH OF METALCOURSE REQUIRED = 210mm

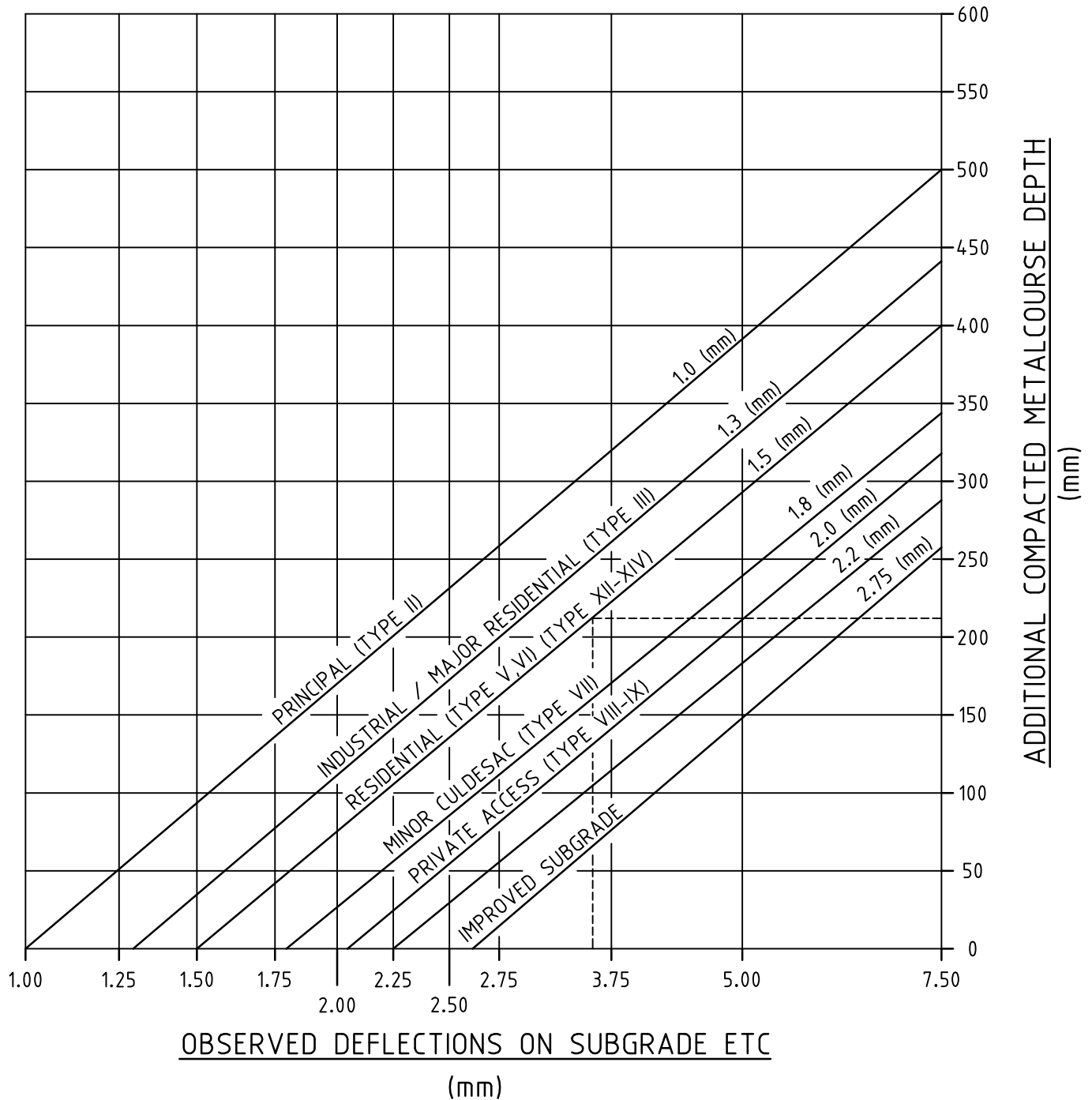

**NELSON
CITY
COUNCIL**

DESIGN GRAPH FOR FLEXIBLE PAVEMENTS BENKLEMAN BEAM DEFLECTIONS

ASSET MANAGEMENT DIVISION

APPROVED

MANAGER INFRASTRUCTURAL ASSETS

Jan. 2003

DATE

PLAN No.

21/301

SHEET 1

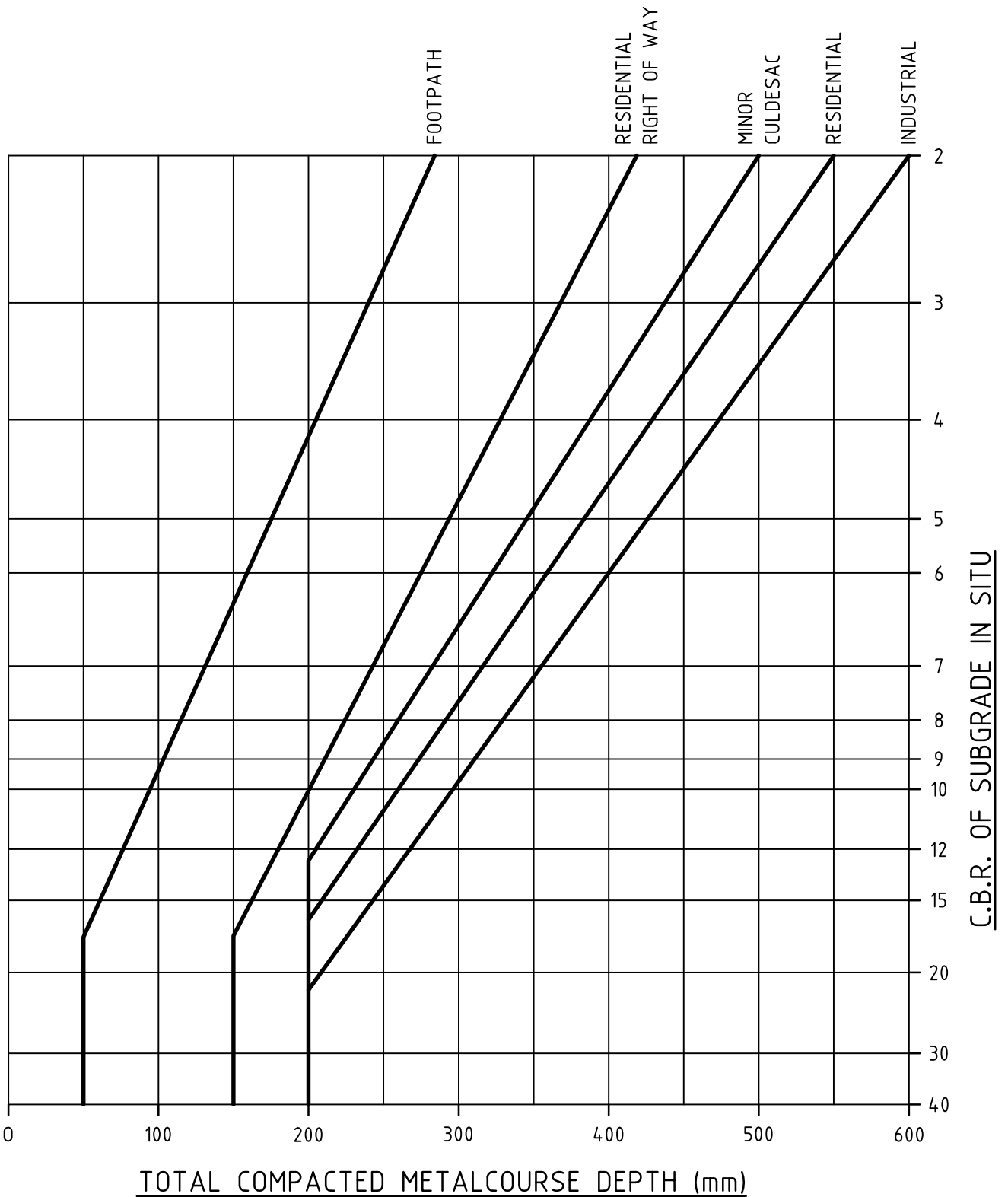

**NELSON
CITY
COUNCIL**

**DESIGN GRAPH FOR FLEXIBLE
PAVEMENTS
CBR METHOD**

ASSET MANAGEMENT DIVISION

APPROVED

MANAGER INFRASTRUCTURAL ASSETS

Jan. 2003

DATE

PLAN No.

21/301

SHEET 2

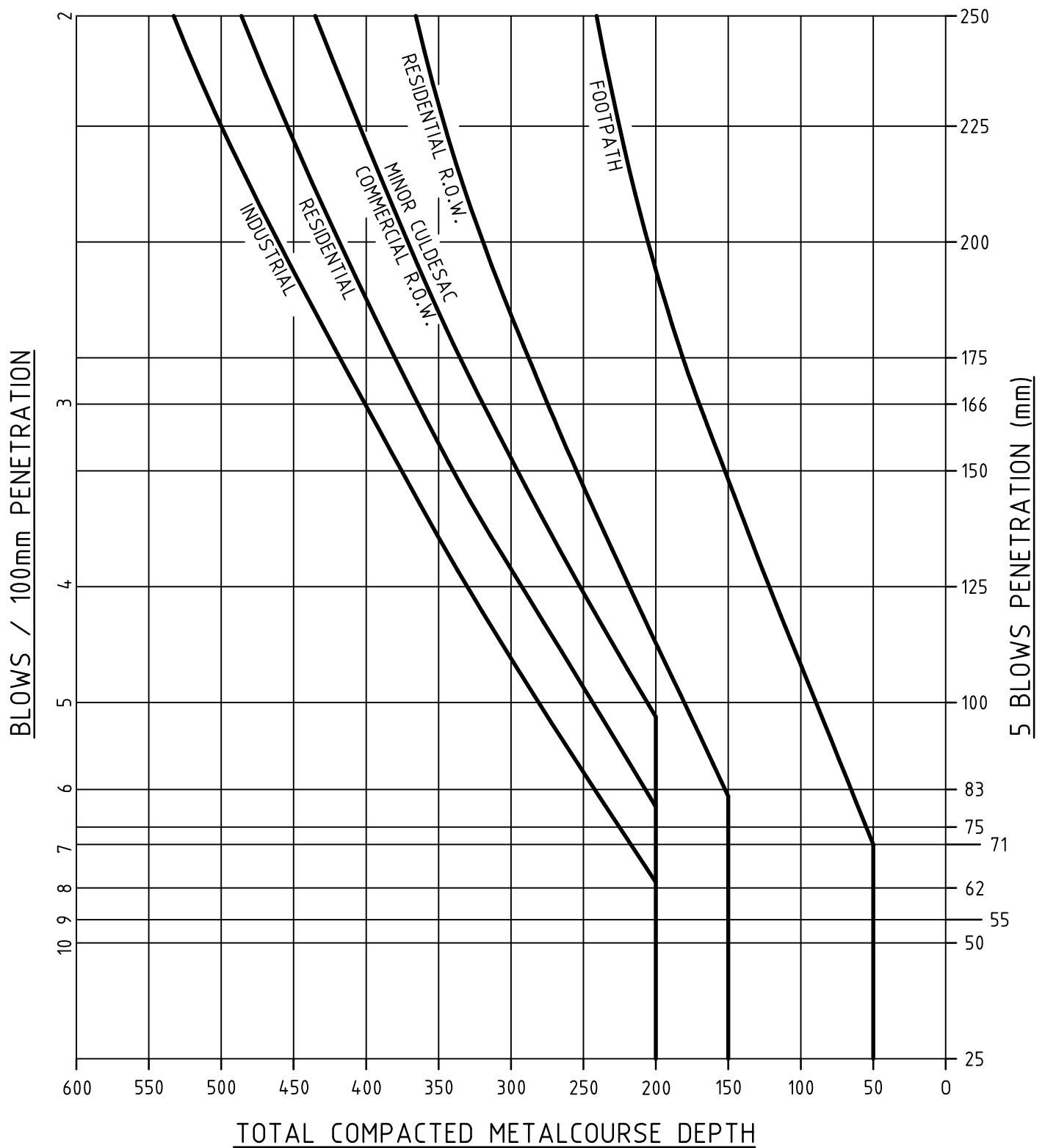

**NELSON
CITY
COUNCIL**

**DESIGN GRAPH FOR FLEXIBLE PAVEMENTS
SCALA DYNAMIC CONE PENETROMETER**

ASSET MANAGEMENT DIVISION

APPROVED

MANAGER INFRASTRUCTURAL ASSETS

Jan. 2003

DATE

PLAN No.

21/301

SHEET 3

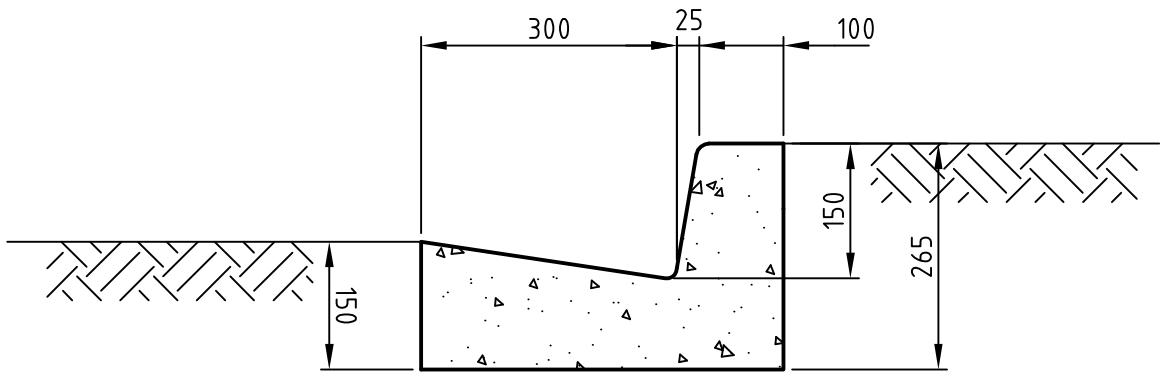

KERB & CHANNEL

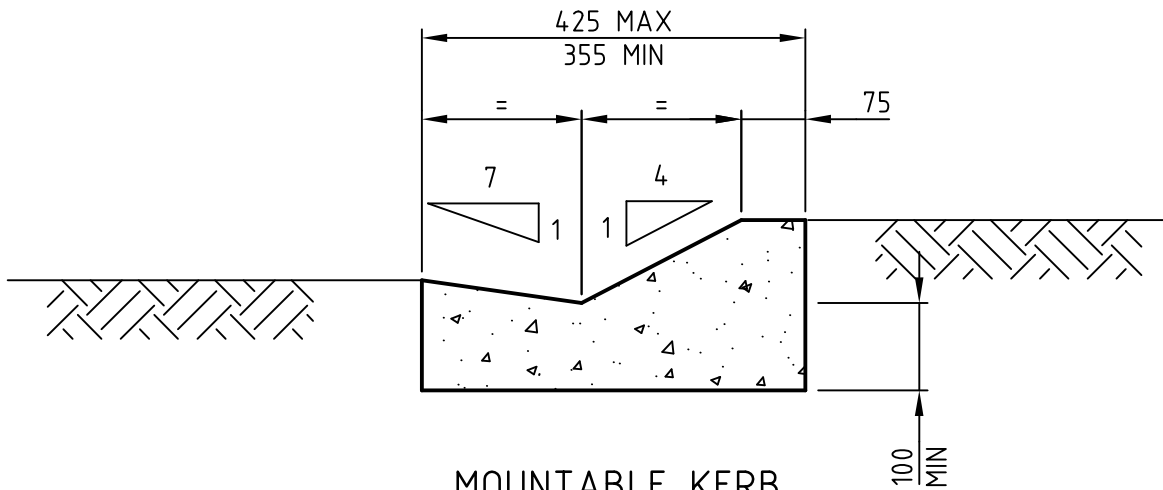

MOUNTABLE KERB
& CHANNEL

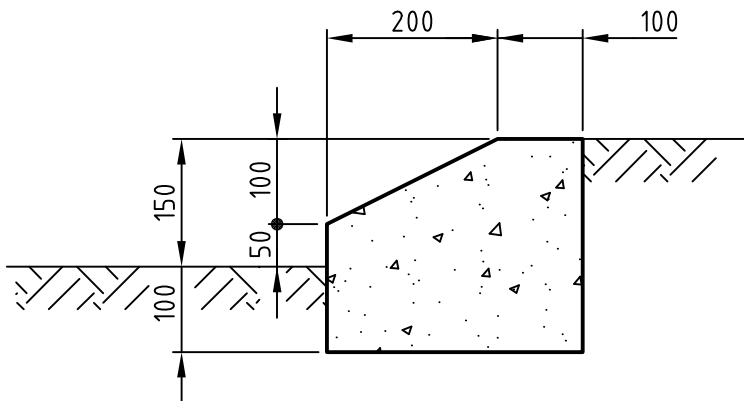

MOUNTABLE KERB

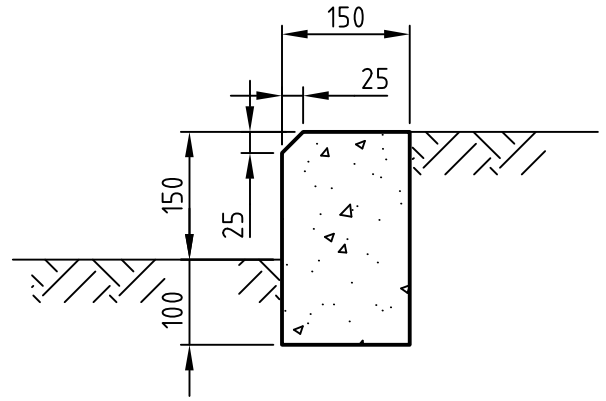

UNMOUNTABLE KERB

**NELSON
CITY
COUNCIL**

**STANDARD DETAILS KERB &
CHANNEL PROFILES**

ASSET MANAGEMENT DIVISION

APPROVED

MANAGER INFRASTRUCTURAL ASSETS

Jan. 2003

DATE

PLAN No.

21/302

SHEET 1

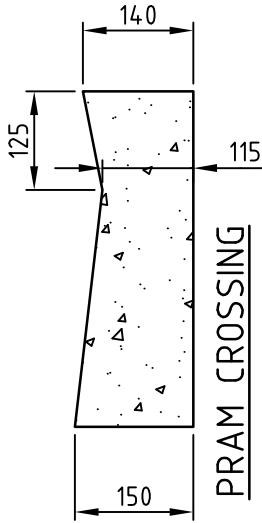

PRAM CROSSING

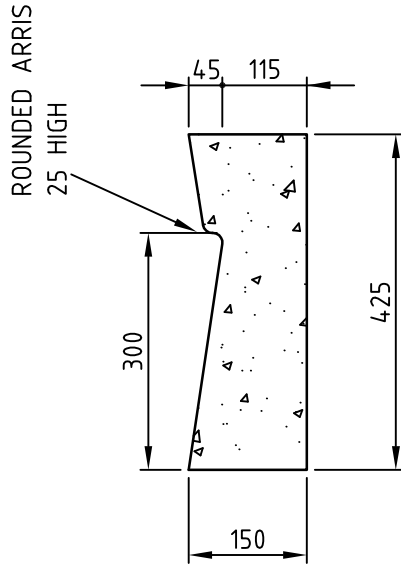

MOUNTABLE KERB CROSSING

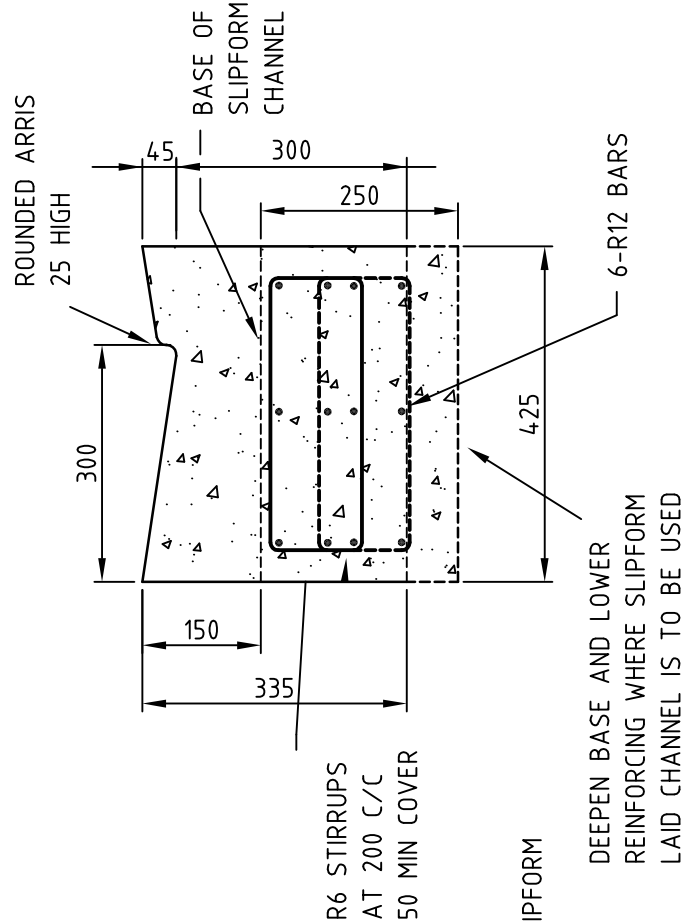

R6 STIRRUPS
AT 200 C/C
50 MIN COVER

DEEPEN BASE AND LOWER
REINFORCING WHERE SLIPFORM
LAID CHANNEL IS TO BE USED

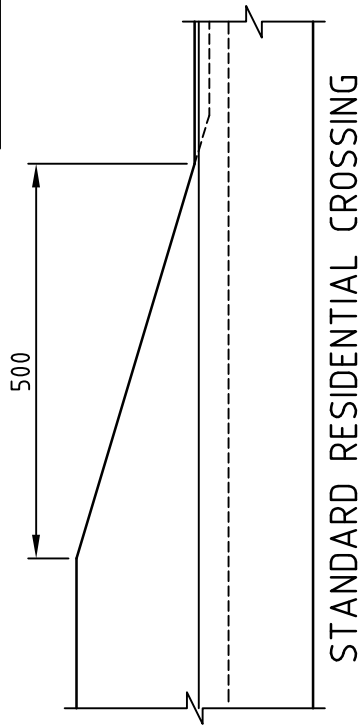

STANDARD RESIDENTIAL CROSSING

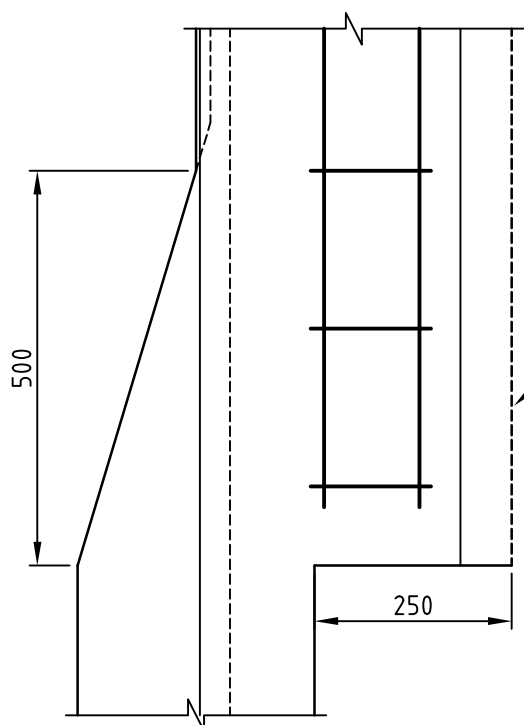

INCREASE DEPTH
AT CROSSING

CONCRETE STRENGTH AT 28 DAYS = 28MPa

STANDARD INDUSTRIAL CROSSING

**NELSON
CITY
COUNCIL**

**STANDARD DETAILS
KERB & CHANNEL CROSSINGS**

ASSET MANAGEMENT DIVISION

APPROVED

MANAGER INFRASTRUCTURAL ASSETS

Jan. 2003

DATE

PLAN No.

21/303

SHEET 1

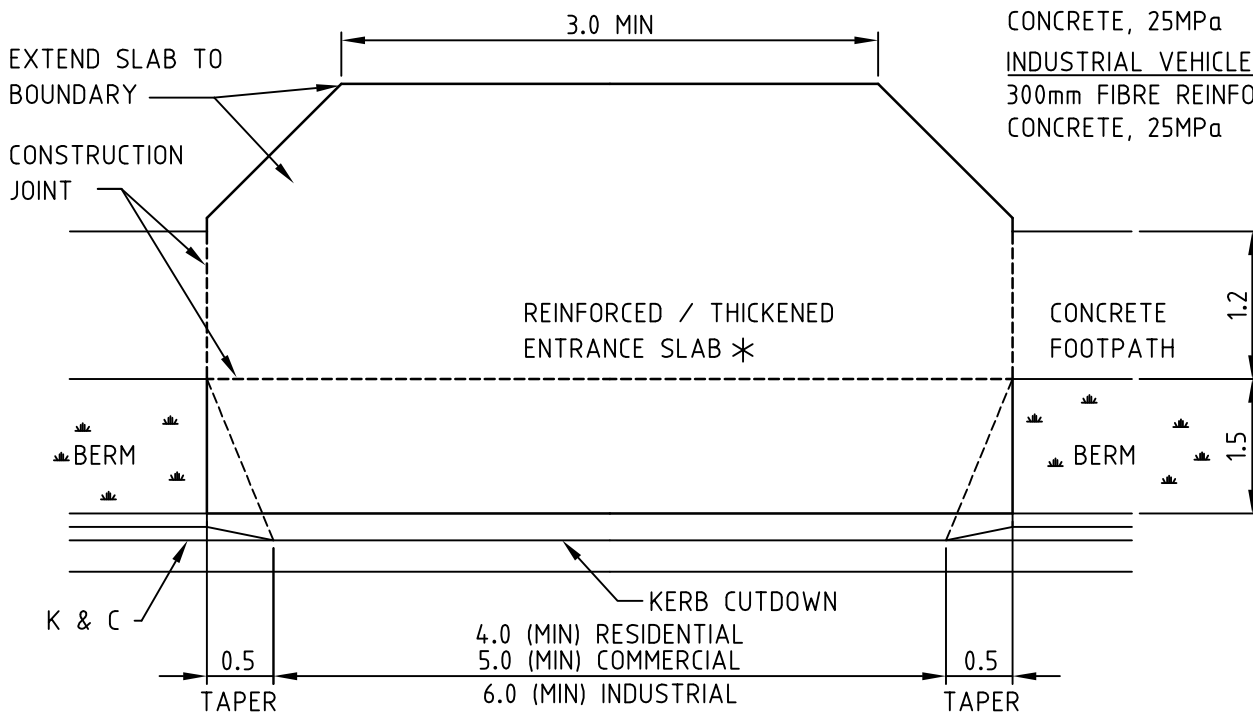
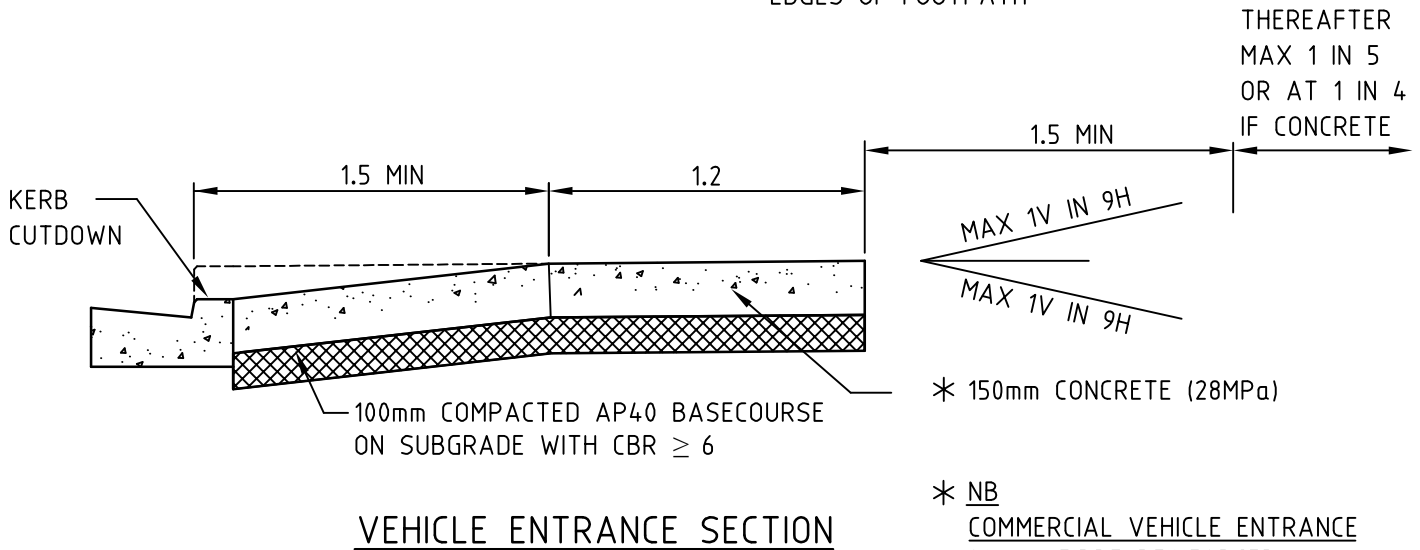
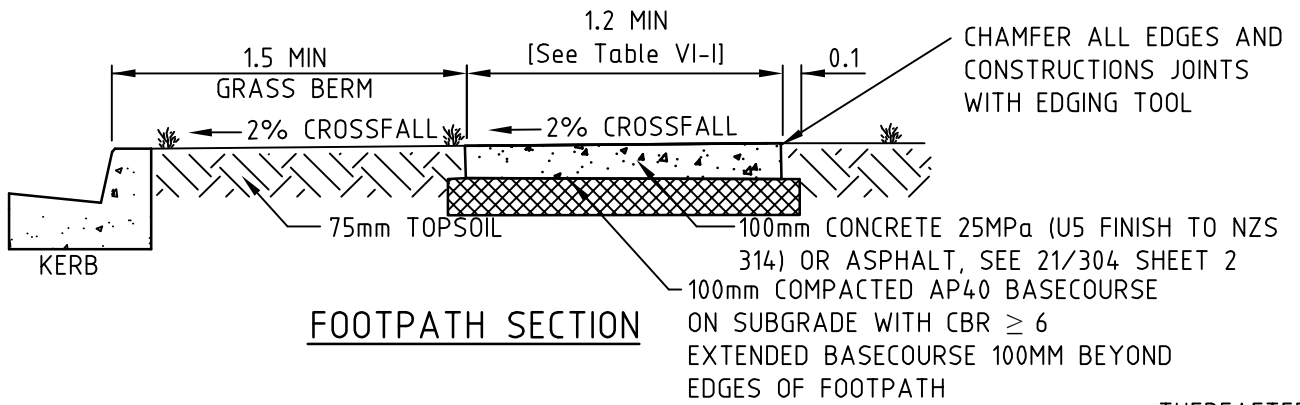

**NELSON
CITY
COUNCIL**

**FOOTPATH
OFFSET FROM KERB**

ASSET MANAGEMENT DIVISION

APPROVED

MANAGER INFRASTRUCTURAL ASSETS

Feb. 2006

DATE

PLAN No.

21/304

SHEET 1

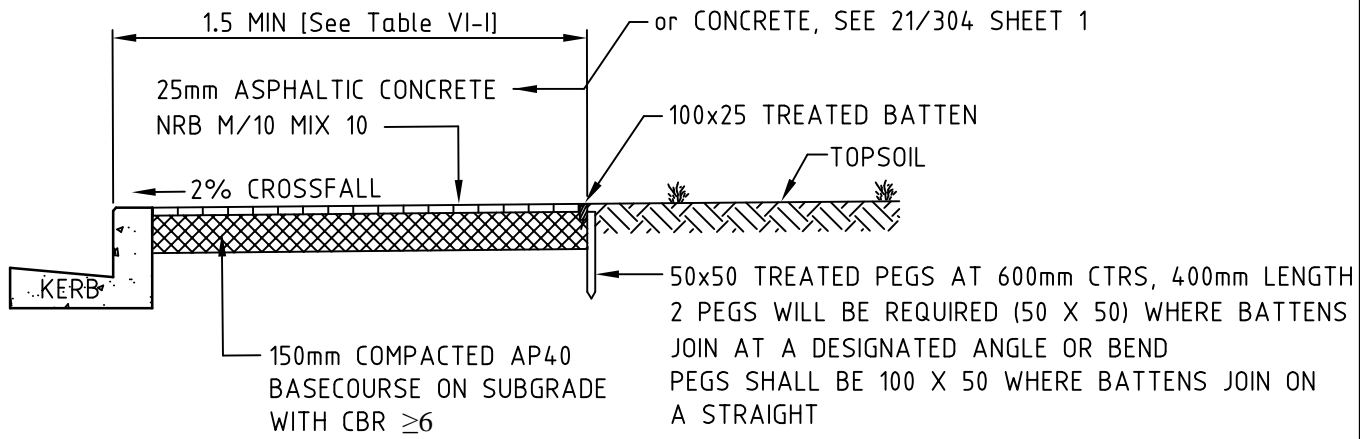

FOOTPATH SECTION

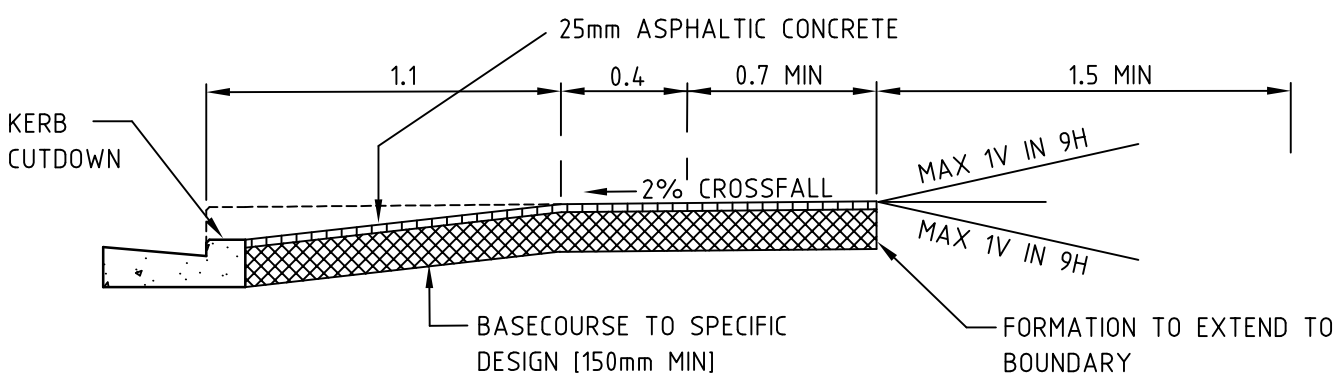

VEHICLE ENTRANCE SECTION

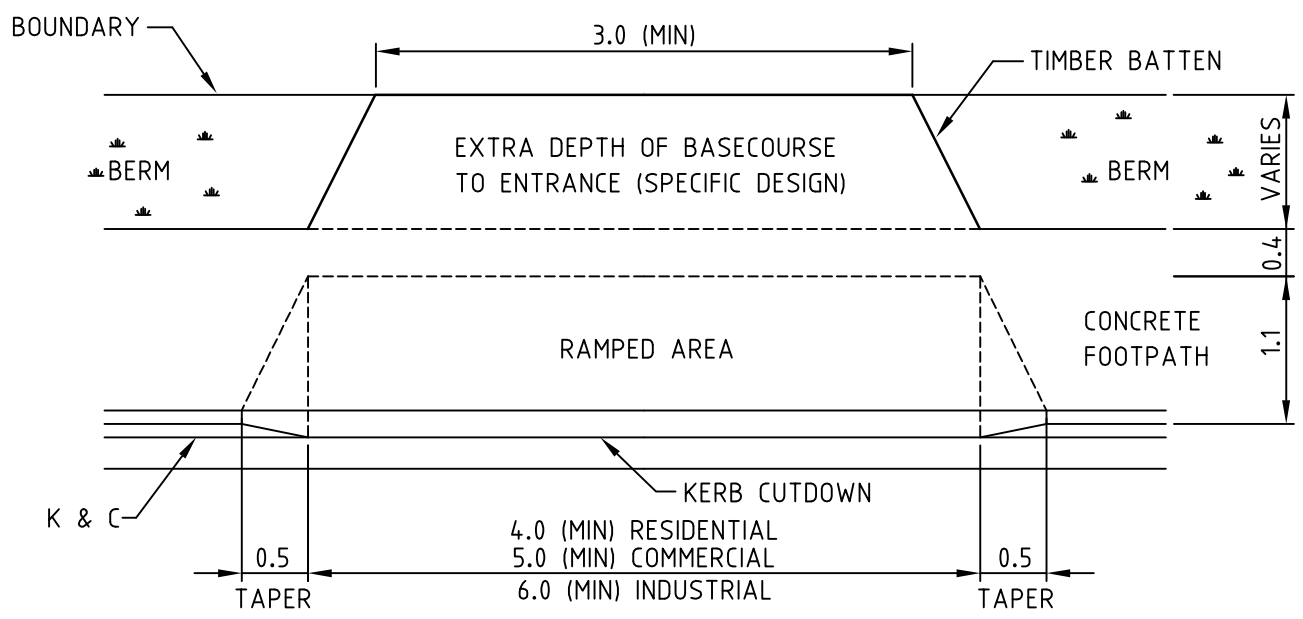

VEHICLE ENTRANCE PLAN

**NELSON
CITY
COUNCIL**

**FOOTPATH
ADJACENT KERB**

ASSET MANAGEMENT DIVISION

APPROVED

MANAGER INFRASTRUCTURAL ASSETS

Feb. 2006

DATE

PLAN No.

21/304

SHEET 2

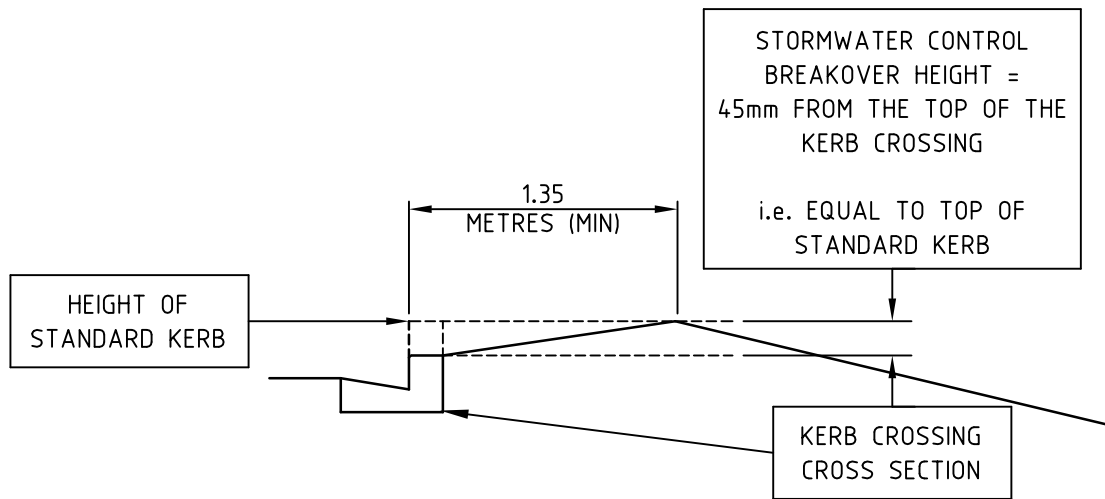

DIMENSIONS OF STORMWATER BREAKOVER CONTROL FOR ACCESSSES BELOW THE ROAD

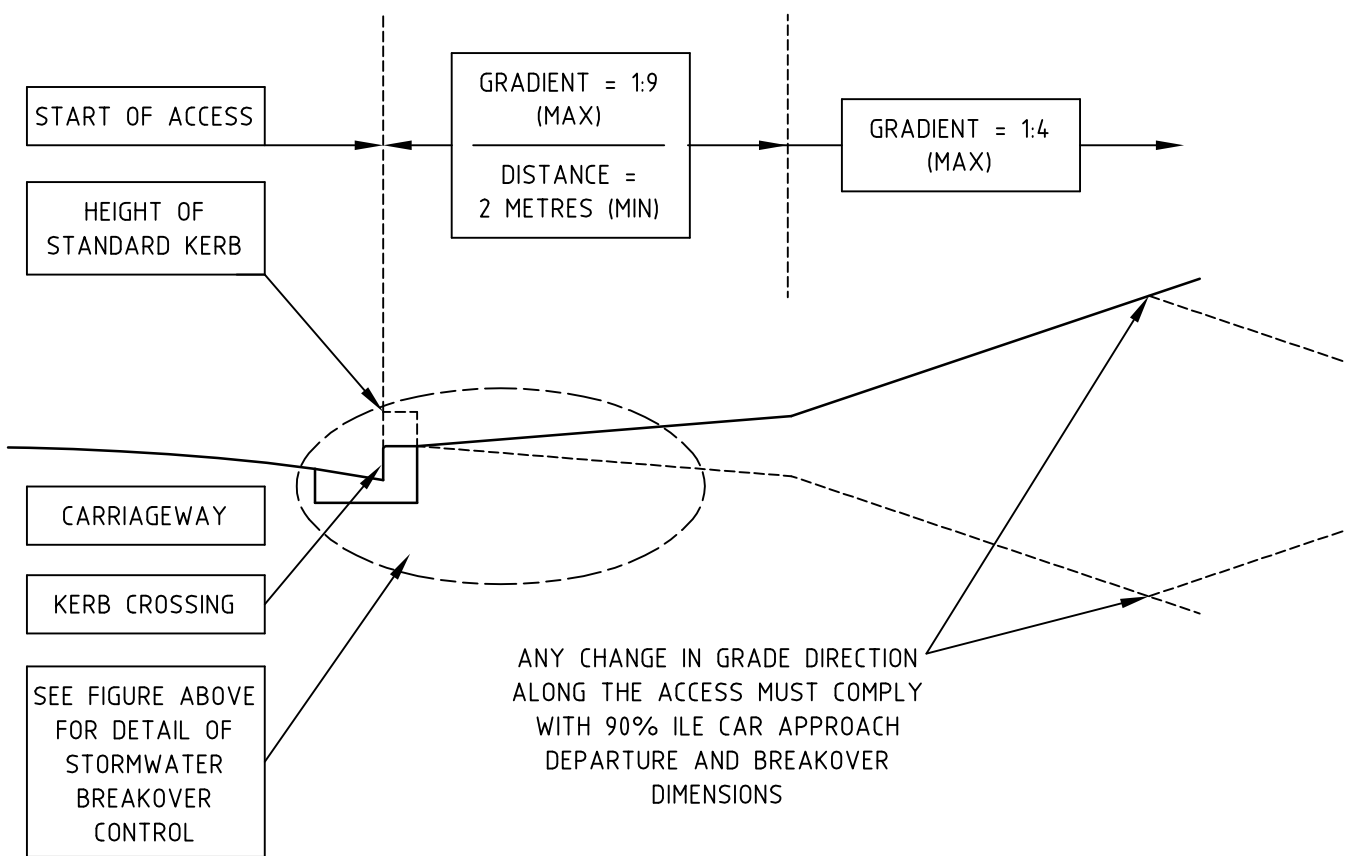

GRADIENT OF ACCESS AND BREAKOVER ANGLES FOR ACCESS TO SITES WHERE THERE IS NO EXISTING OR PROPOSED FOOTPATH

**NELSON
CITY
COUNCIL**

**ACCESS BREAKOVER ANGLES WHERE
NO PROPOSED FOOTPATH**

ASSET MANAGEMENT DIVISION

APPROVED

MANAGER INFRASTRUCTURAL ASSETS

Jan. 2003

DATE

PLAN No.

21/304

SHEET 3

WIDTH VARIES ACCORDING TO ROAD TYPE
(SEE TABLE VI-1)

WEARING SURFACE
(ASPHALTIC CONCRETE OR 2 COAT CHIPSEAL)

KERB & CHANNEL

SUBBASE
(WHERE REQUIRED BY PAVEMENT DESIGN)

AP40 BASECOURSE

- NRB M/4 OR
- TNZ M/5 1990 (NELSON)
- OR AS APPROVED

SUBGRADE
(NATURAL GROUND OR BULK FILL MATERIAL)

FOR CROSS FALL TO CARRIAGEWAY
SEE CAMBER TABLE (21/307)

DEPTHS OF BASECOURSE AND SUBBASE
(WHERE REQUIRED) TO BE AS DETAILED IN
SPECIFIC PAVEMENT DESIGN FOR EACH
INDIVIDUAL STREET

**NELSON
CITY
COUNCIL**

**TYPICAL CROSS SECTION
CARRIAGEWAY**

ASSET MANAGEMENT DIVISION

APPROVED



MANAGER INFRASTRUCTURAL ASSETS

Jan. 2003

DATE

PLAN No.

21/305

SHEET 1

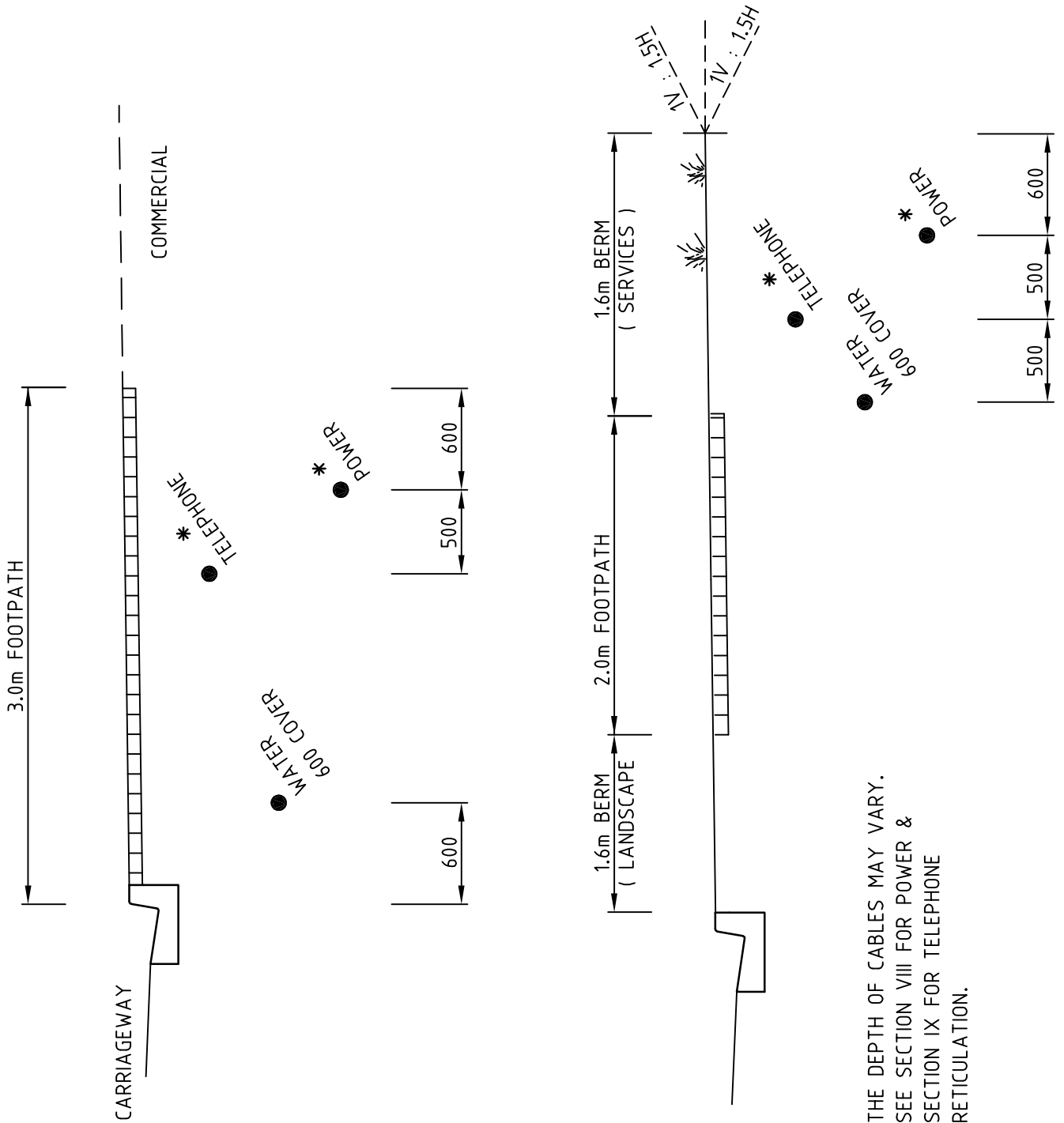

* THE DEPTH OF CABLES MAY VARY.
 SEE SECTION VIII FOR POWER &
 SECTION IX FOR TELEPHONE
 RETICULATION.

**NELSON
 CITY
 COUNCIL**

**TYPICAL CROSS SECTIONS (BERMS)
 TYPE I & II ROADS**

ASSET MANAGEMENT DIVISION

APPROVED *[Signature]* Jan. 2003

 MANAGER INFRASTRUCTURAL ASSETS DATE

PLAN No.
21/305
 SHEET 2

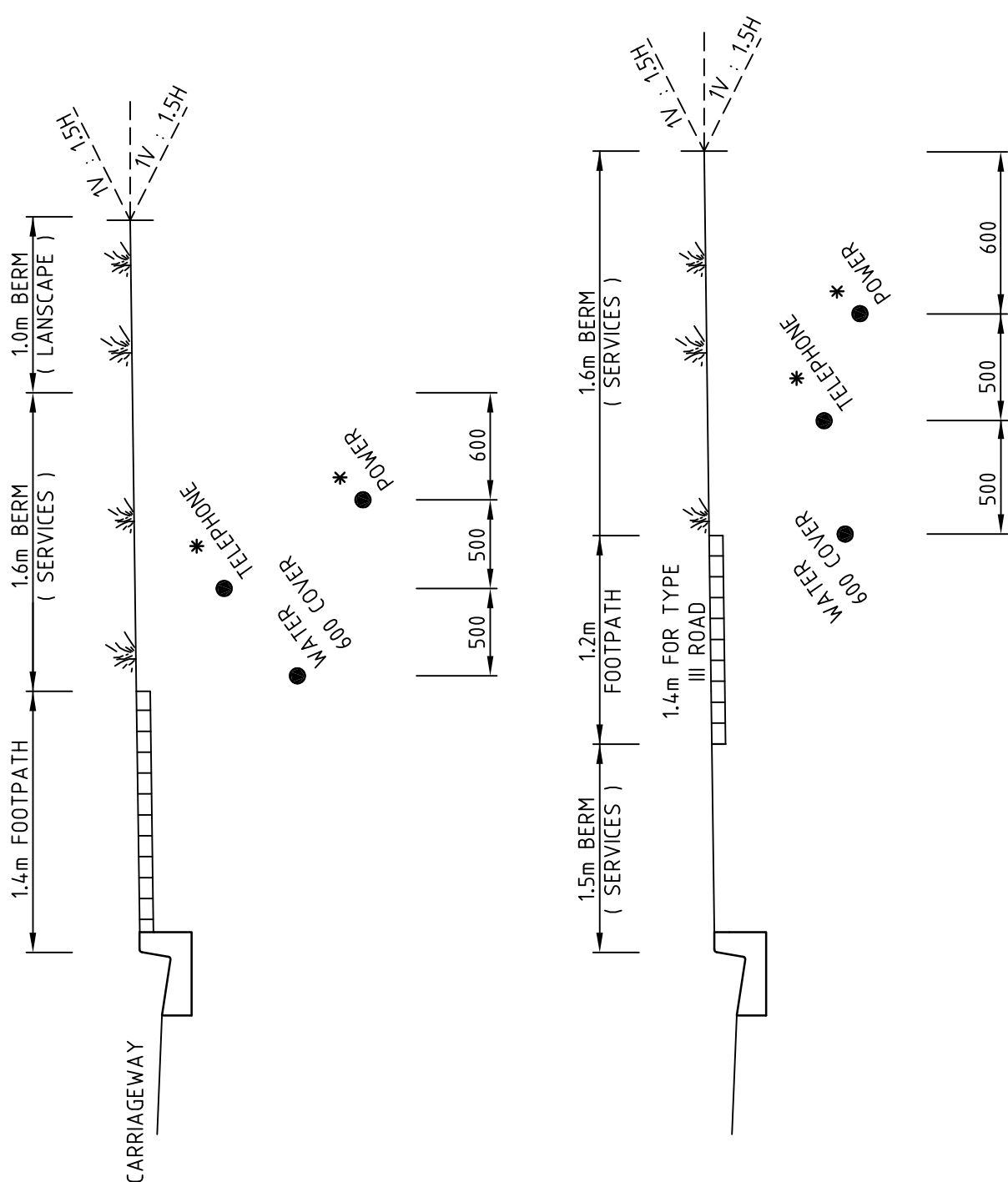

* THE DEPTH OF CABLES MAY VARY.
 SEE SECTION VIII FOR POWER &
 SECTION IX FOR TELEPHONE
 RETICULATION.

**NELSON
 CITY
 COUNCIL**

**TYPICAL CROSS SECTIONS (BERMS)
 TYPE III VI & VII ROADS**

ASSET MANAGEMENT DIVISION
 APPROVED *[Signature]* Jan. 2003
 MANAGER INFRASTRUCTURAL ASSETS DATE

PLAN No.
21/305
 SHEET 3

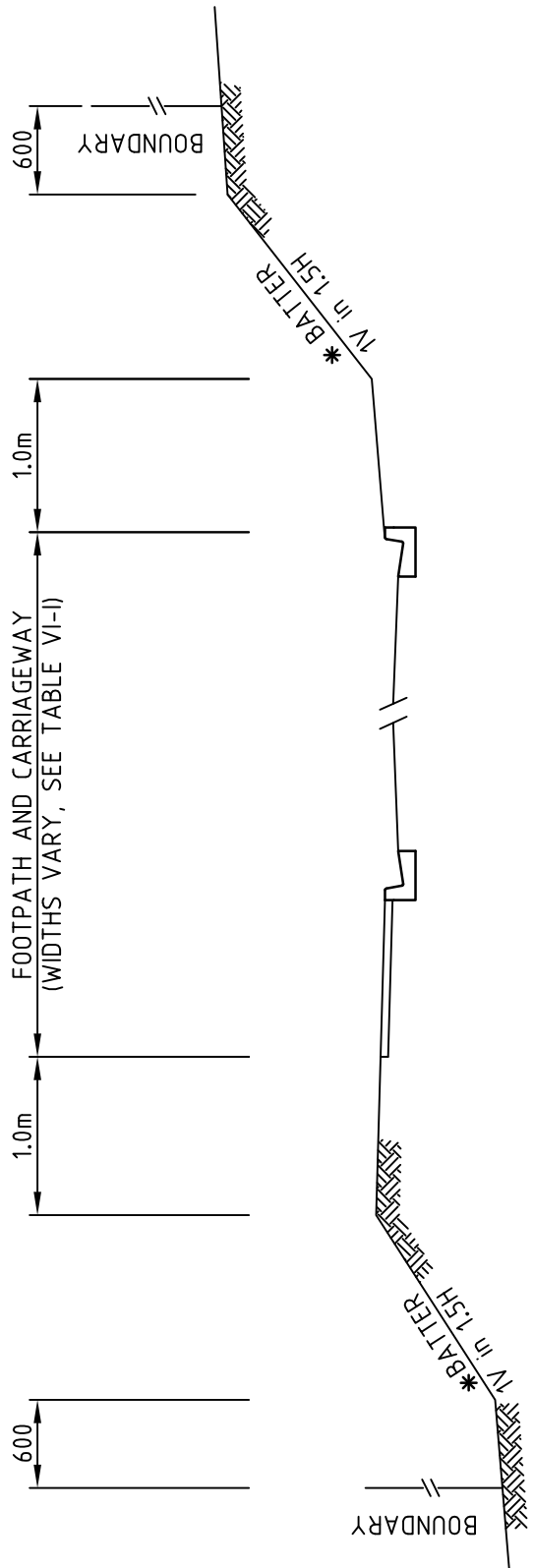

*** NOTES:**

- BATTER SLOPES MAY BE REPLACED BY RETAINING WALLS TO SPECIFIC DESIGN WHERE APPROVED BY THE COUNCIL
- THE 1.0m DISTANCE FROM BACK OF FOOTPATH/KERB MAY BE INCREASED WHERE THE AREA IS REQUIRED AS SERVICE STRIPS BY TABLE VI-1

**NELSON
CITY
COUNCIL**

**TYPICAL CROSS SECTIONS ROADSIDE
BATTERS**

ASSET MANAGEMENT DIVISION

APPROVED 

MANAGER INFRASTRUCTURAL ASSETS

Jan. 2003

DATE

PLAN No.

21/305

SHEET 4

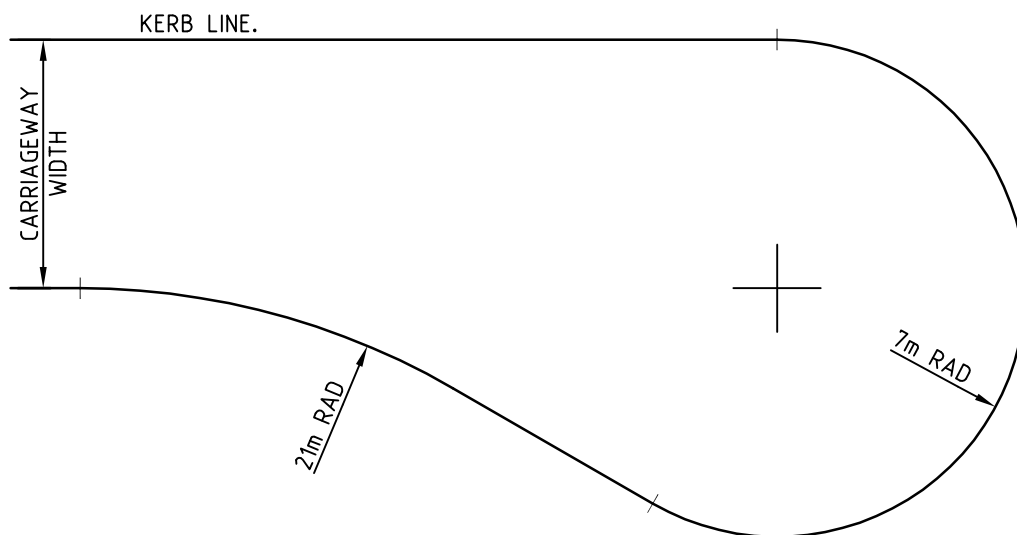

NOTE:

1. NO KERBSIDE PARKING WITHIN THE TURNING CIRCLE
2. ALL ROAD MARKING TO BE 100mm WIDE WHITE PAINTED LINES.
3. FOR STEEP HILLSIDE DEVELOPEMENT THE TURNING AREA CAN BE A 'FISH-TAIL' OR 'HAMMERHEAD' DESIGN PROVIDED THE TURNING AREA PERMITS A 90 PERCENTILE 2 AXLE TRUCK TO UNDERTAKE A 3 POINT TURN

**NELSON
CITY
COUNCIL**

CUL-DE-SAC TURNING CIRCLES

ASSET MANAGEMENT DIVISION

APPROVED

MANAGER INFRASTRUCTURAL ASSETS

Jan. 2003

DATE

PLAN No.

21/306

SHEET 1

CROSSFALL FOR ROADWAY 3%-4% (1 IN 33 - 1 IN 25)

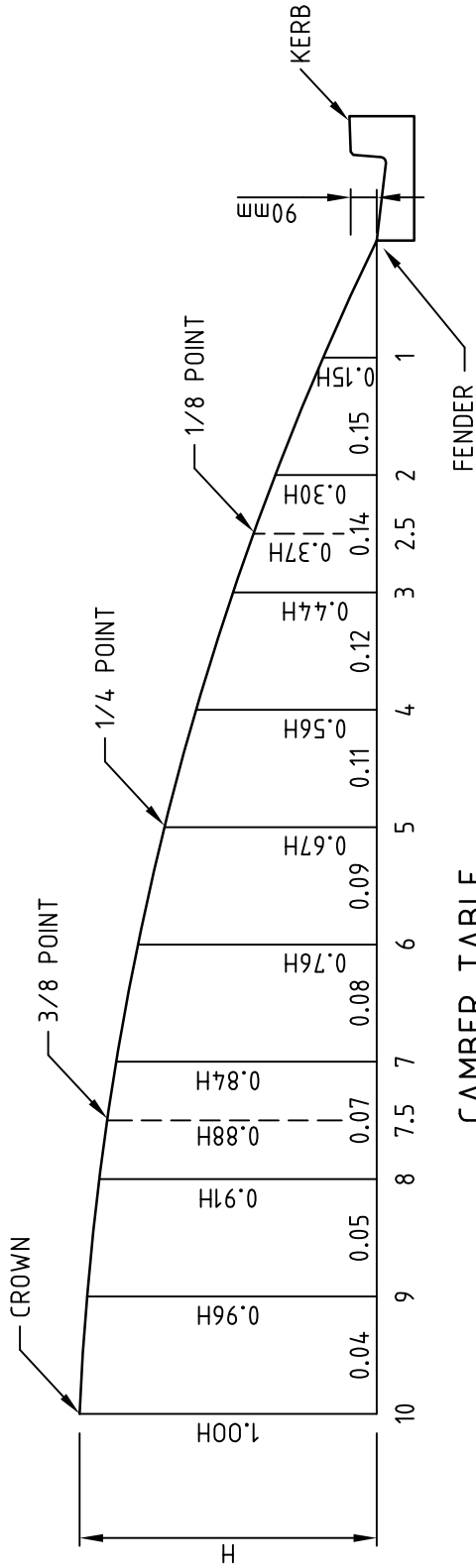

CAMBER TABLE

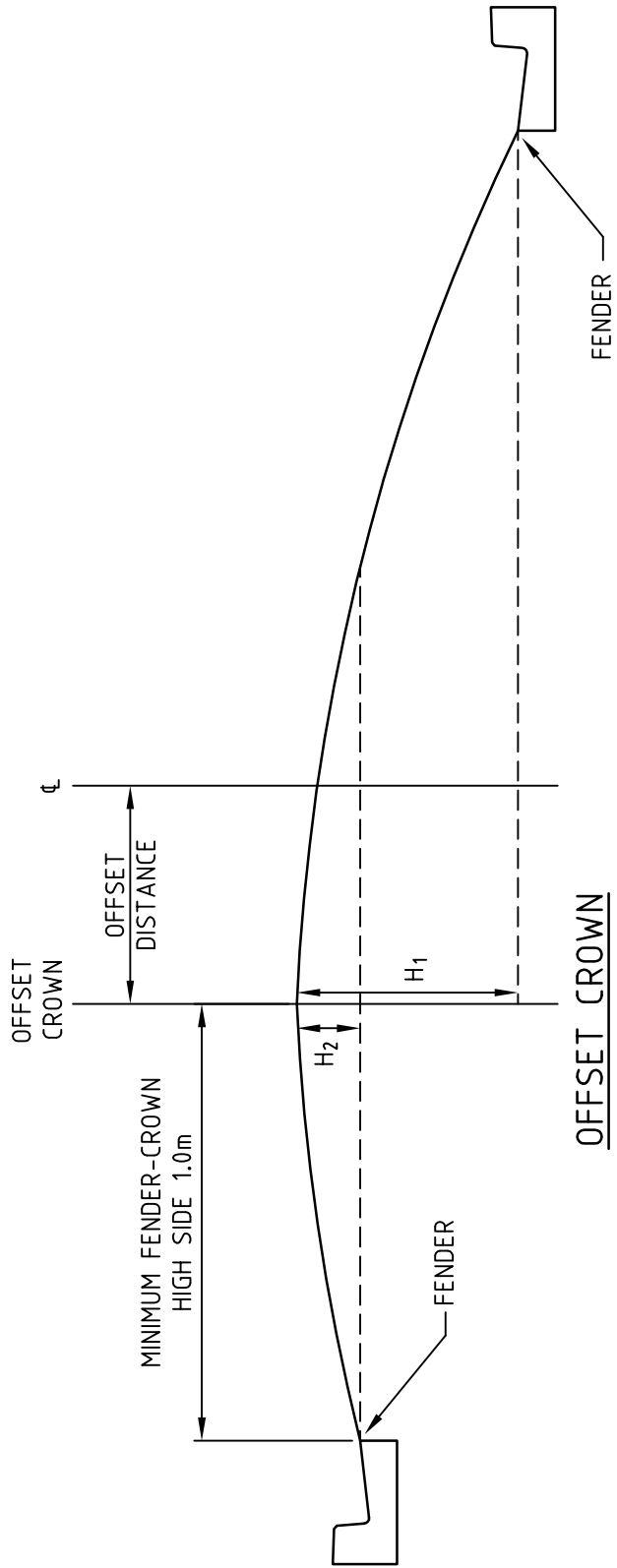

NOTE:
CARRIAGEWAY CAMBER ON EITHER SIDE OF OFFSET CROWN SHOULD BE BALANCED
IN TERMS OF THE ABOVE CAMBER TABLES.

**NELSON
CITY
COUNCIL**

CAMBER TABLE

ASSET MANAGEMENT DIVISION

APPROVED

MANAGER INFRASTRUCTURAL ASSETS

Jan. 2003

DATE

PLAN No.

21/307

SHEET 1

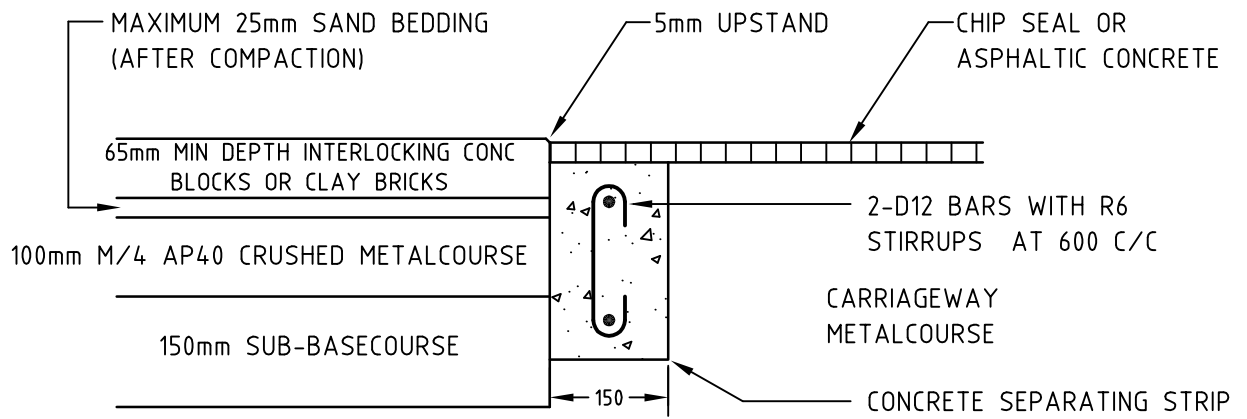

CARRIAGEWAY THRESHOLDS (LONGITUDINAL SECTION)

65mm MINIMUM INTERLOCKING CONCRETE
BLOCKS OR CLAY BRICKS IN 45°
HERRINGBONE PATTERN

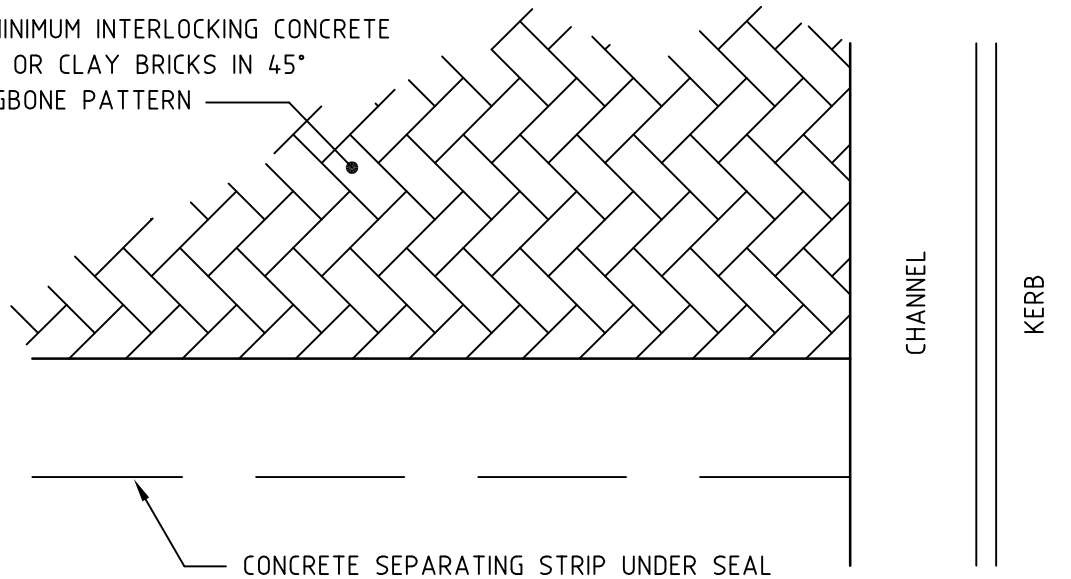

CARRIAGEWAY THRESHOLDS PART PLAN

NOTES:

1. CONCRETE BLOCKS SHALL COMPLY WITH NZS 3116: 1981
2. CLAY BRICKS SHALL COMPLY WITH THE AUSTRALIAN BRICK DEVELOPMENT RESEARCH INSTITUTES "SPECIFICATION FOR FIRED CLAY PAVERS FOR SITES SUBJECTED TO VEHICULAR AND PEDESTRIAN TRAFFIC"
3. LAYING OF PAVERS SHALL COMPLY WITH THE CEMENT AND CONCRETE ASSOCIATION OF NZ "INTERLOCKING CONCRETE BLOCK ROAD PAVEMENTS" (SEPT 1988)

**NELSON
CITY
COUNCIL**

CARRIAGEWAY THRESHOLDS (CONCRETE BLOCKS OR CLAY BRICKS)

ASSET MANAGEMENT DIVISION

APPROVED

MANAGER INFRASTRUCTURAL ASSETS

Jan. 2003

DATE

PLAN No.

21/308

SHEET 1

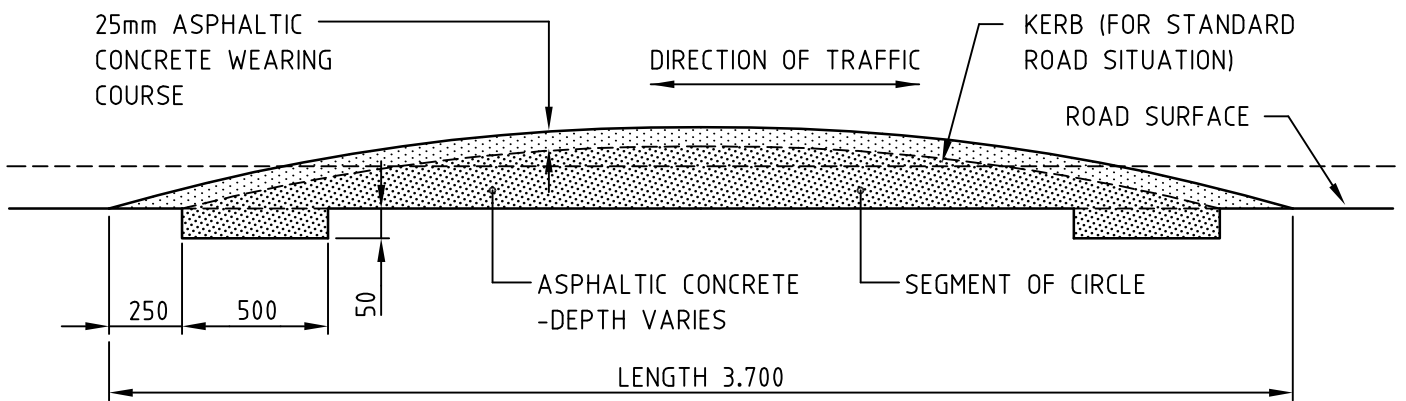
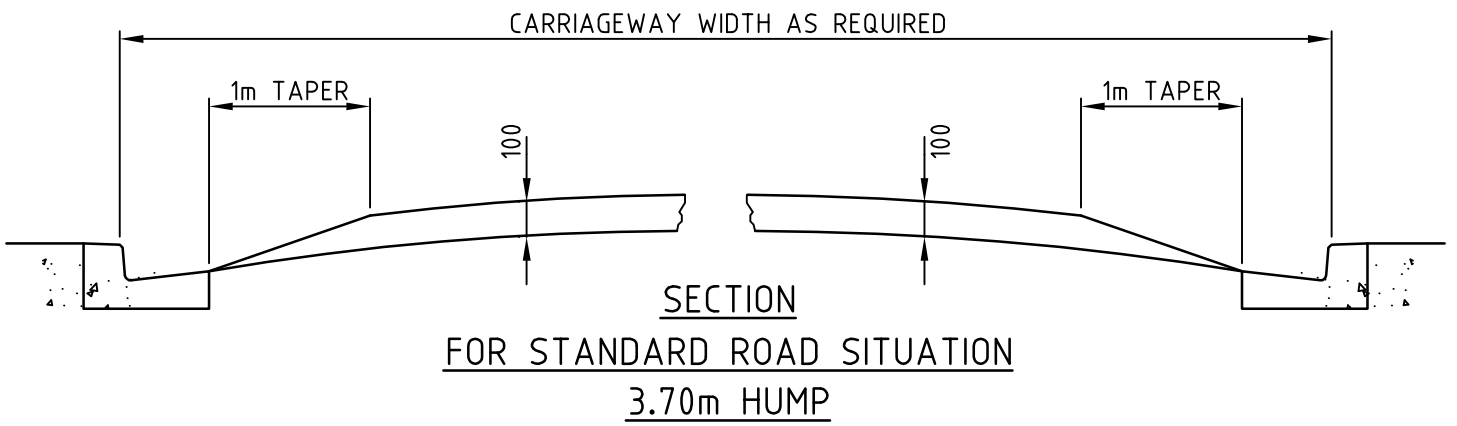

SECTION-ROAD HUMP PROFILE
FOR KERB AND CHANNEL
STANDARD ROAD SITUATION

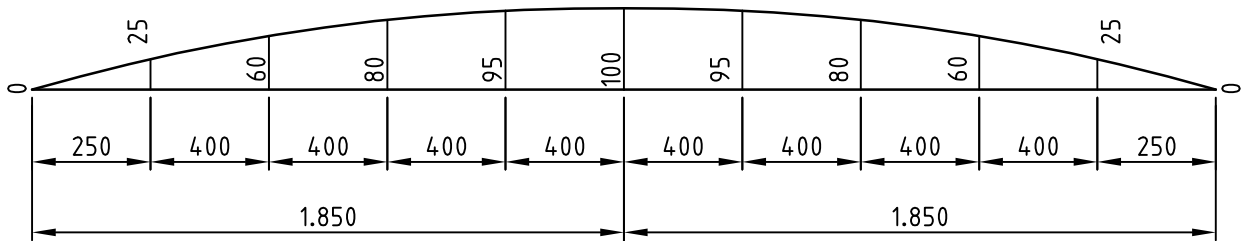

SETTING OUT PROFILE
FOR SECTION (ALL CASES)

**NELSON
 CITY
 COUNCIL**

ROAD HUMP DETAILS

ASSET MANAGEMENT DIVISION

APPROVED

MANAGER INFRASTRUCTURAL ASSETS

Jan. 2003

DATE

PLAN No.

21/309

SHEET 1

PLAN 21-310 has been
REMOVED from the
2003 STANDARDS
This sheet is maintained
to ensure Numbering continuity.

**NELSON
CITY
COUNCIL**

PLAN REMOVED FROM
2003 STANDARDS

ASSET MANAGEMENT DIVISION

APPROVED



.....
MANAGER INFRASTRUCTURAL ASSETS

Jan. 2003

.....
DATE

PLAN No.

21/310

SHEET 1

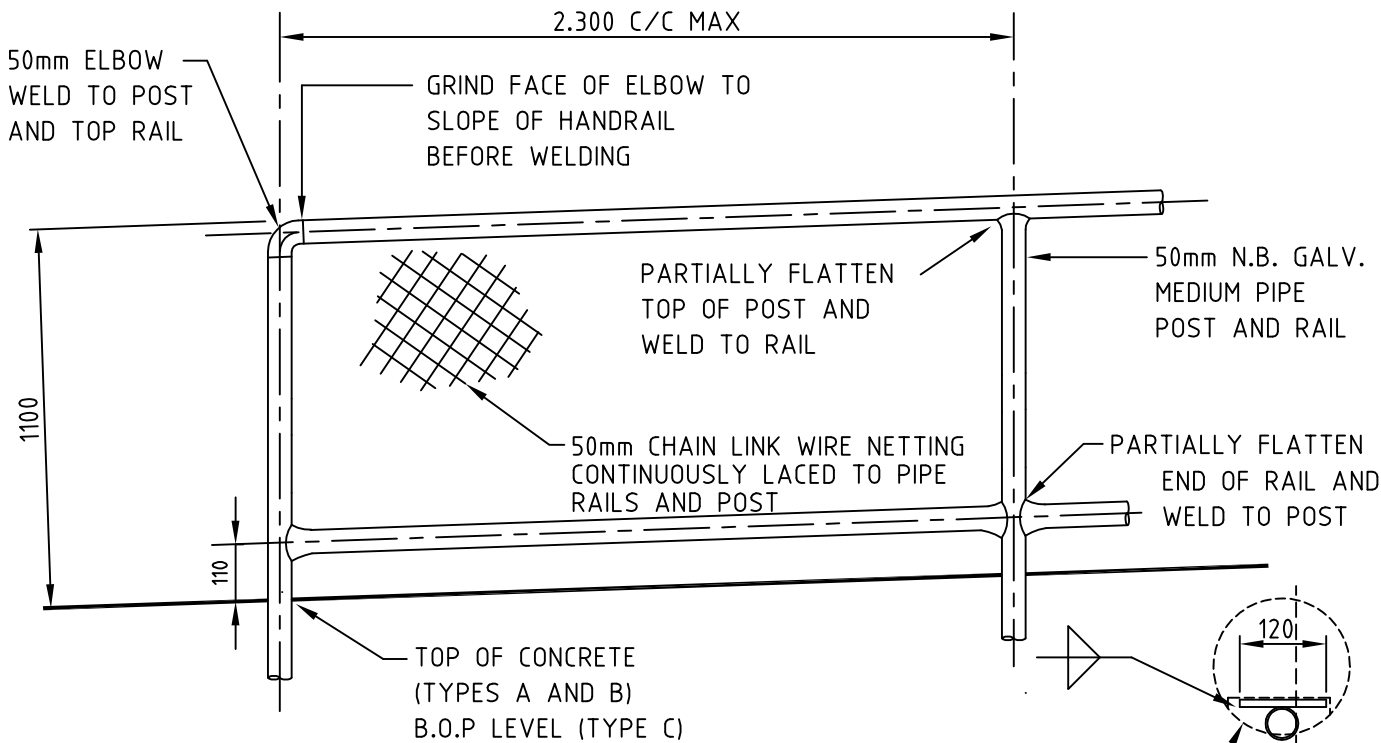

TYPICAL ELEVATION

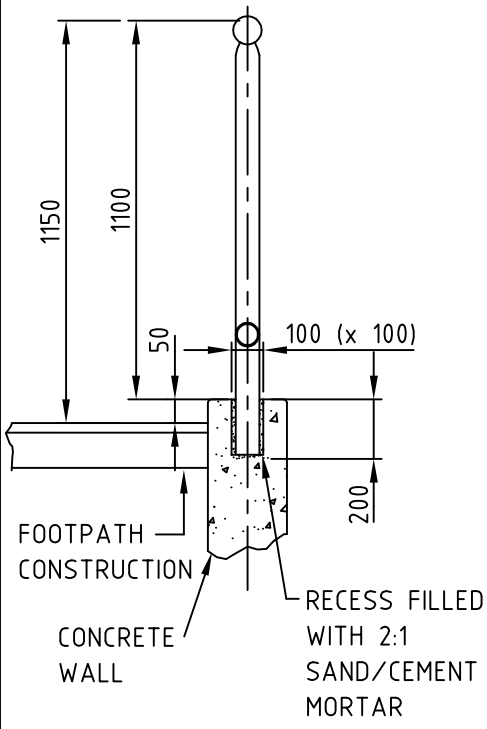

**TYPE A
RECESSED**

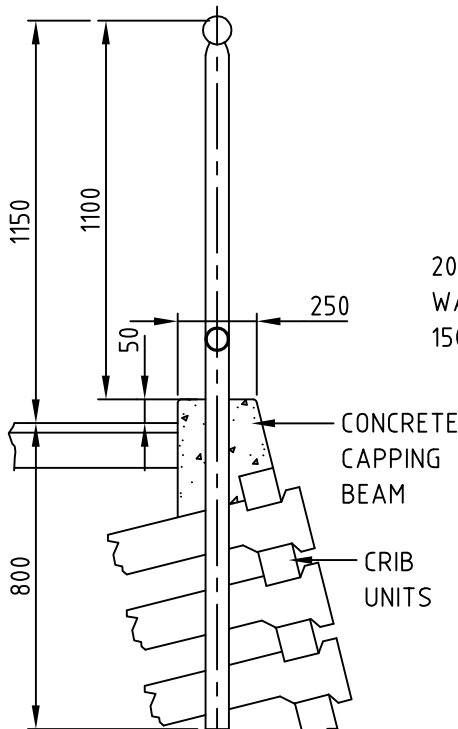

**TYPE B
CRIB WALL**

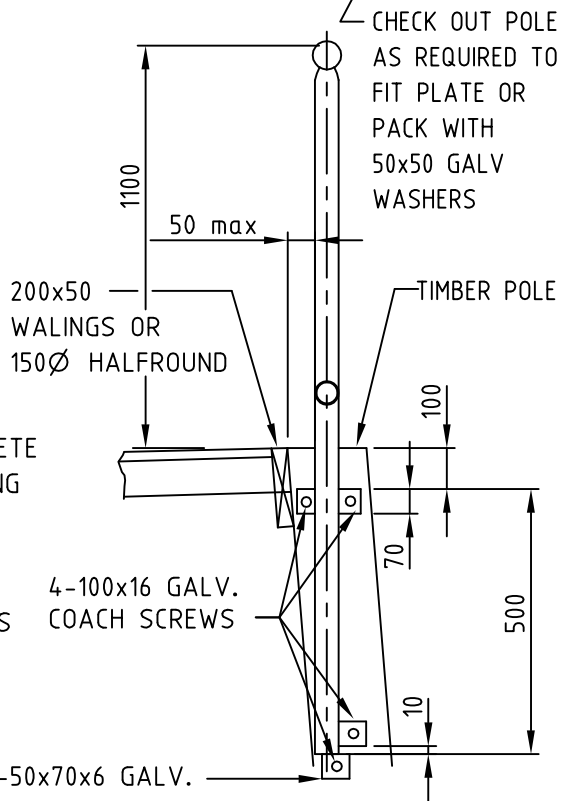

**TYPE C
TIMBER WALL**

**NELSON
CITY
COUNCIL**

HANDRAILS

ASSET MANAGEMENT DIVISION

APPROVED

MANAGER INFRASTRUCTURAL ASSETS

Jan. 2003

DATE

PLAN No.

21/311

SHEET 1

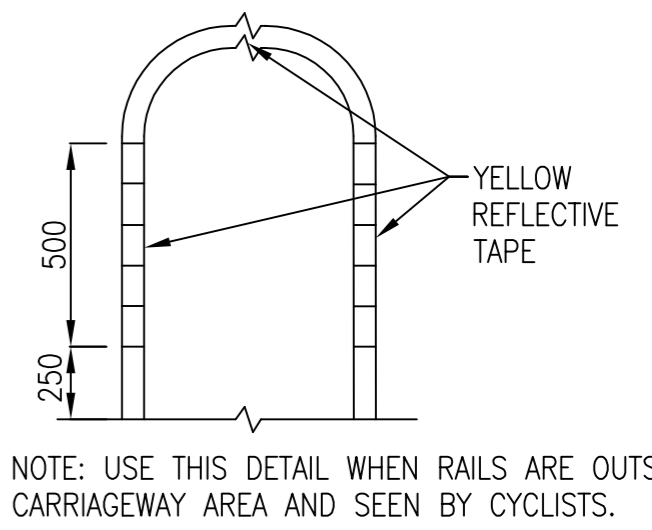
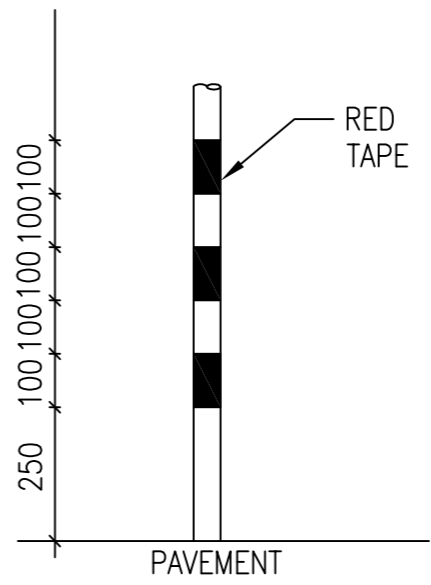
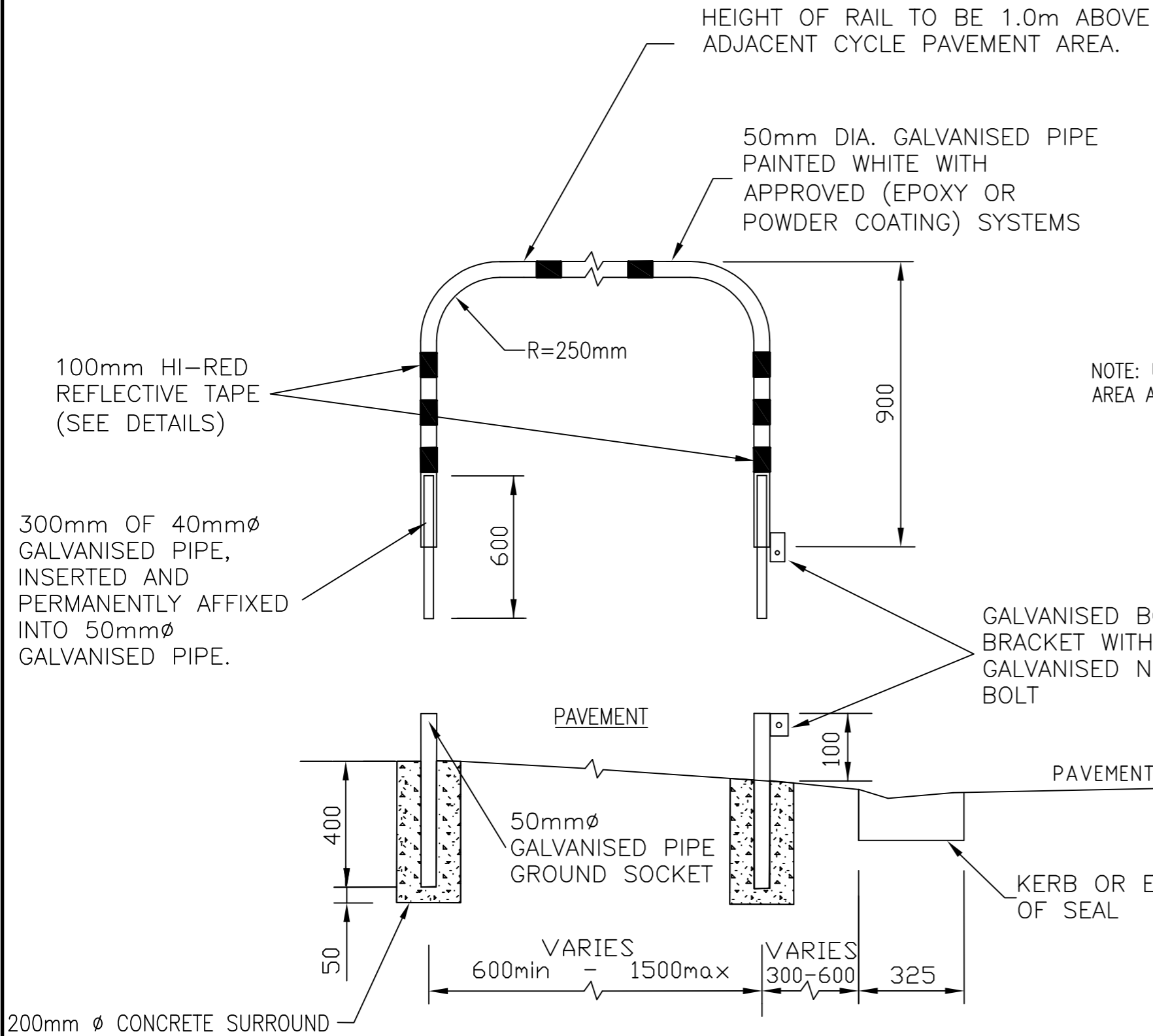

NOTE: USE THIS DETAIL WHEN RAILS ARE WITHIN CARRIAGEWAY AREA AND SEEN BY MOTOR VEHICLES.

DETAILS

- NOTE:
- 1 RAIL TO BE PLACED AT EDGE OF CYCLEWAY PAVEMENT OR 300mm FROM EDGE OF PEDESTRIAN REFUGES.
 - 2 TOP RAIL SHALL BE 1.0m ABOVE ADJACENT PAVEMENT

HOLD RAILS TO BE FREE FROM FOOTPATH TO PREVENT OBSTRUCTING PEDESTRIANS

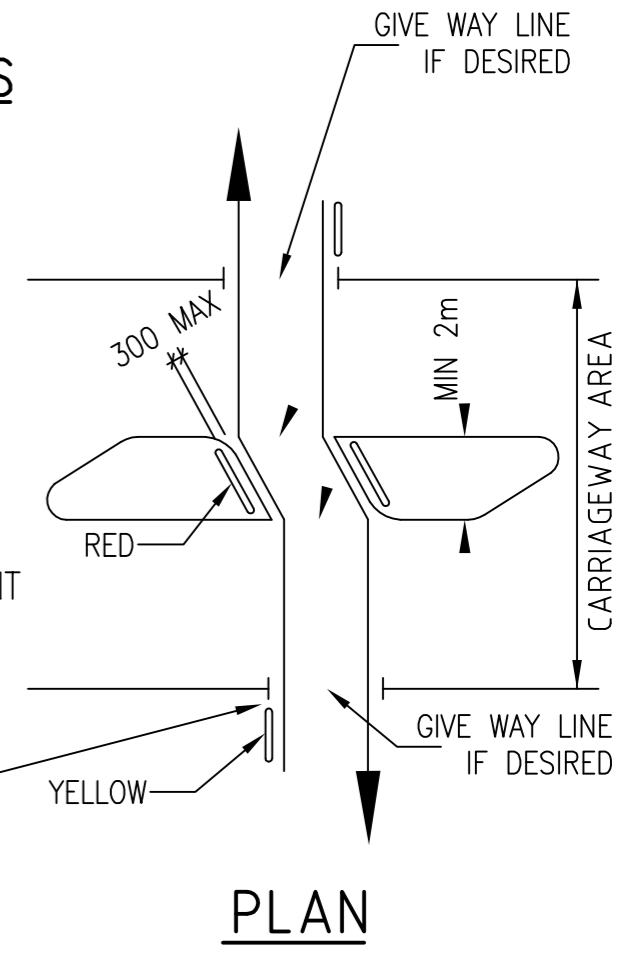

HOLDING RAIL ELEVATION

| | | |
|----------------------------|--|--------------------------------------|
| NELSON CITY COUNCIL | CYCLE HOLDING RAIL | |
| | ASSET MANAGEMENT DIVISION APPROVED  06/04/2005 MANAGER INFRASTRUCTURAL ASSETS DATE | PLAN No. 21/311 SHEET 2 |

PLASTER CAP PERMANENTLY AFFIXED WITH DOWEL STARTER AND PAINTED WHITE.

300mm OF 140mmØ GALVANISED PIPE, 4mm THICK, INSERTED AND PERMANENTLY AFFIXED INTO 150mmØ GALVANISED PIPE.

PADLOCK BRACKET (SEE DETAIL BELOW)

150mm GALVANISED PIPE 4mm THICK

FINISHED SURFACE

D12 STIRRUP

4 - D12 BARS
MIN 50mm FROM PIPE
MIN COVER 50mm

600mm x 500mm DEEP 28 MPa CONCRETE FOUNDATION.

ELEVATION

NOTES:

- * ALL STEELWORK SHALL BE PRIMED AND PAINTED WHITE
- * PADLOCK TO BE POSITIONED FACING DIRECTION OF CYCLE TRAFFIC

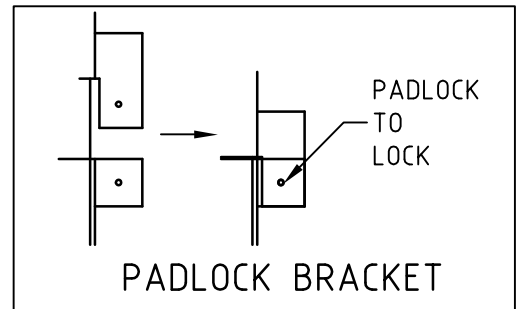

NELSON CITY COUNCIL

REMOVABLE CYCLE BOLLARD

ASSET MANAGEMENT DIVISION

PLAN No.

APPROVED

Jan. 2003

21/312

MANAGER INFRASTRUCTURAL ASSETS

DATE

SHEET 1

PLASTER CAP PERMANENTLY
AFFIXED WITH DOWEL STARTER
AND PAINTED WHITE.

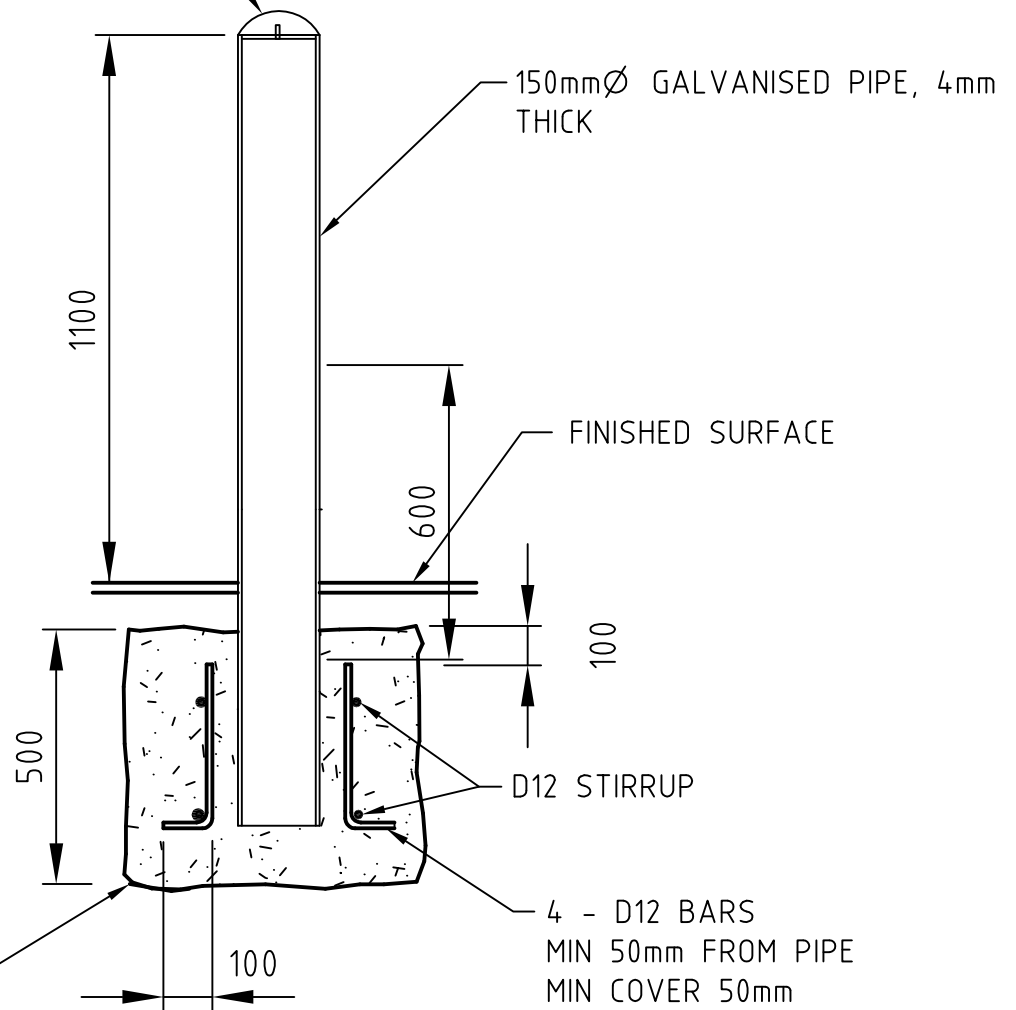

600mm x 500mm
DEEP 28 MPa
CONCRETE FOUNDATION.

ELEVATION

NOTES:

* ALL STEELWORK SHALL BE PRIMED AND PAINTED WHITE WITH REFLECTORISED STRIPS VISABLE FROM BOTH WAYS

**NELSON
CITY
COUNCIL**

STANDARD CYCLE BOLLARD

ASSET MANAGEMENT DIVISION
APPROVED *[Signature]* Jan. 2003
MANAGER INFRASTRUCTURAL ASSETS DATE

PLAN No.
21/312
SHEET 2

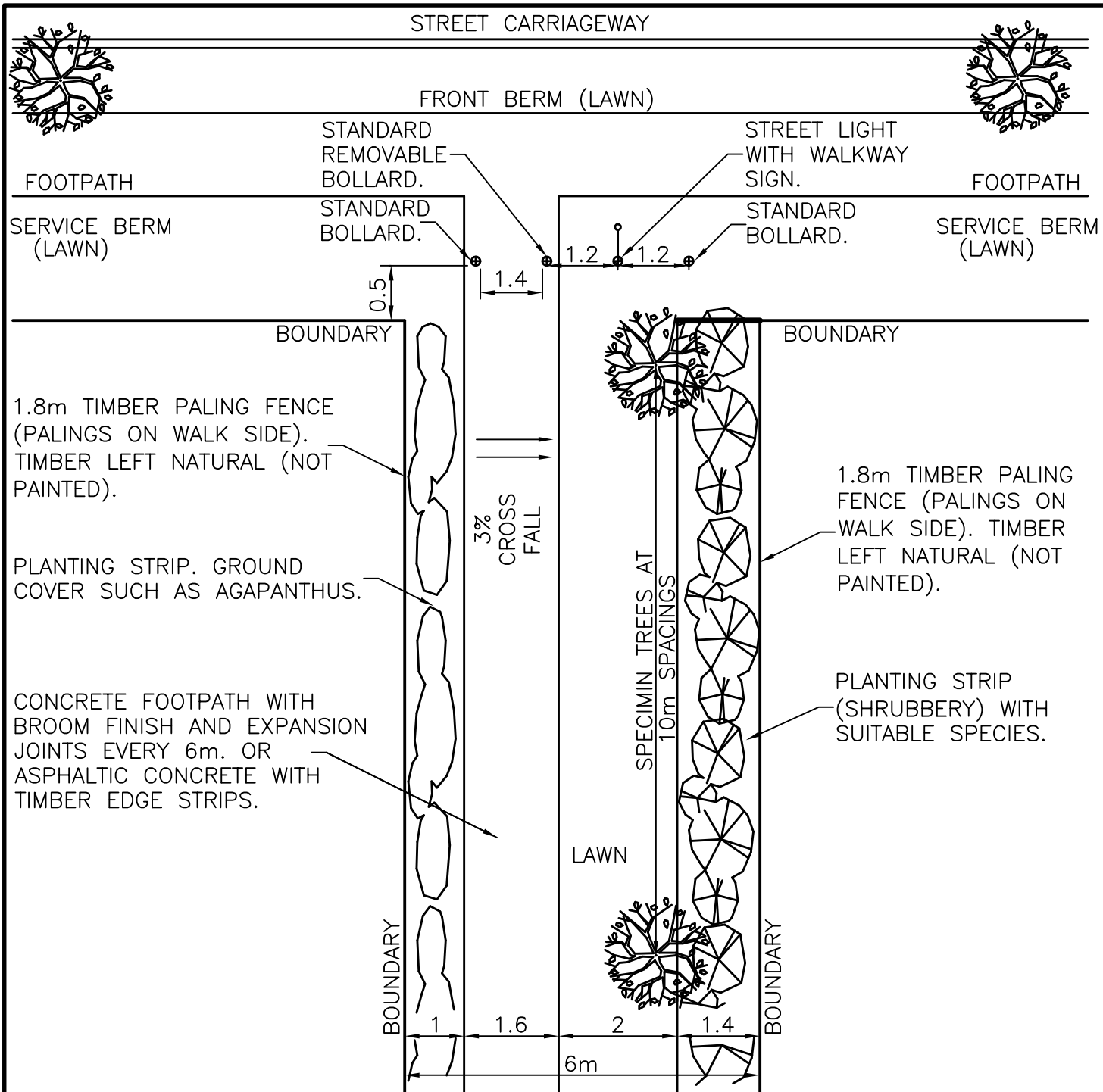

NOTE:

WITH WALKWAYS ORIENTED EAST/WEST PLANT TREES ON THE NORTHERN SIDE OF THE FOOTPATH.

IF STEPS ARE REQUIRED FOR GRADES GREATER THAN 1:5 THEN STREET LIGHTING SHALL BE PROVIDED AS WELL AS A HANDRAIL TO ONE SIDE.

STEPS SHALL BE NO NARROWER THAN 300mm TREAD WITH 150-180 RISER. A LANDING SHALL BE PROVIDED EVERY 20 STEPS.

FOR BOLLARD DETAILS SEE 21/312, SHEETS 1 AND 2

**NELSON
CITY
COUNCIL**

STANDARD WALKWAY REQUIREMENTS

ASSET MANAGEMENT DIVISION

APPROVED

12/09/2001

MANAGER BUSINESS & COMMUNITY ASSETS DATE

PLAN No.

21/313

SHEET 1

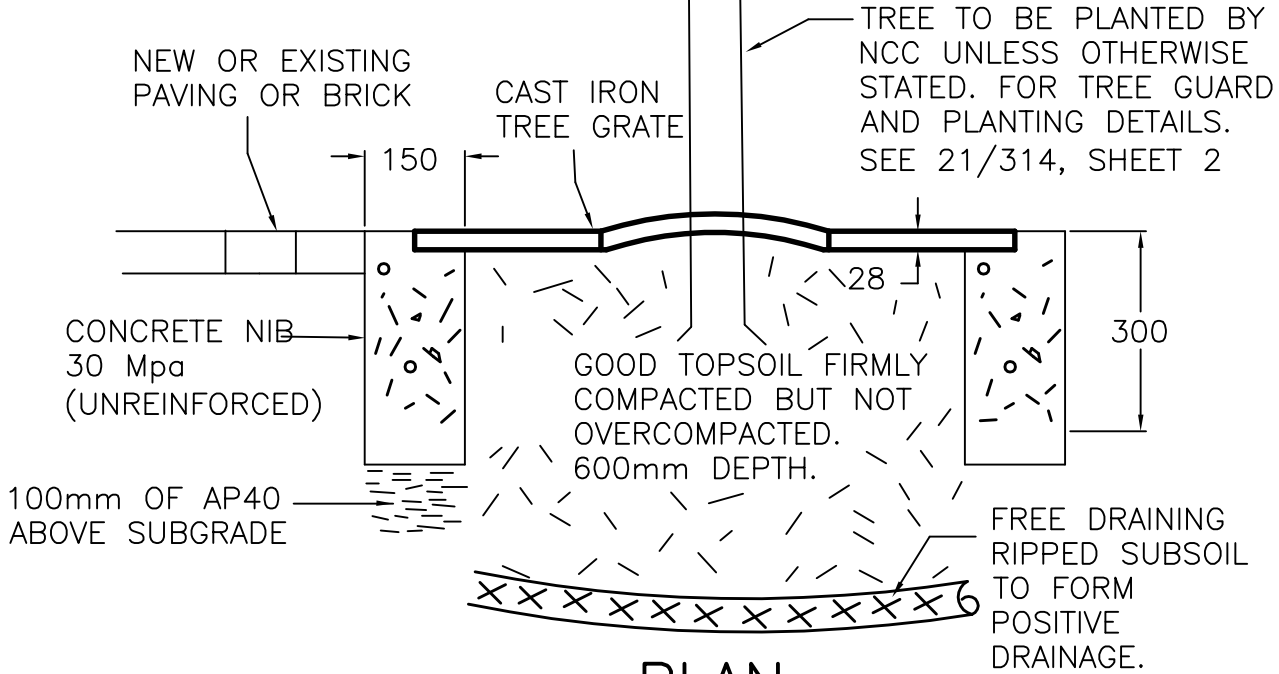

PLAN

NOT TO SCALE

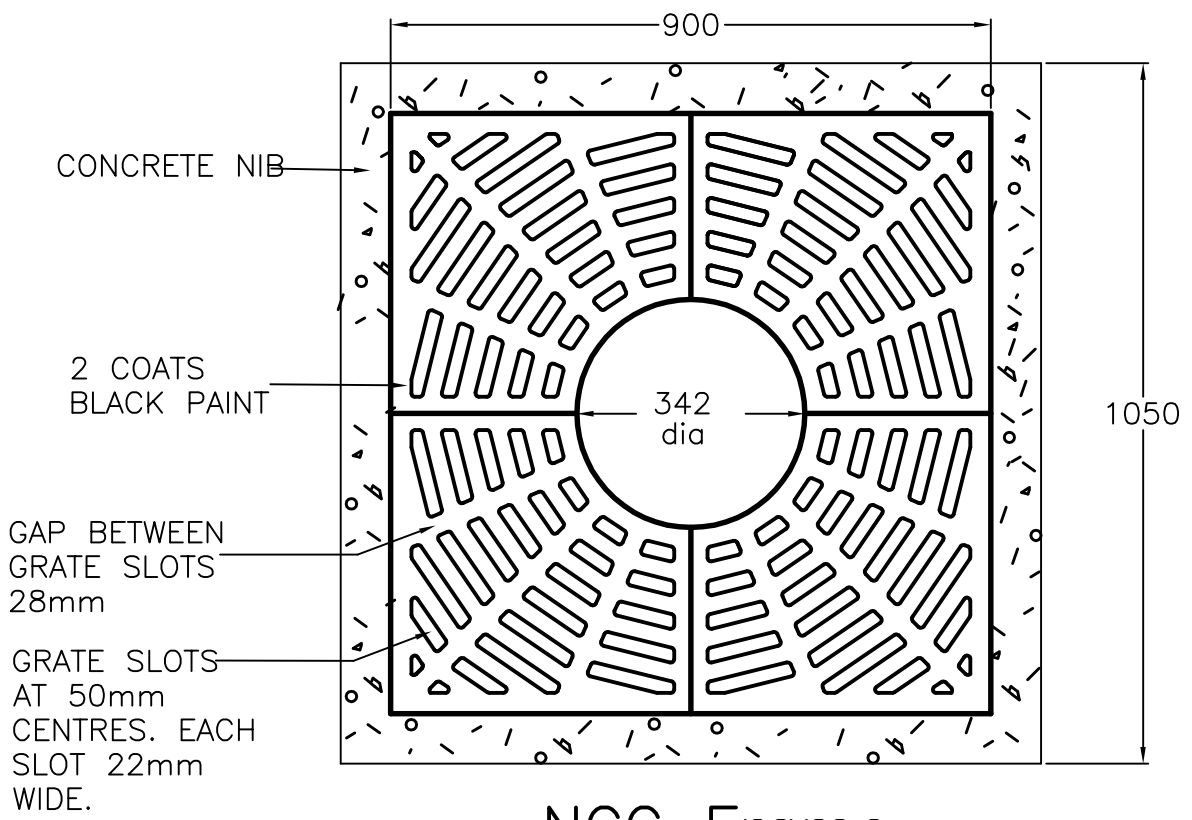

NCC Frame

NOT TO SCALE

**NELSON
CITY
COUNCIL**

TREE GRATE PLANTER DETAILS

ASSET MANAGEMENT DIVISION
 APPROVED *John Reall* 12/09/2001
 MANAGER BUSINESS & COMMUNITY ASSETS DATE

PLAN No.
21/314
 SHEET 1

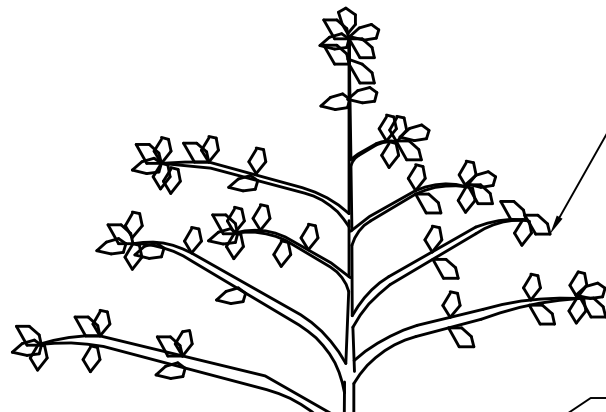

SELECTED 1.8m+ TREE GROWN IN A PB90 AND TRAINED AS A STREET TREE. PRUNE TO SHAPE AFTER PLANTING. REMOVE DAMAGED BRANCHES AS REQUIRED.

FOR EXTRA INITIAL SUPPORT THE TREE SHOULD BE TIED IN TWO OPPOSITE DIRECTIONS WITH A SUITABLE LENGTH OF BIKE TUBE.

STANDARD NCC TREE GUARD PAINTED IN GLOSS BLACK ENAMEL (POWDER COAT).

IF IRRIGATION IS NOT AVAILABLE, A 50mm GAP SHOULD BE LEFT BETWEEN THE GRATE AND THE SOIL TO ALLOW A 'WELL' FOR TREE WATERING. THE GRATES WILL BE SUPPORTED BY THE CONCRETE PLANTER.

TREE GUARD BOLTED TO TREE GRATE. DRILL AND TAP GRATE IN WORKSHOP. ENSURE TREE GUARD IS PERPENDICULAR.

REINFORCED PRECAST CONCRETE PLANTER. CAREFULLY PLACED TO MATCH THE LEVELS AND GRADES OF KERB AND FOOTPATH.

TREE TO BE PLANTED BY EXPERIENCED STAFF. PRUNE ANY DAMAGED ROOTS, AND APPLY SLOW RELEASE FERTILISER.

50/50 MIX OF COMPOST AND GOOD CLEAN TOPSOIL. EVENLY COMPACTED AROUND ROOTS OR ROOT BALL.

NOTE:

DO NOT APPLY SLOW RELEASE HERBICIDE GRANULES IN THE VICINITY OF STREET TREES.

REMOVE BOTH GRATES AND GUARD AFTER 5 YEARS FROM PLANTING.

TOP UP TO PATH LEVEL WITH PEA METAL OR SIMILAR.

2x4 LITRE/HOUR DRIPPER IRRIGATION IF POSSIBLE.

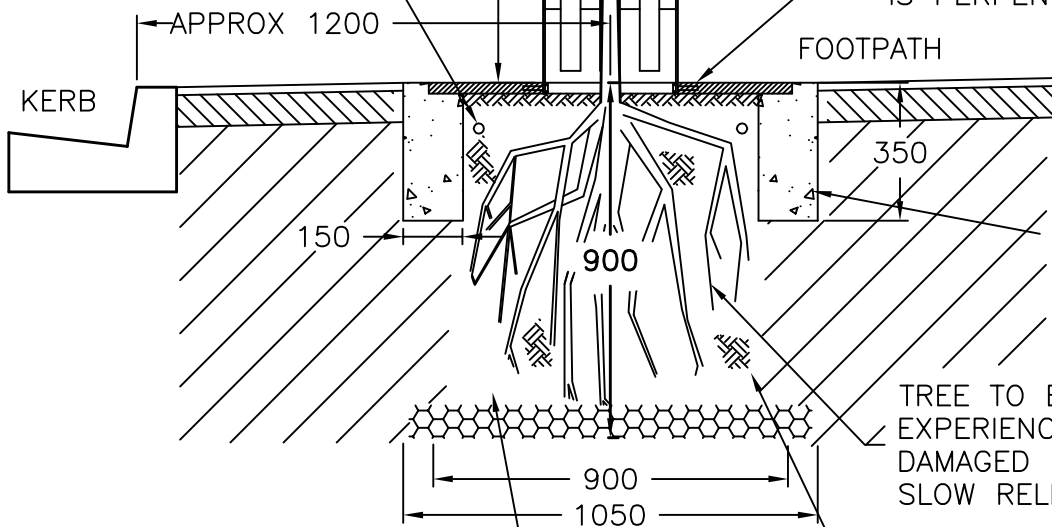

EXCAVATE A ROOT WELL 900mm DEEP AND ENSURE THE BOTTOM IS FREE DRAINING. BACKFILL WITH TOP QUALITY TOPSOIL.

**NELSON
CITY
COUNCIL**

STREET TREE PLANTER DETAIL

ASSET MANAGEMENT DIVISION

APPROVED

12/09/2001

MANAGER BUSINESS & COMMUNITY ASSETS DATE

PLAN No.

21/314

SHEET 2

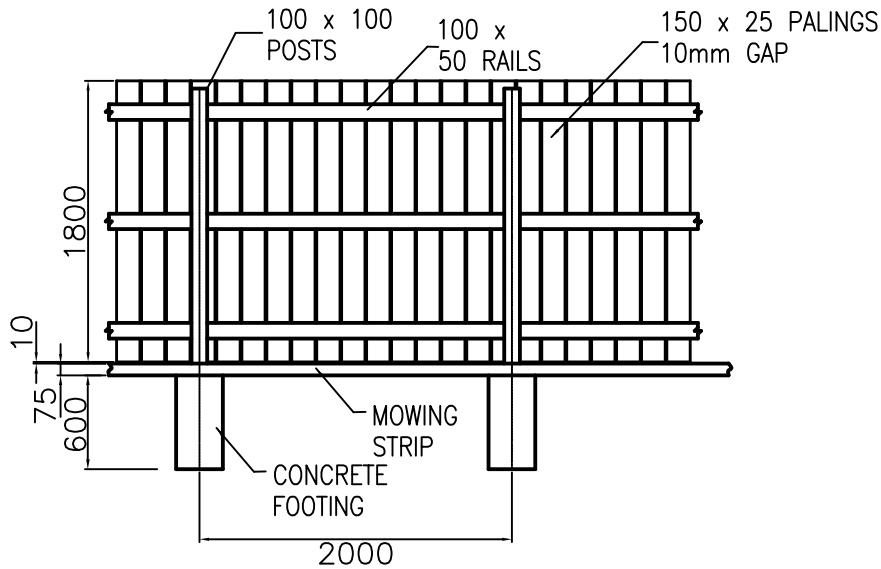

ELEVATION
NTS

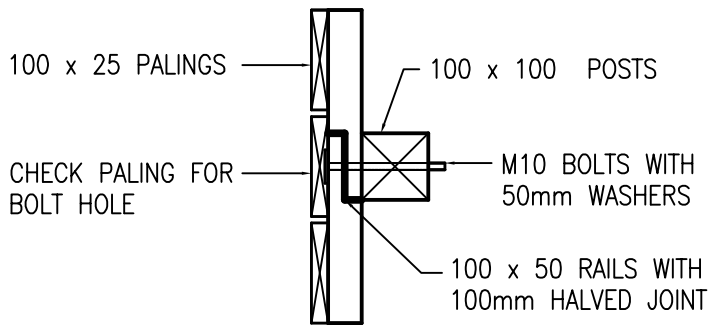

RAIL FIXING DETAIL
NTS

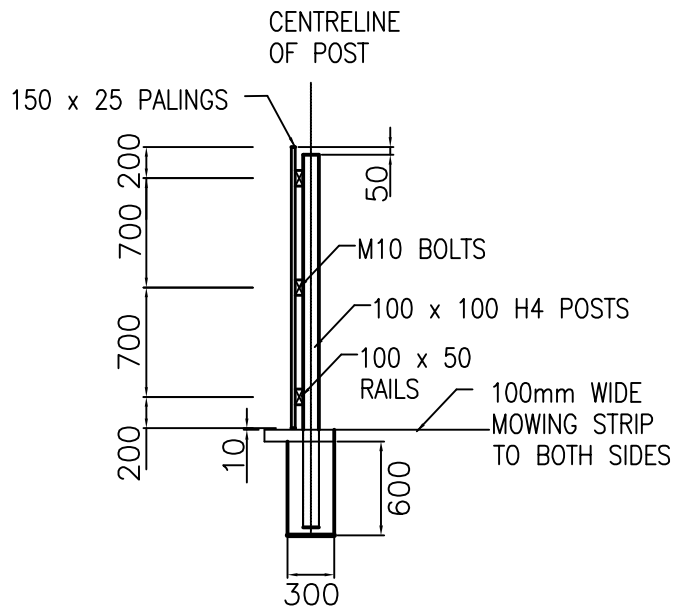

SECTION
NTS

NOTES

1. PALINGS TO BE ON PUBLIC ACCESS SIDE OF FENCE.
2. ALL NUTS, BOLTS NAILS AND WASHERS TO BE GALVANISED.
3. ALL TIMBER PALINGS AND RAILS TO BE H3 TREATED.
4. ALL POSTS TO BE H4 TREATED.
5. FENCE CAP OPTIONAL AT NEIGHBOURS EXPENSE.

**NELSON
CITY
COUNCIL**

CLOSE BOARD TIMBER FENCE

ASSET MANAGEMENT DIVISION

APPROVED

MANAGER BUSINESS & COMMUNITY ASSETS

12/09/2001

DATE

PLAN No.

21/315

SHEET 1

IF PLAQUE IS FITTED IT IS TO BE SET INTO THE CENTRE OF THE TOP BOARD SO THAT THE FRONT OF THE PLAQUE IS FLUSH.

LENGTH OF SEAT IS 1.8m WITH PIPE LEGS 300mm IN FROM EACH END.

CAP EACH END OF GALVANISED PIPE. PIPE IS 900mm LONG. BEND TO 100°.

EXCESS THREAD TO BE TRIMMED OFF AND ENDS PENNED OVER OR LIGHTLY WELDED TO REMOVE SHARP EDGES AND PREVENT REMOVAL.

120mm RADIUS

WELDS TO BE WIRE BRUSHED AND PAINTED WITH GREY ANTI RUST PRIMER PAINT SUCH AS COLDGALV.

CONCRETE PAD
2.2 x 1.0 x 0.1 STEEL
FLOAT FINISH WITH
EDGING TROWEL FINISH
AROUND OUTSIDE EDGE.
PAD TO HAVE 3%
CROSSFALL TO
DISPERSE RAIN.

40mm NOMINAL
GALVANISED PIPE 740mm
LONG. PRESS AND SHAPE
TO FIT AT 93° AND WELD
WITH 6mm FILLET ALL
ROUND.

10mm Ø GALVANISED
COACH BOLTS. ROUND
HEAD.

DRESSED EX 200 x 50
No.1 H3 TREATED PINE
POPLAR OR MACROCARPA.

DRESSED 150 x 50 No. 1
H3 TREATED PINE.
POPLAR OR MACROCARPA

TIMBER TO BE PAINTED
WITH RESENE
LUMBERSIDER "DOC
GREEN".

CHAMFER AND SAND ALL
TOP EDGES.

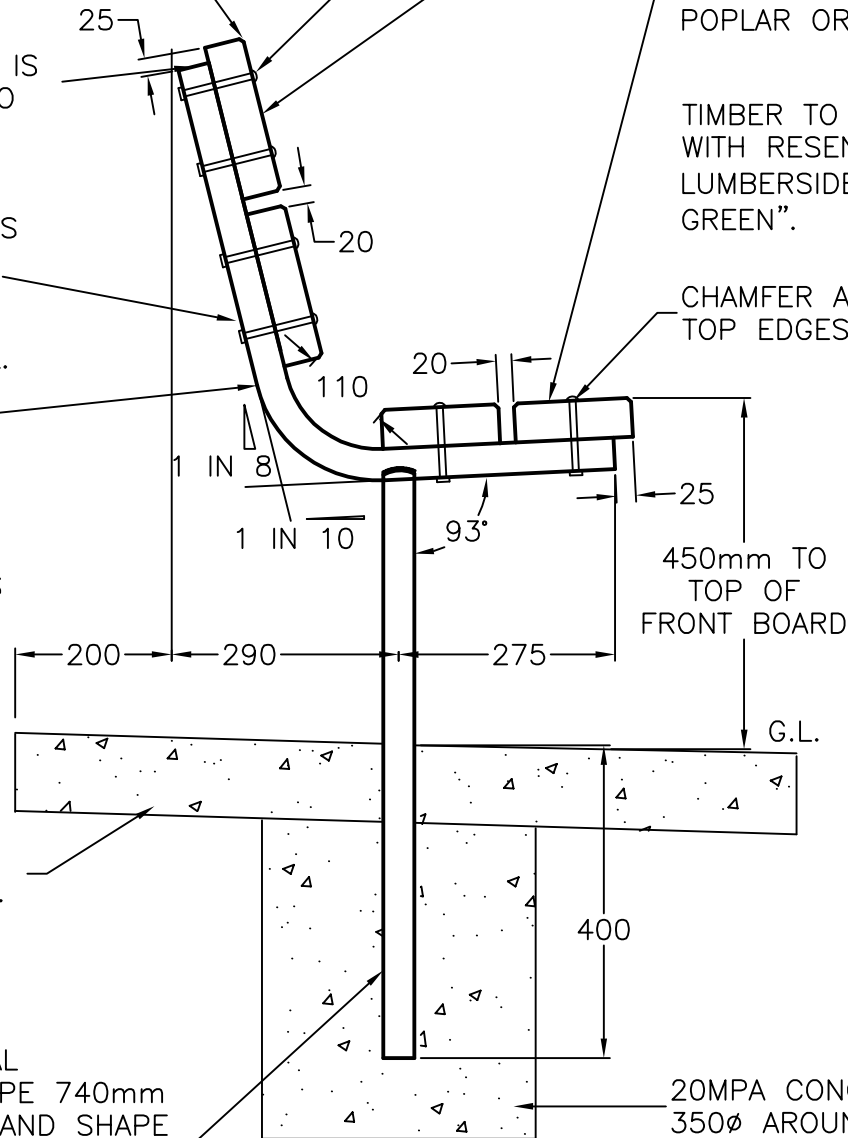

STEEL LEGS ARE TO BE BENT IN A HYDRAULIC PIPE BENDER WITH SUITABLE FORMER AND WELDED IN A JIG TO ENSURE UNIFORMITY.

NTS

**NELSON
CITY
COUNCIL**

STANDARD PARK BENCH

ASSET MANAGEMENT DIVISION

APPROVED

John Reell

12/09/2001

MANAGER BUSINESS & COMMUNITY ASSETS DATE

PLAN No.

21/316

SHEET 1 OF 1

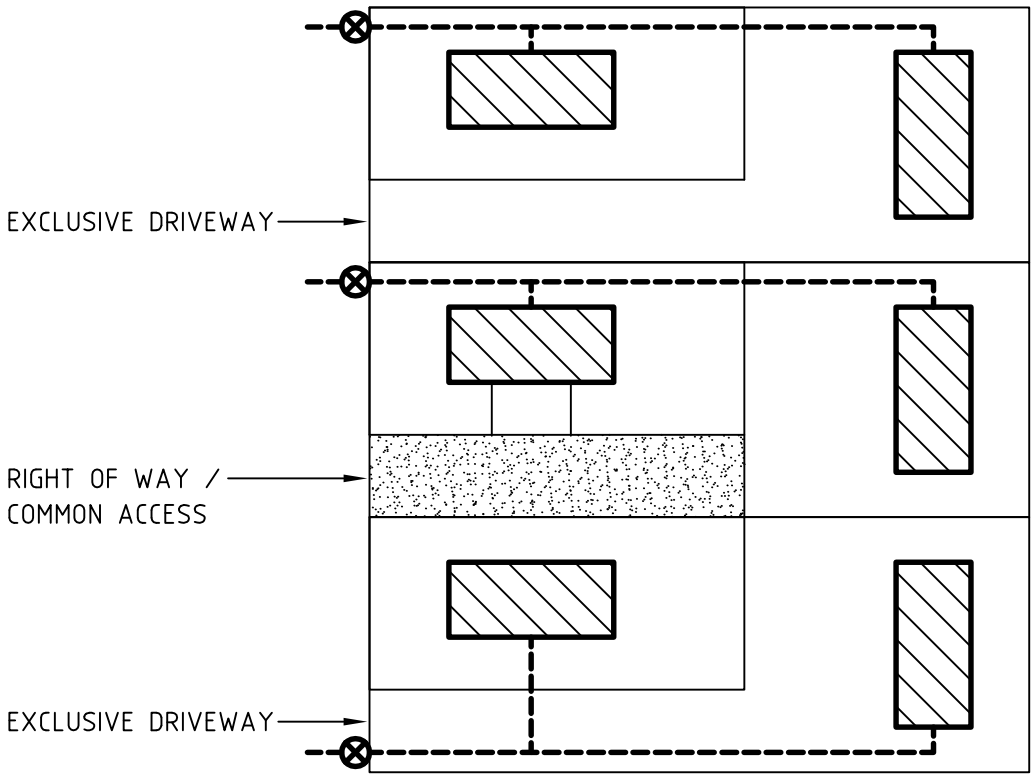

NOT APPROVED

NOT APPROVED

NOT APPROVED

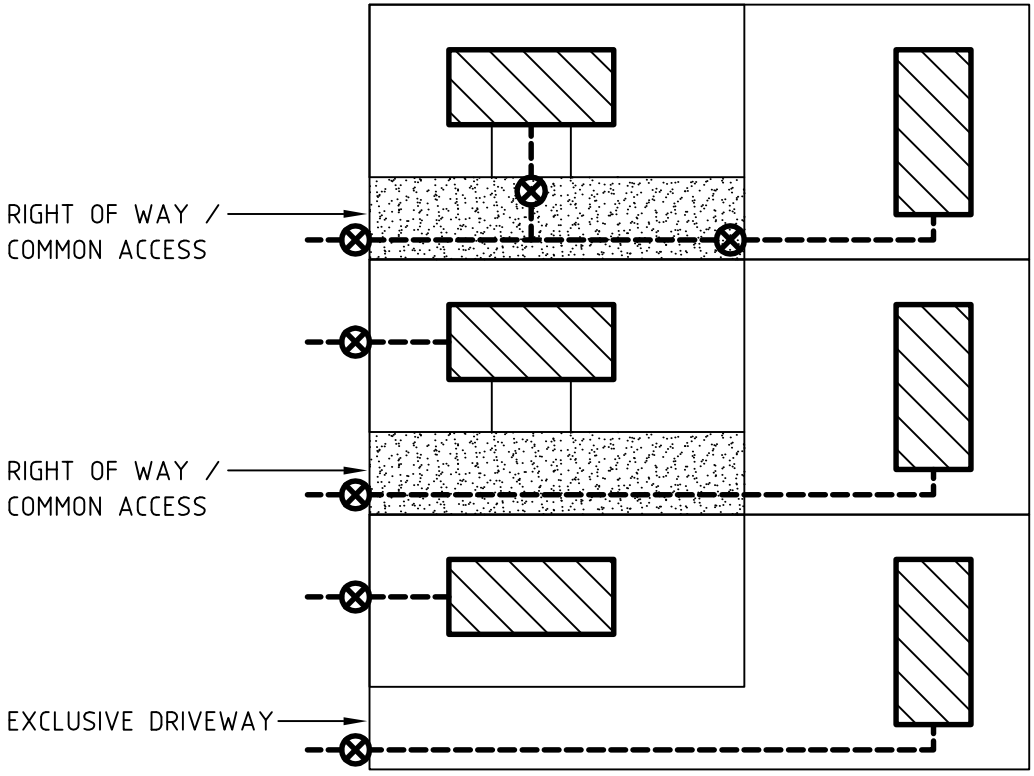

APPROVED

APPROVED

APPROVED

⊗ DENOTES POSITION OF WATER METER ASSEMBLY

**NELSON
CITY
COUNCIL**

**WATER CONNECTION POLICY
SUBDIVISION & CROSS LEASE**

ASSET MANAGEMENT DIVISION

APPROVED

MANAGER INFRASTRUCTURAL ASSETS

Jan. 2003

DATE

PLAN No.

21/400

SHEET 1

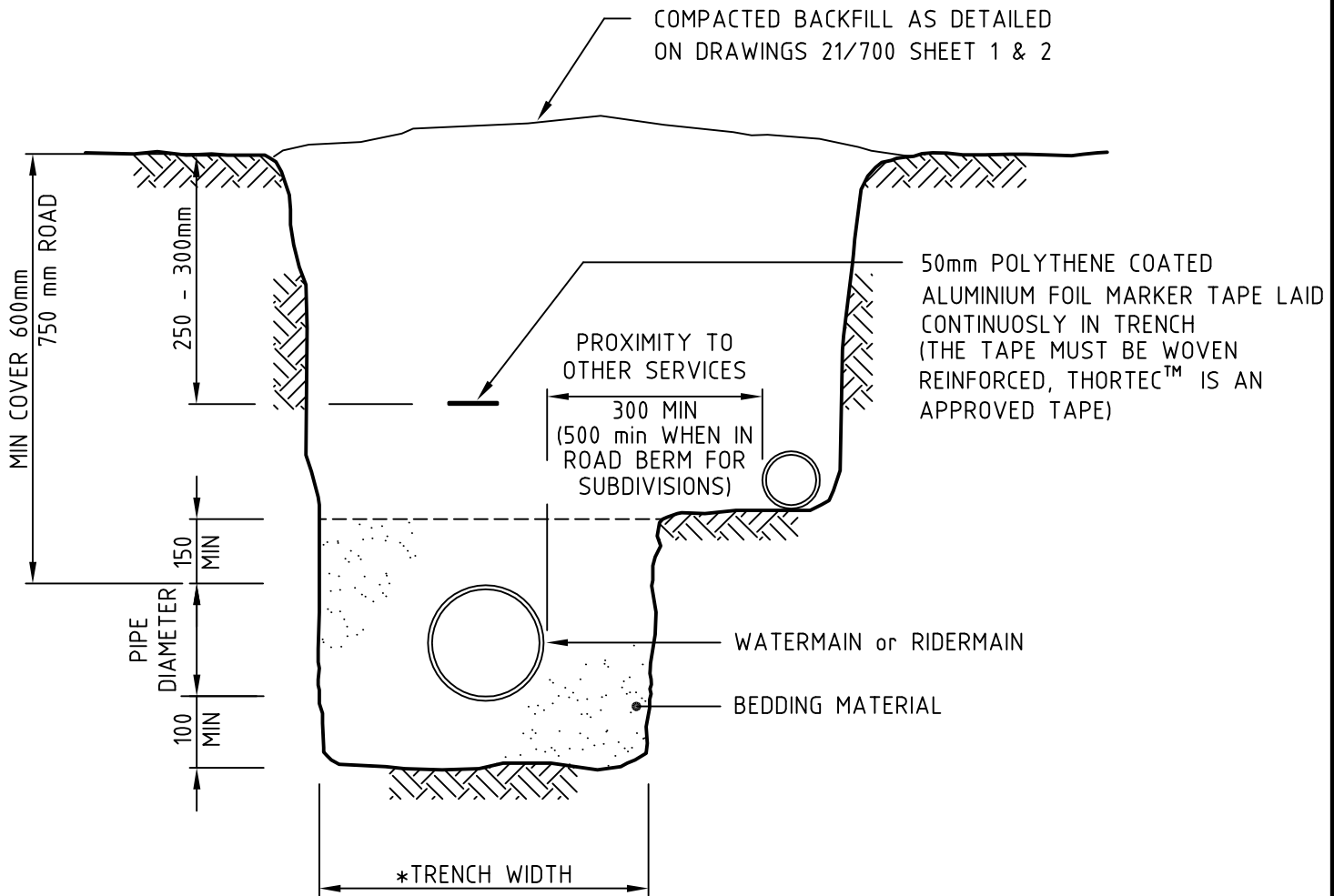

***TRENCH WIDTH**

| NOMINAL DIAMETER DN (mm) | MINIMUM TRENCH SIDE CLEARANCE "lc" TO AS/NZS 2566 | * MAXIMUM |
|--------------------------|---|-----------|
| UP TO 150 | 100 | 600 |
| 200 - 250 | 150 | 600 |
| 300 - 375 | 200 | 775 |

THE TRENCH WIDTH SHALL BE THE MINIMUM NECESSARY TO ADEQUATELY AND SAFELY LAY THE PIPE AND TO COMPACT THE SIDE SUPPORT ZONE

**NELSON
CITY
COUNCIL**

WATER TRENCHING REQUIREMENT

ASSET MANAGEMENT DIVISION

APPROVED

MANAGER INFRASTRUCTURAL ASSETS

Jan. 2003

DATE

PLAN No.

21/401

SHEET 1

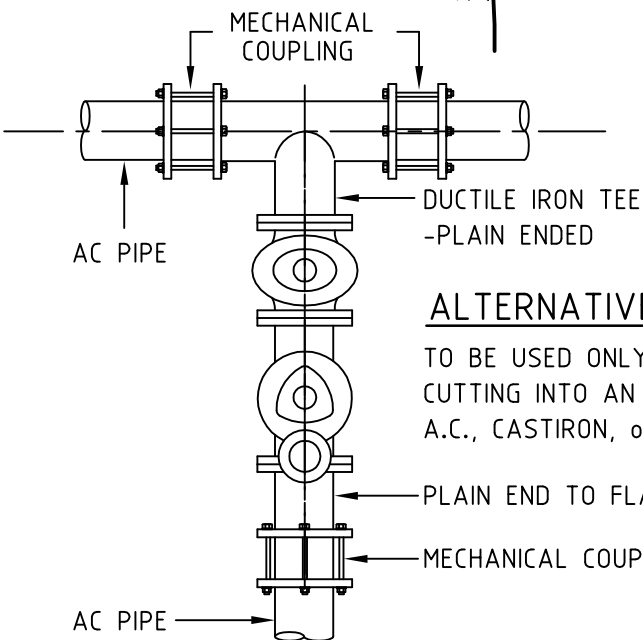
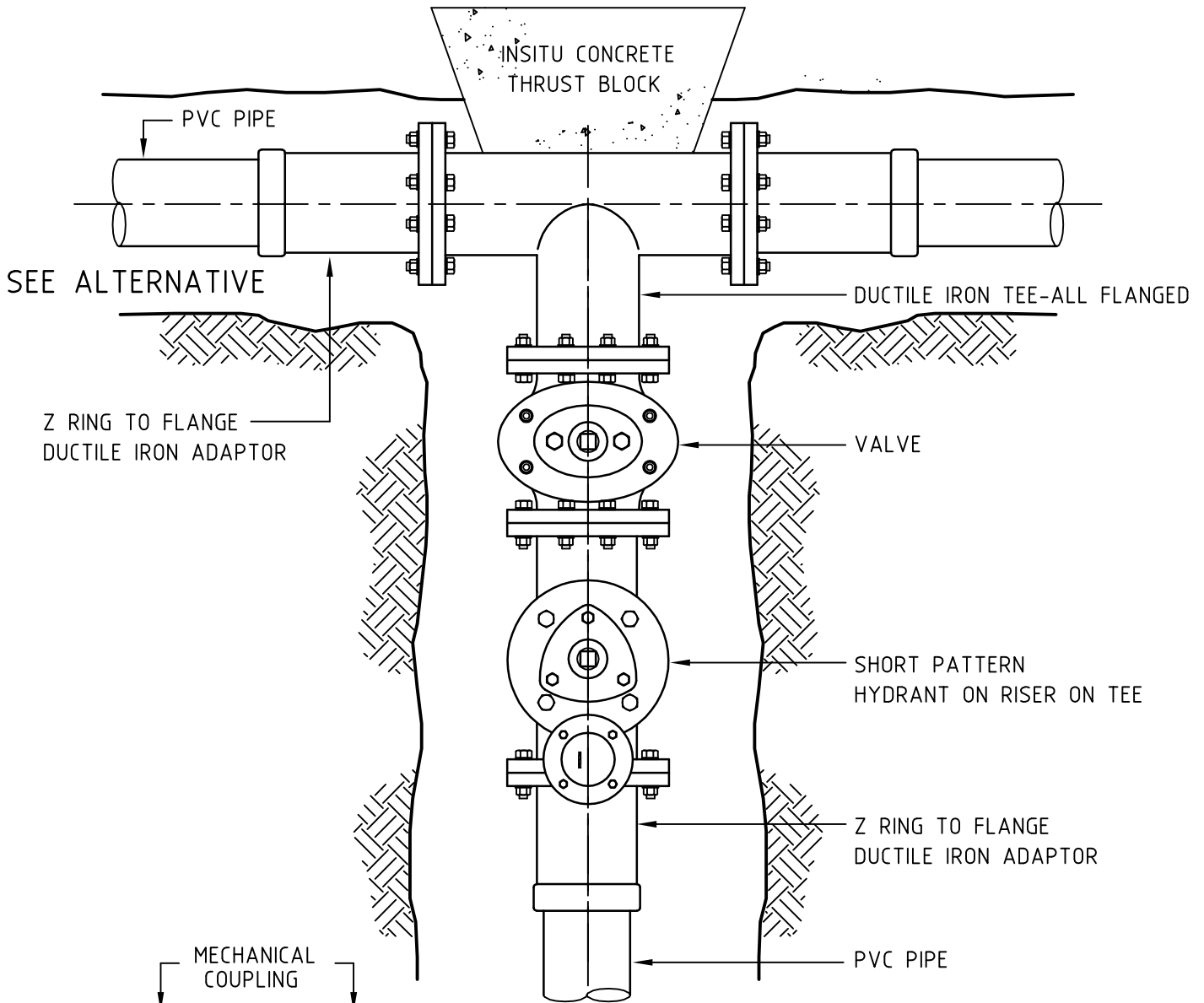

ALTERNATIVE

TO BE USED ONLY FOR CUTTING INTO AN EXISTING A.C., CASTIRON, or STEEL PIPE

ALL FITTINGS TO BS 10 TABLE E

**NELSON
CITY
COUNCIL**

WATERMAIN TEE JUNCTION DETAIL

ASSET MANAGEMENT DIVISION

APPROVED

MANAGER INFRASTRUCTURAL ASSETS

Jan. 2003

DATE

PLAN No.

21/402

SHEET 1

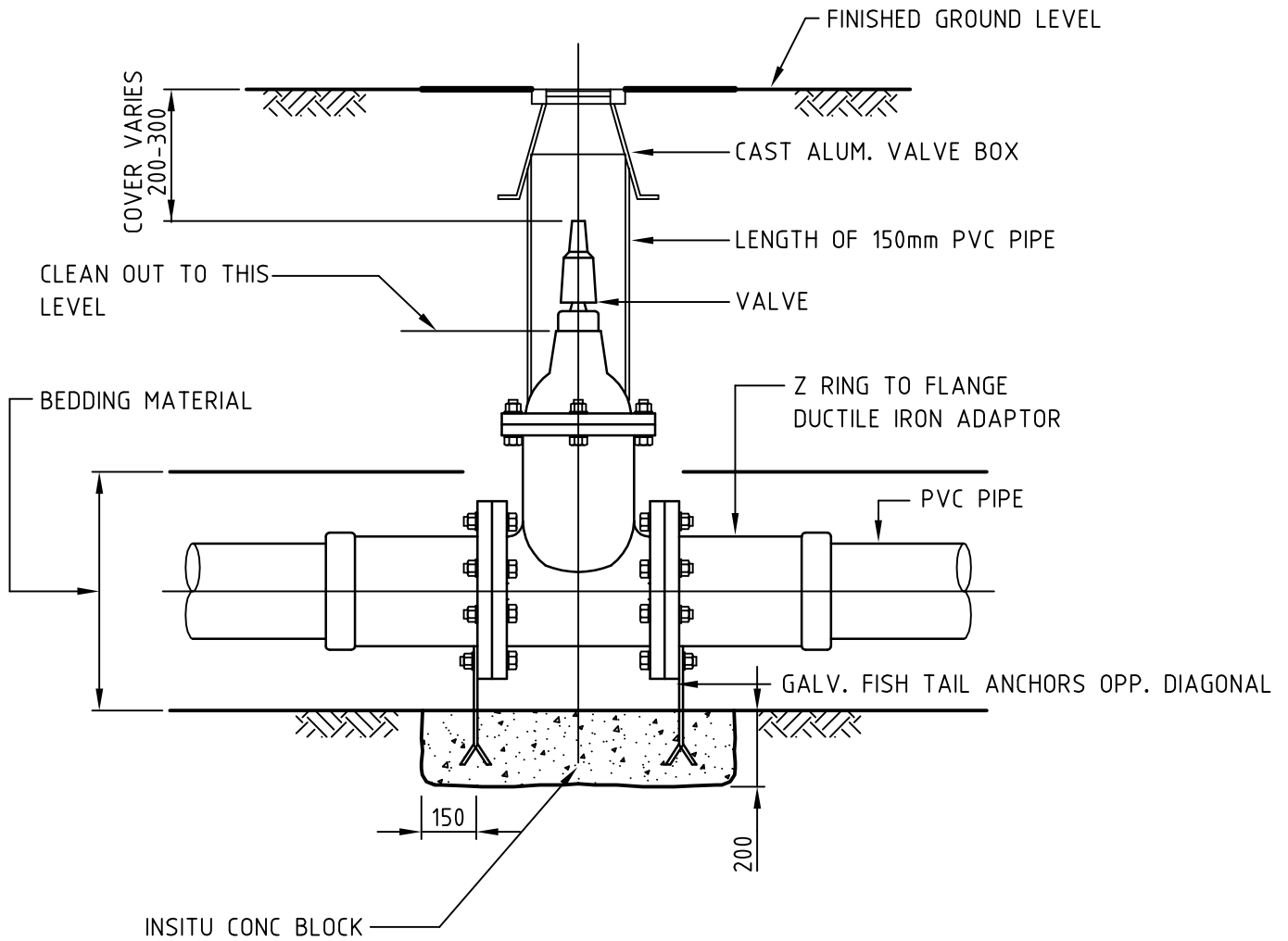

**NELSON
CITY
COUNCIL**

SLUICE VALVE INSTALLATION

ASSET MANAGEMENT DIVISION

APPROVED

MANAGER INFRASTRUCTURAL ASSETS

Jan. 2003

DATE

PLAN No.

21/403

SHEET 1

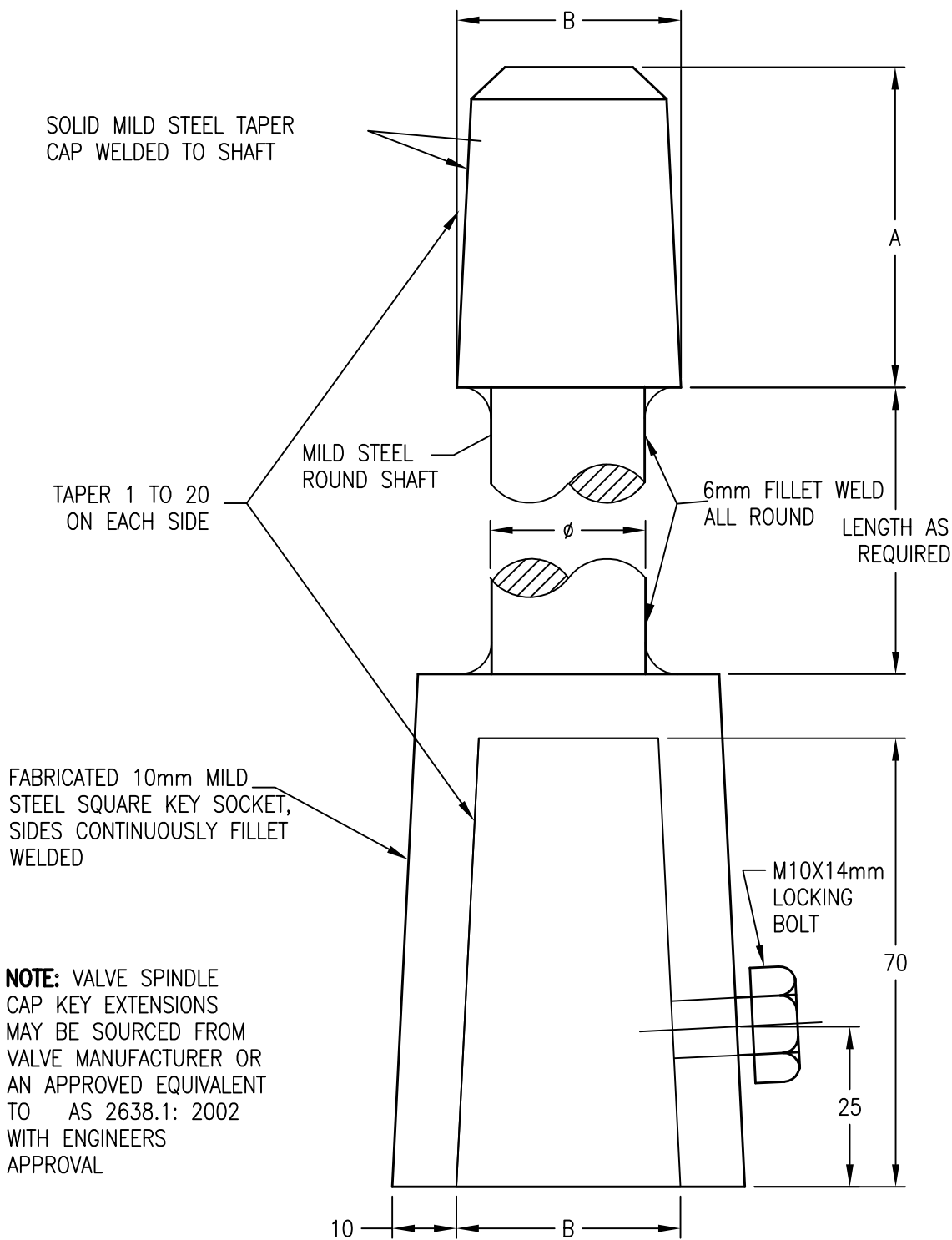

| NOMINAL SIZE OF VALVE DN mm | φ mm | LENGTH OF SQUARE ON CAP (A) mm | SQUARE ON CAP AND KEY (B) mm |
|--------------------------------|---------|-----------------------------------|---------------------------------|
| 80-150 | 24 | 50 | 35 |
| 200-900 | 32 | 57 | 35 |

**NELSON
CITY
COUNCIL**

SLUICE VALVE KEY CAP EXTENSION

ASSET MANAGEMENT DIVISION

APPROVED

MANAGER INFRASTRUCTURAL ASSETS

Jan. 2003

DATE

PLAN No.

21/403

SHEET 2

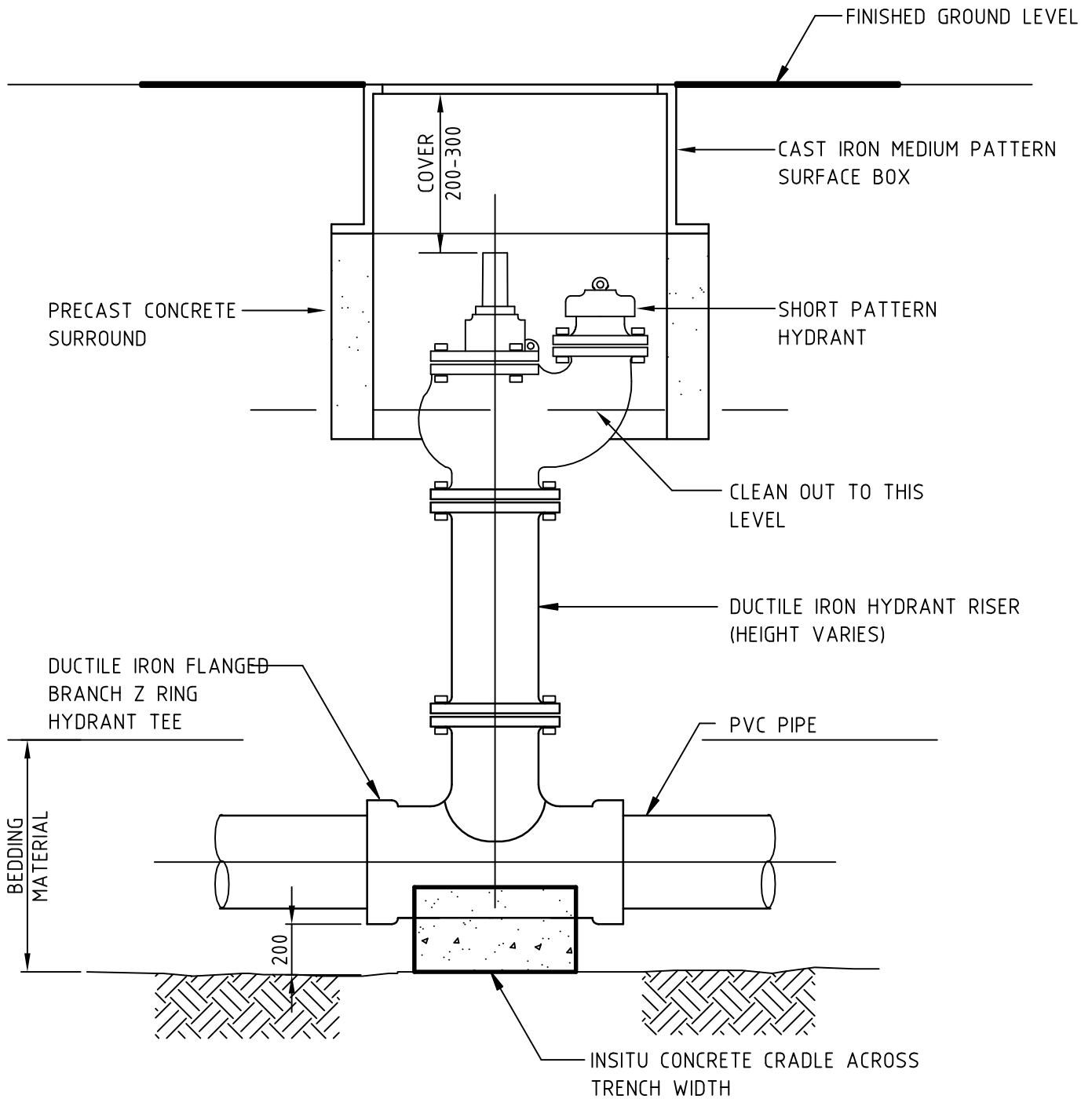

**NELSON
CITY
COUNCIL**

FIRE HYDRANT INSTALLATION

ASSET MANAGEMENT DIVISION

APPROVED

MANAGER INFRASTRUCTURAL ASSETS

Jan. 2003

DATE

PLAN No.

21/404

SHEET 1

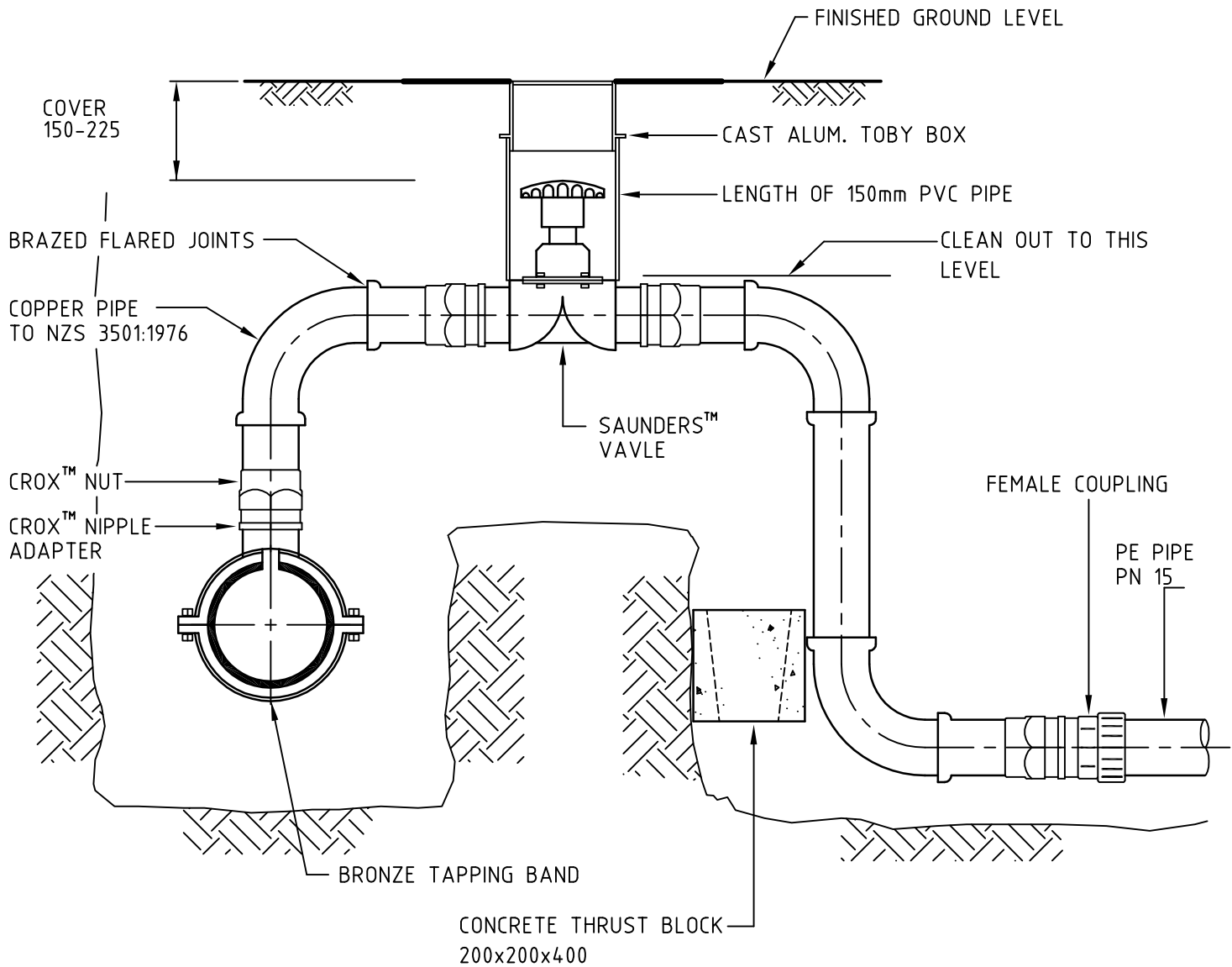

NOTE:

THIS DIAGRAM APPLIES TO THE SITUATION WHERE THE MAIN IS LOCATED IN THE FOOTPATH OR BERM WHERE THE MAIN IS LOCATED IN THE ROAD THE LAYOUT SHALL BE MODIFIED SO THAT THE SAUNDERS VALVE IS LOCATED IN THE FOOTPATH OR BERM

ALTERNATIVE

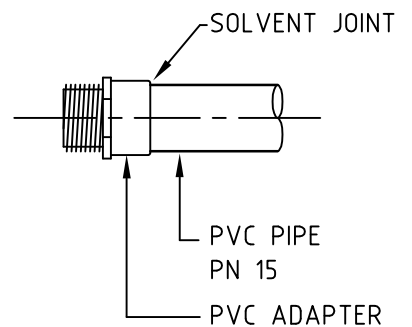

**NELSON
CITY
COUNCIL**

RIDERMAIN CONNECTION DETAIL

ASSET MANAGEMENT DIVISION

APPROVED

MANAGER INFRASTRUCTURAL ASSETS

Jan. 2003

DATE

PLAN No.

21/405

SHEET 1

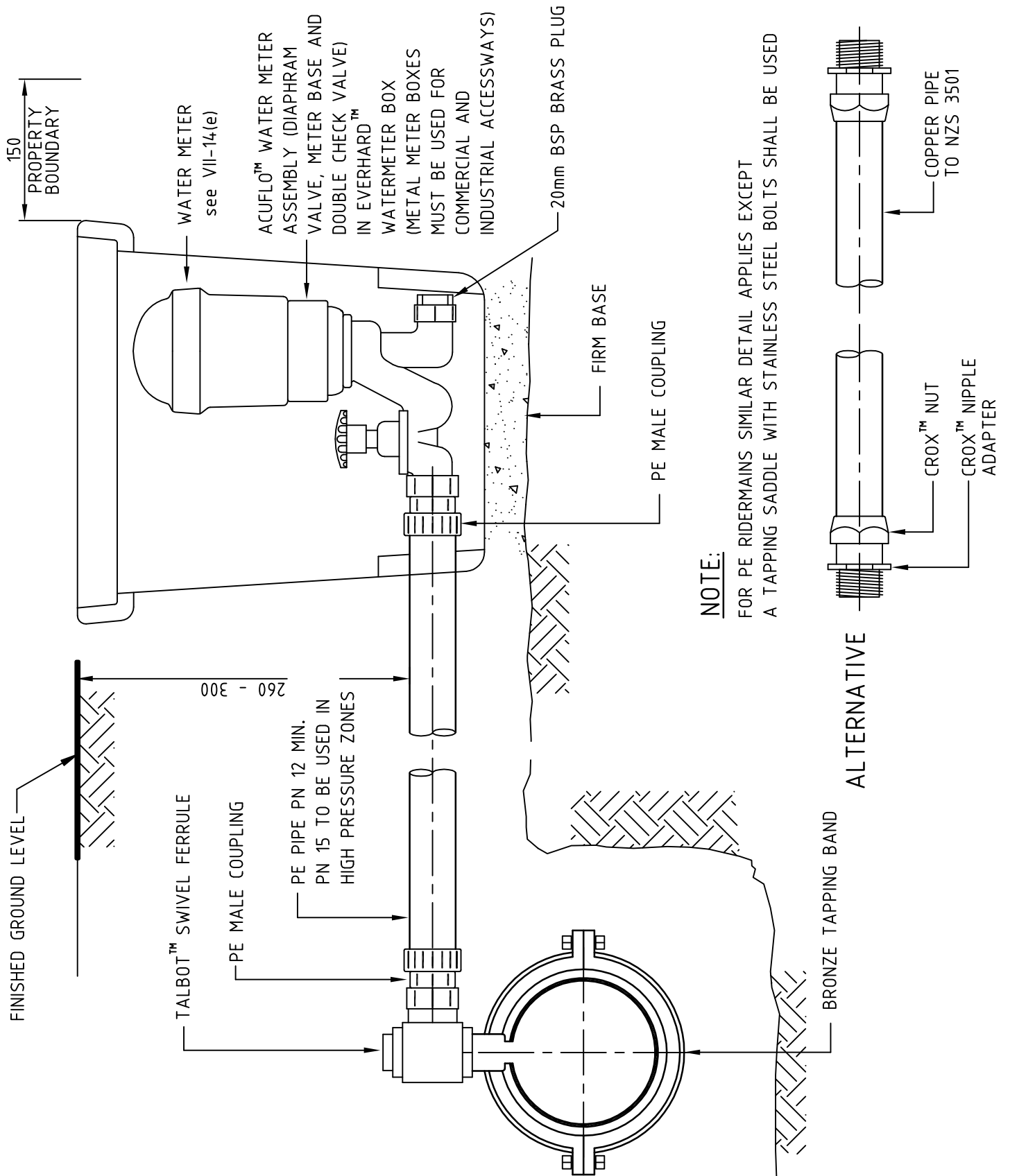

**NELSON
CITY
COUNCIL**

**WATERMAIN LATERAL FOR PROPERTY
CONNECTION**

ASSET MANAGEMENT DIVISION

APPROVED

MANAGER INFRASTRUCTURAL ASSETS

Jan. 2003

DATE

PLAN No.

21/406

SHEET 1

FLANGES FOR PIPES, VALVES & FITTINGS TO AS 2129 - 1978

SURFACE PREPARATION

WIRE BRUSH LOOSE DIRT AND RUST FROM THE FLANGE AND ADJACENT PIPE, IF APPROPRIATE AND 100mm ONTO ANY SHOP COATING. ENSURE ALL SURFACES ARE CLEAN
DENSO PRIMER CAN BE APPLIED TO MOIST OR DAMP SURFACES, BUT VERY WET SURFACES SHOULD BE DRIED

PRIMING

APPLY DENSO PRIMER TO ALL METAL SURFACES WHERE POSSIBLE, PROTECT NUTS AND BOLTS BY DIPPING IN DENSO PRIMER BEFORE ASSEMBLY

FILLING

FLANGES TO TABLES A & D MOULD DENSO MASTIC OVER THE HEADS OF BOLTS, NUTS AND SCREW THREADS WITH A MINIMUM COVERAGE OF 5mm TAPER ONTO FLANGE FACE TO PROVIDE A SUITABLE CONTOUR FOR TAPE WRAPPING FLANGES TO TABLES E DUE TO THE INCREASED NUMBER OF BOLTS IN THIS CASE, IT IS NECESSARY TO USE DENSO MASTIC BETWEEN INDIVIDUAL BOLTS AND NUTS TO PROVIDE A SUITABLE CONTOUR FOR TAPING

WRAPPING

APPLY ONE COMPLETE TURN OF DENSO TAPE CIRCUMFERENTIALLY AROUND FLANGE WITH ONE SIDE AGAINST THE EDGE OF THE THE FLANGE. OVERLAP ABOUT 80mm. MOULD THE OVERHANGING TAPE OVER THE MASTIC. APPLY A SECOND TURN OF TAPE TO PROVIDE A DOUBLE THICKNESS AROUND THE FLANGE AND COVER THE OPPOSITE SIDE FOR FLANGES ON SHOP COATED LINES, SPIRALLY WRAP DENSO TAPE FROM THE PROTECTED FLANGE AND 100mm ONTO THE SHOP COATING ON EITHER SIDE.

OVERWRAPPING

ENVELOPE WITH DENSO MP/HD TAPE

PRIME NUTS AND BOLTS BEFORE ASSEMBLY WHERE POSSIBLE
THIS AREA MAY BE FILLED WITH MASTIC ON SMALL DIAMETERS

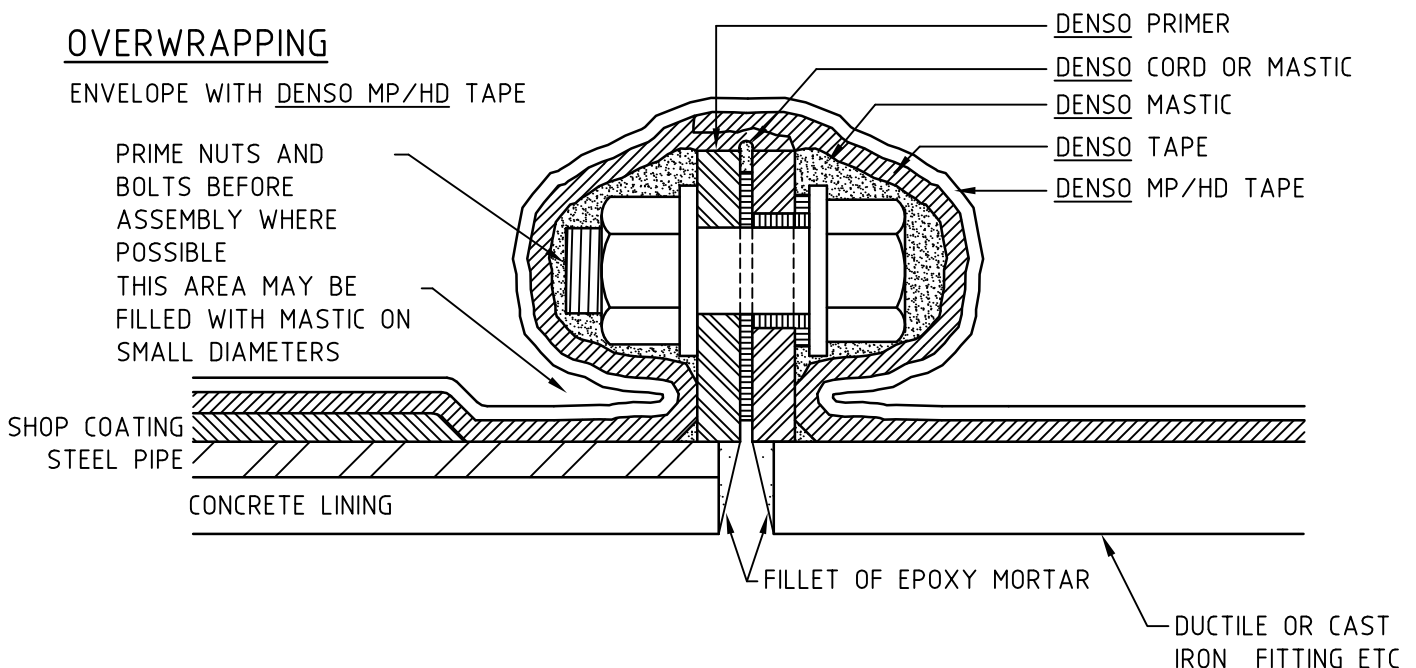

**NELSON
CITY
COUNCIL**

CORROSION PROTECTION FOR FLANGES

ASSET MANAGEMENT DIVISION

APPROVED

MANAGER INFRASTRUCTURAL ASSETS

Jan. 2003

DATE

PLAN No.

21/407

SHEET 1

All Unrestrained Mechanical Couplings shall be wrapped as detailed below where materials other than 316 stainless steel and coatings to AS/NZS 4158 are used.

SURFACE PREPARATION

WIRE BRUSH LOOSE DIRT AND LOOSE RUST FROM THE JOINT AND ADJACENT PIPE.

DENSO PRIMER CAN BE APPLIED TO MOIST OR DAMP SURFACES, BUT VERY WET SURFACES SHOULD BE DRIED

PRIMING

APPLY DENSO PRIMER TO ALL METAL SURFACES

WHERE POSSIBLE, PROTECT NUTS AND BOLTS BY DIPPING IN DENSO PRIMER BEFORE ASSEMBLY

FILLING

FILL BETWEEN BOLTS AND SLEEVE, AND BOLTS TO TOP FLANGES WITH DENSO MASTIC

COVER BOLT HEADS, NUTS AND ANY PROTRUDING THREAD WITH DENSO MASTIC

WRAPPING

WHERE A SERVICE TAPPING MAY BE INCLUDED WITH THE UNRESTRAINED MECHANICAL COUPLING, APPLY ONE COMPLETE TURN OF DENSO TAPE AROUND THE JOINT LAPPING BOTH ENDS ONTO THE SERVICE PIPE.

APPLY DENSO TAPE AROUND ONE END OF JOINT WITH AN END LAP OF 80mm. MOULD THE TAPE FROM THE HIGHEST POINT ON THE FLANGE WORKING DOWN TO EXCLUDE AIR BUBBLES.

APPLY ANOTHER COMPLETE TURN OF TAPE SIMILARLY WITH MINIMUM SIDE LAP OF 20mm.

MOULD THE TAPE AROUND THE MASTIC COVERED BOLT HEADS, E.T.C.

OVERWRAPPING

ENVELOPE WITH DENSO MP/HD TAPE

NOTE

FOR CONCRETE LINED STEEL PIPES
DENSO SYSTEM TO OVER LAP
ONTO SHOP WRAPPING AS IN:
FLANGE DETAIL 21/407 SHT 1

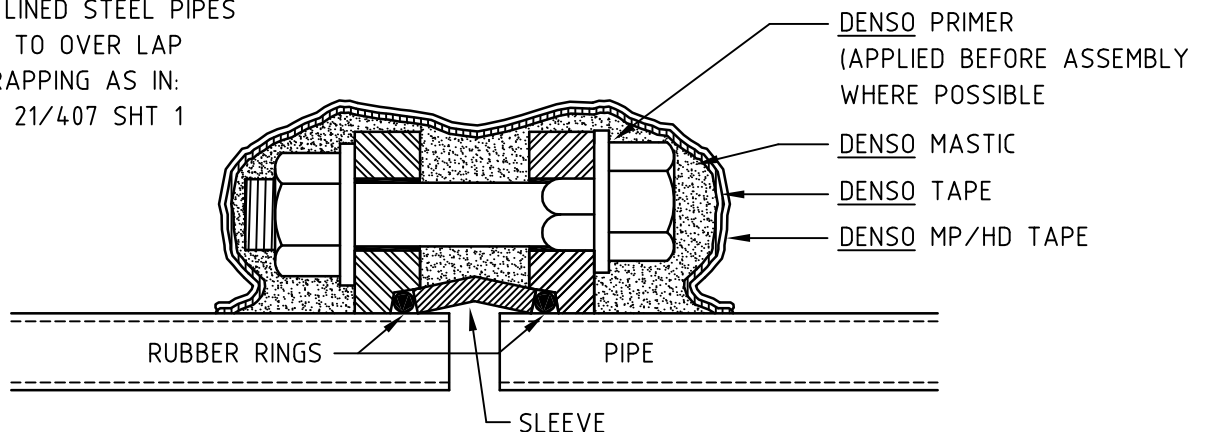

**NELSON
CITY
COUNCIL**

CORROSION PROTECTION FOR UNRESTRAINED MECHANICAL COUPLINGS

ASSET MANAGEMENT DIVISION

APPROVED

MANAGER INFRASTRUCTURAL ASSETS

Jan. 2003

DATE

PLAN No.

21/407

SHEET 2

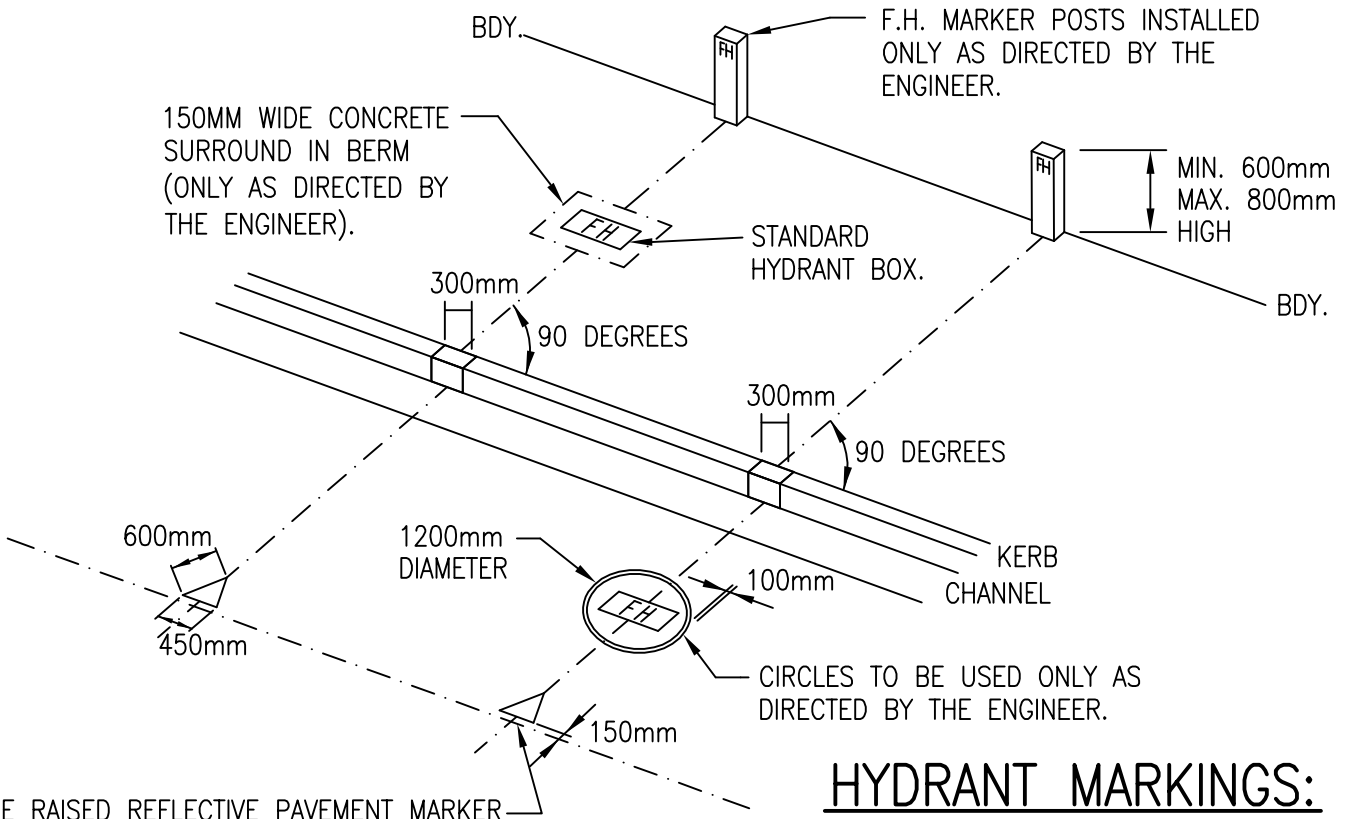

HYDRANT MARKINGS:
NOT TO SCALE

BLUE RAISED REFLECTIVE PAVEMENT MARKER AT OR CLOSE TO, AND ON THE APPROPRIATE SIDE OF, THE CENTRE OF THE ROADWAY AT OR NEAR THE BASE OF THE YELLOW TRIANGLE MARKER.

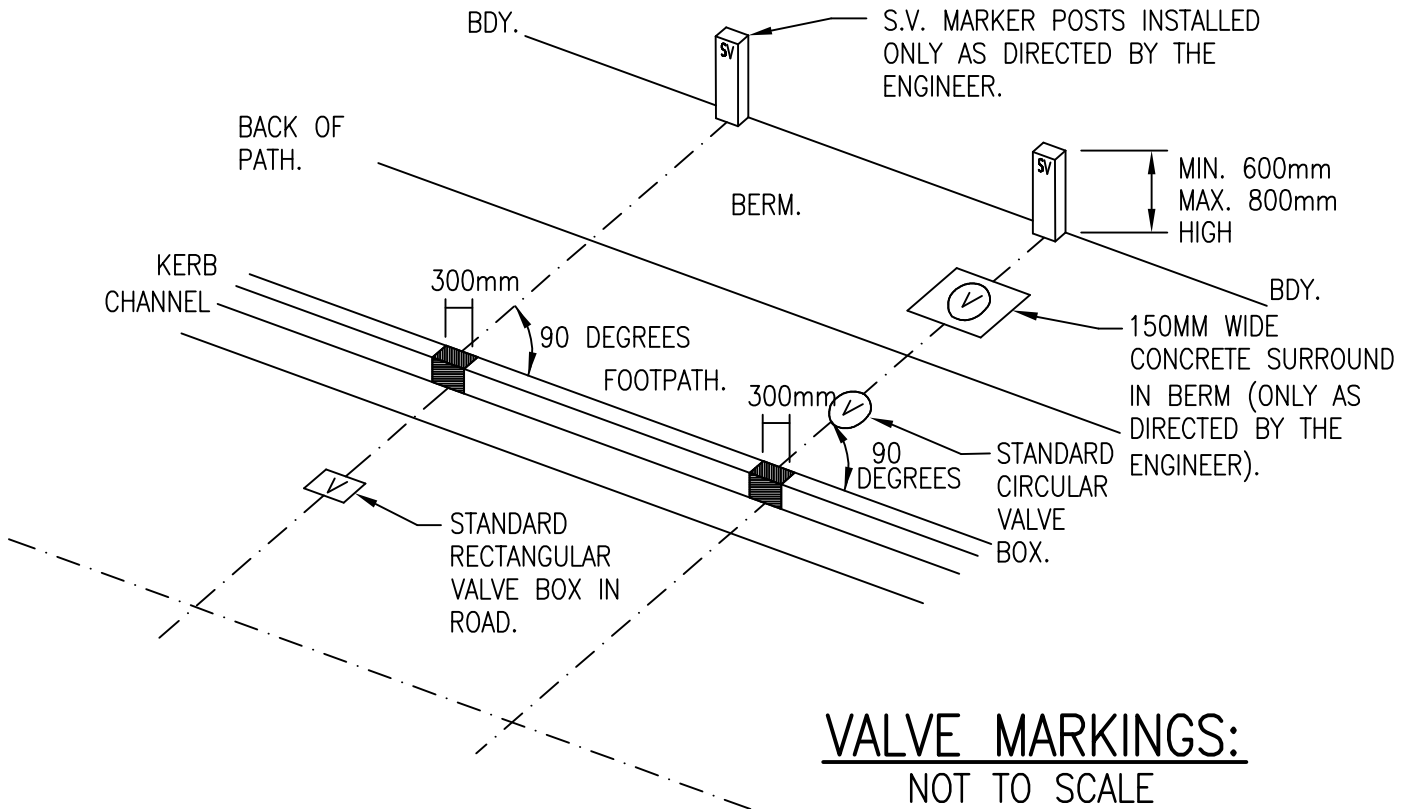

VALVE MARKINGS:
NOT TO SCALE

NELSON CITY COUNCIL

STANDARD VALVE & HYDRANT ROAD MARKINGS

ASSET MANAGEMENT DIVISION

APPROVED

MANAGER INFRASTRUCTURAL ASSETS

Jan. 2003









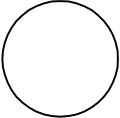

DATE

PLAN No.

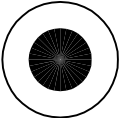
21/408

SHEET 1

VALVE CODING:

| | | | |
|---|--|--|-------------------------|
|  | YELLOW |  | RED |
|  | LOW LEVEL |  | AIR VALVE |
|  | HIGH LEVEL |  | PRESSURE REDUCING VALVE |
|  | SHUT |  | NON RETURN VALVE |
|  | BYPASS |  | SCOUR VALVE |
|  | LEFT HAND VALVE (ie. ANTICLOCKWISE TO OPEN) | | |

NOTES:

1. PAINT USED FOR ALL ROAD MARKINGS SHALL BE NRB "ROAD MARKING PAINT" (YELLOW – NRB M/7-Y) AND PLASTI-KOTE INDUSTRIAL TRAFFIC PAINT "6639N RED" OR EQUIVALENT.
2. ALL HYDRANT KERB MARKINGS SHALL BE YELLOW AND ALL VALVE KERB MARKINGS SHALL BE RED.

**NELSON
CITY
COUNCIL**

**STANDARD VALVE & HYDRANT ROAD
MARKINGS**

ASSET MANAGEMENT DIVISION
 APPROVED 

 MANAGER INFRASTRUCTURAL ASSETS Jan. 2003
 DATE

PLAN No.
21/408
 SHEET 2

BOUNDARY OR EDGE OF LANDSCAPING STRIP

600

CENTRELINE OF CABLE

NOTE

ALL DIMENSIONS ARE MINIMUM ONLY

WHEN TRENCH IS A SHARED TRENCH THE DIMENSIONS WILL HAVE TO BE DEEPENED AND/OR WIDENED TO ACCOMMODATE EACH TYPE OF SERVICE.

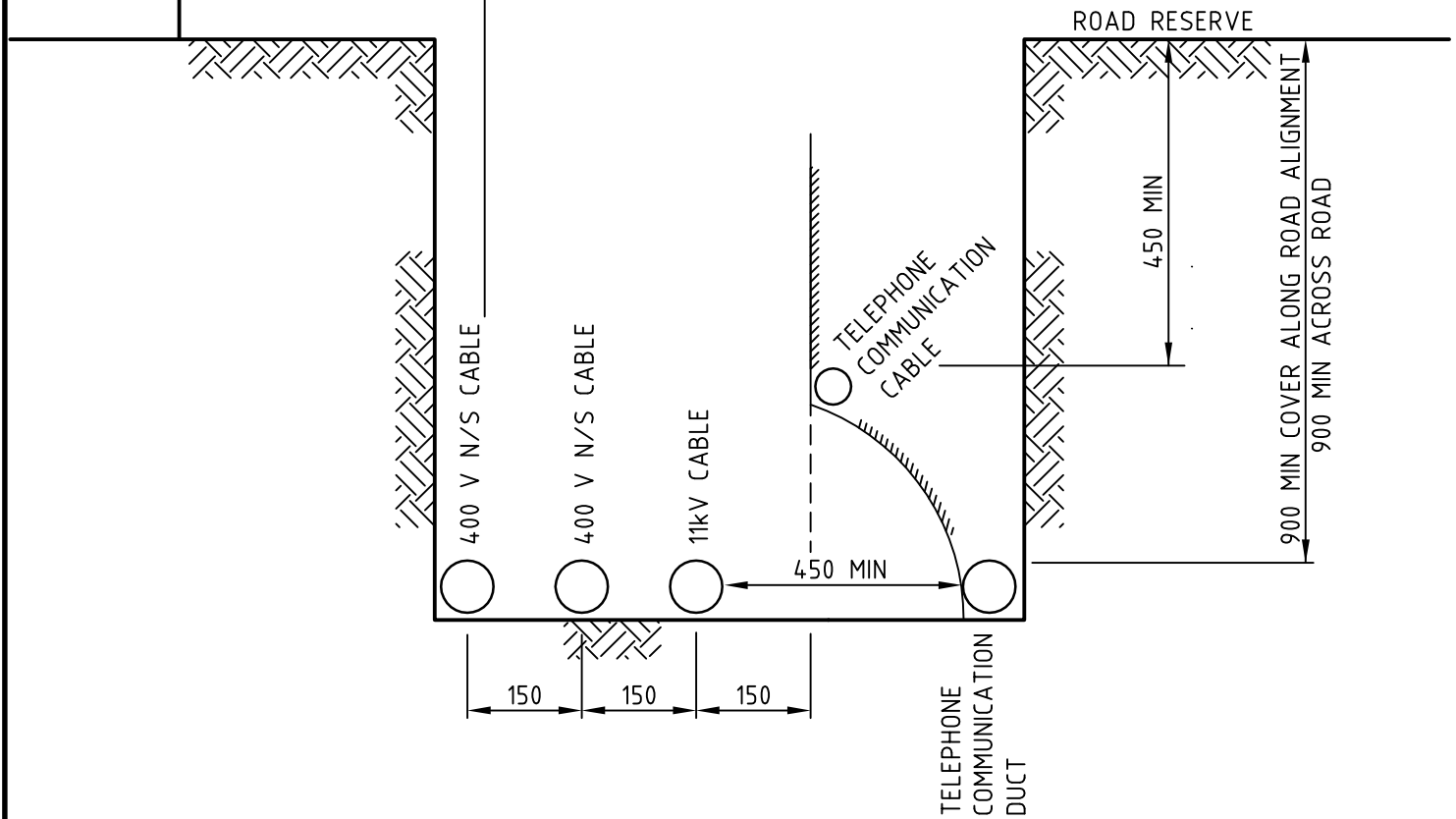

**NELSON
CITY
COUNCIL**

**ELECTRICAL RETICULATION ROAD RESERVE
(DEPTH, LOCATION & CLEARANCES)**

ASSET MANAGEMENT DIVISION

APPROVED

MANAGER INFRASTRUCTURAL ASSETS

Jan. 2003

DATE

PLAN No.

21/500

SHEET 1

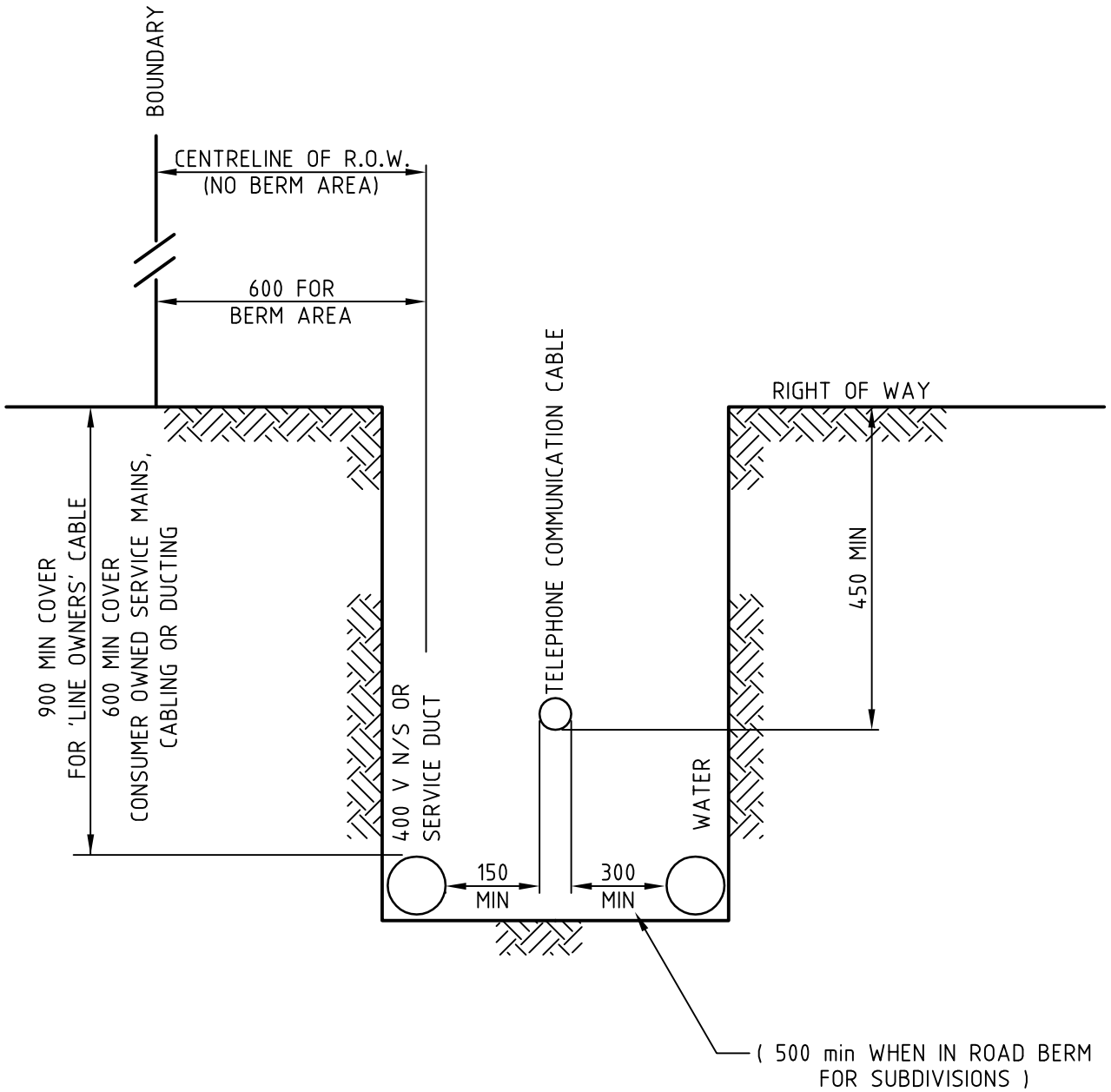

**NELSON
CITY
COUNCIL**

**ELECTRICAL RETICULATION RIGHT OF WAY
(DEPTH, LOCATION & CLEARANCES)**

ASSET MANAGEMENT DIVISION

APPROVED

MANAGER INFRASTRUCTURAL ASSETS

Jan. 2003

DATE

PLAN No.

21/500

SHEET 2

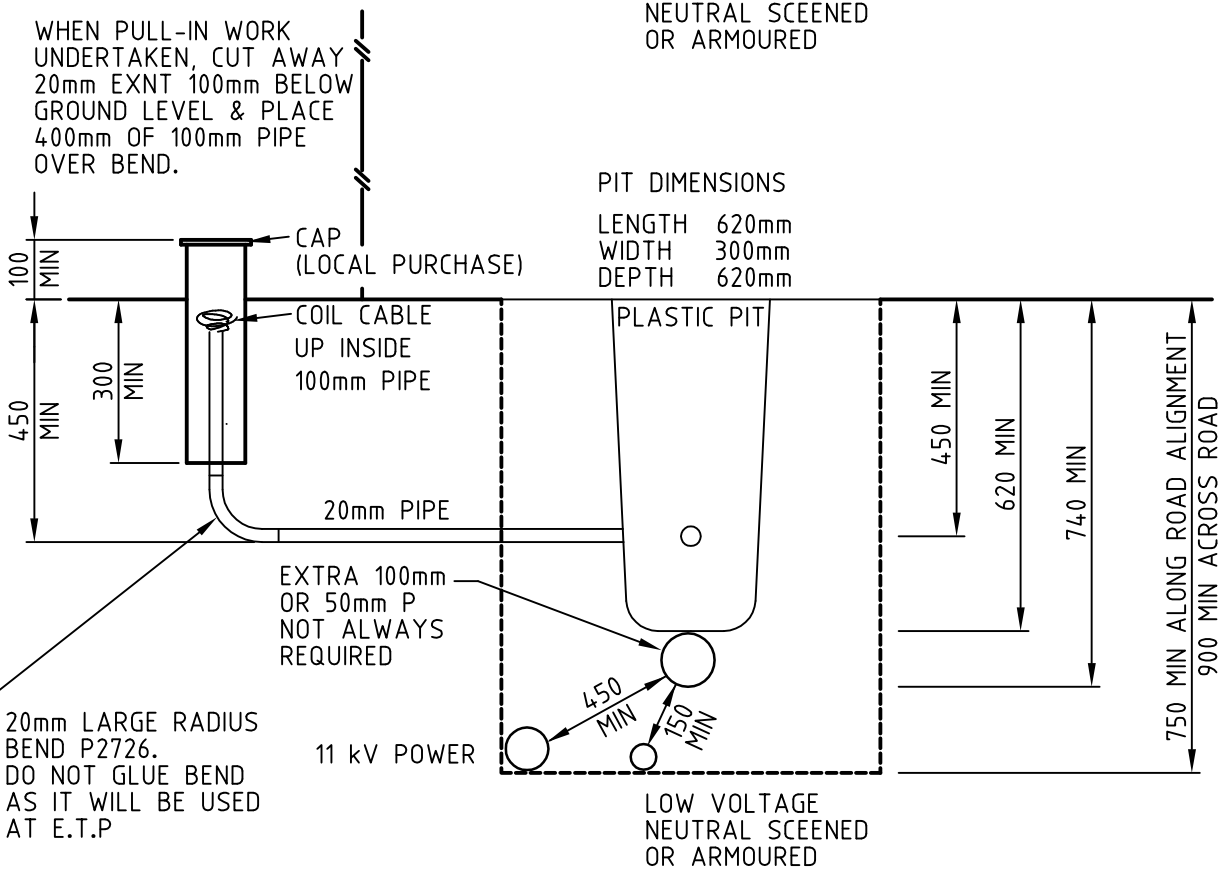
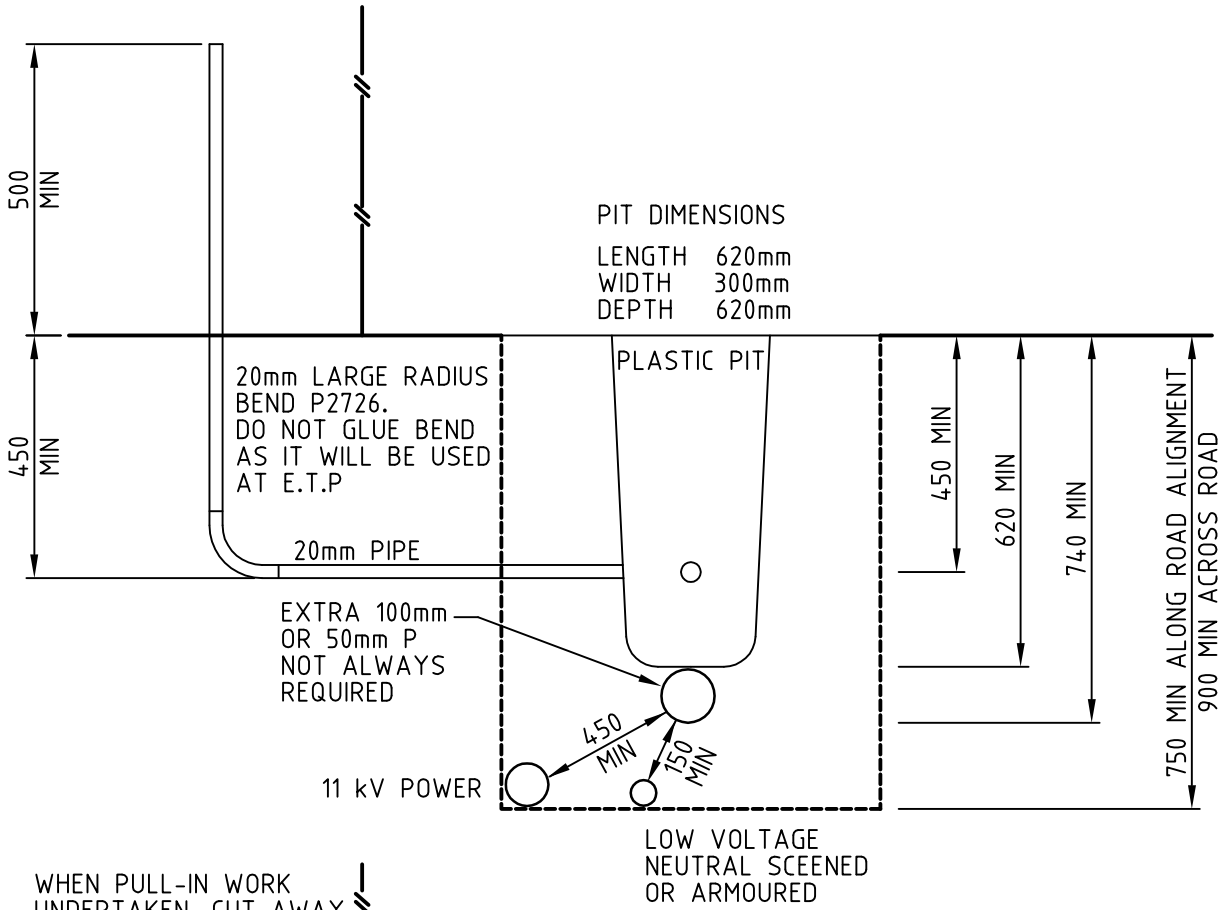

**NELSON
 CITY
 COUNCIL**

**TELEPHONE COMMUNICATION SERVICE
 PIT DEPTHS & CLEARANCES**

ASSET MANAGEMENT DIVISION

APPROVED 

MANAGER INFRASTRUCTURAL ASSETS

Jan. 2003

DATE

PLAN No.

21/600

SHEET 1

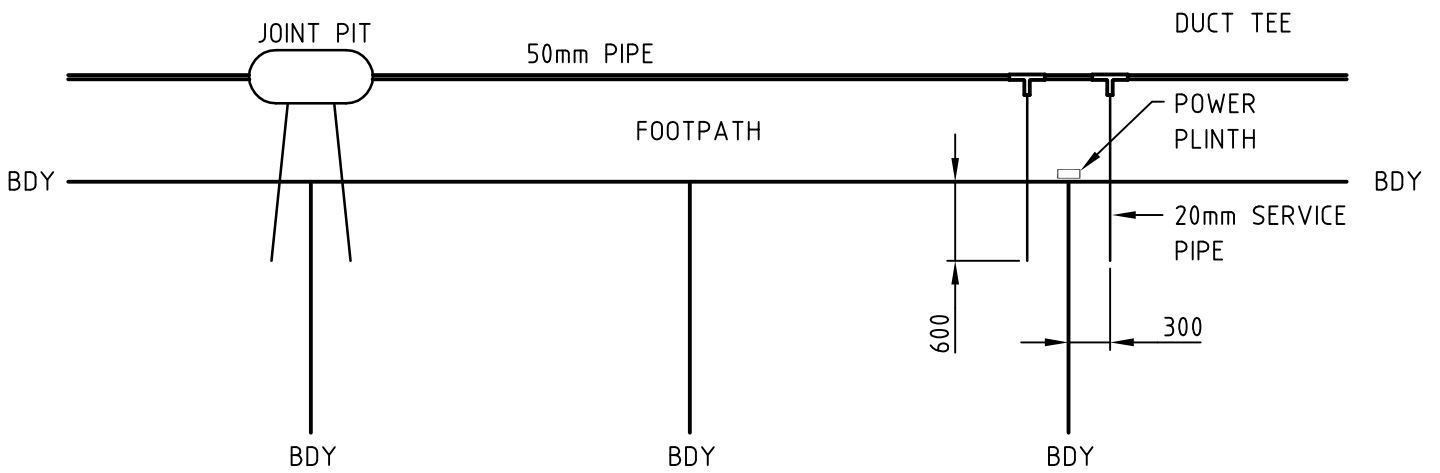

**NELSON
CITY
COUNCIL**

**TELEPHONE COMMUNICATION
RETICULATION LAYOUT**

ASSET MANAGEMENT DIVISION

APPROVED

.....
MANAGER INFRASTRUCTURAL ASSETS

Jan. 2003

.....
DATE

PLAN No.

21/601

SHEET 1

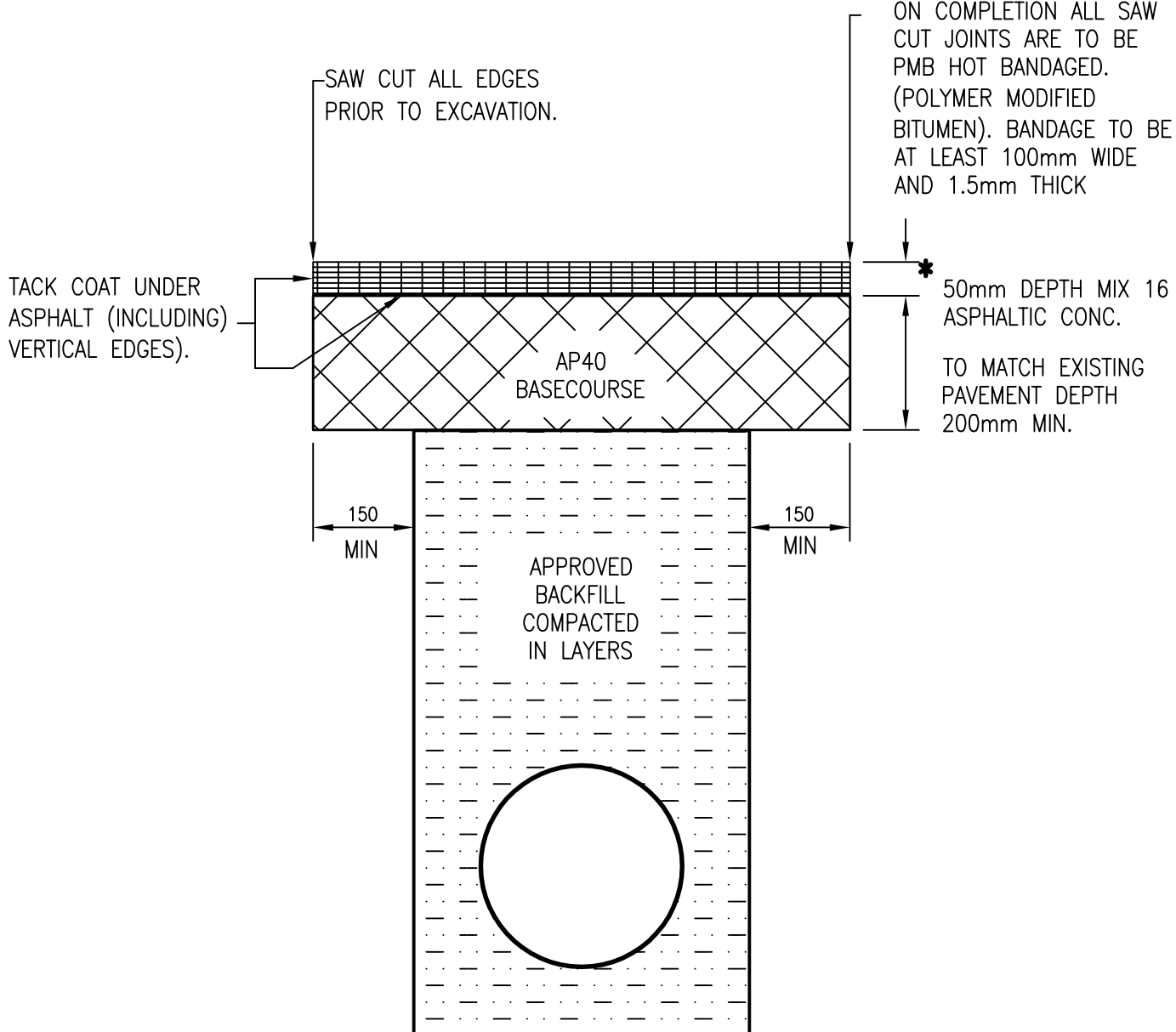

FOR CHIP SEAL, THIN ASPHALT & DEEP ASPHALT

1. UNSEALED ROADS & SHOULDERS. REINSTATEMENT TO BE 150MM DEPTH OF 40MM BASCOURSE TOPPED OFF WITH 50MM DEPTH OF 20MM BASCOURSE.
2. FOR FINISHED SEAL LEVEL TOLERANCES SEE X-6(B) (PG 92).
3. *DEPTH TO MATCH EXISTING BITUMINOUS LAYER DEPTH, WHERE DEPTH IS GREATER THAN 50MM.

| | | |
|---|--|---------------|
| NELSON CITY COUNCIL | TRENCH REINSTATEMENT IN CARRIAGEWAY | |
| | ASSET MANAGEMENT DIVISION | PLAN No. |
| APPROVED | Jan. 2003 | 21/700 |
| MANAGER INFRASTRUCTURAL ASSETS | DATE | SHEET 1 |

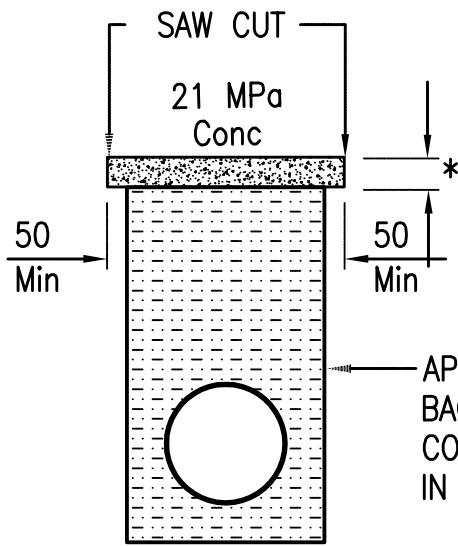

* 75mm FOR FOOTPATH. 100mm FOR RESIDENTIAL CROSSING WITH 665 MESH (or 150mm UNREINFORCED). 200mm FOR COMMERCIAL CROSSING WITH 665 MECH. FOR INDUSTRIAL CROSSING PAVEMENT TO SPECIFIC DESIGN (TO MATCH EXISTING).

CONCRETE

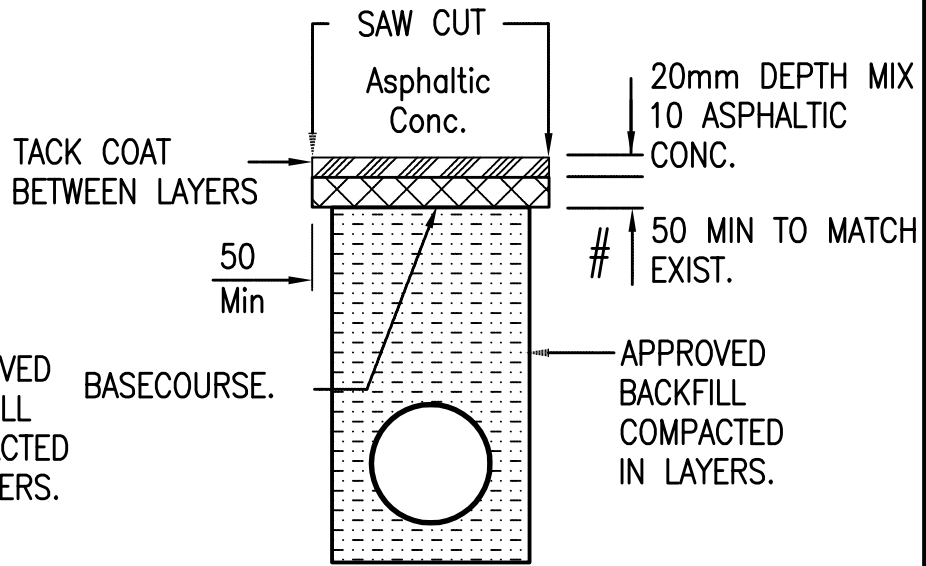

FOOTPATH PAVEMENT DEPTH MAY BE REQUIRED TO BE INCREASED WHERE BACKFILL MATERIAL IS OF LESSER QUALITY THAN SURROUNDING SUBGRADE MATERIAL.

THIN ASPHALTIC (FOR CHIP SEAL FOOTPATHS ALSO)

FOR VEHICLE CROSSINGS DETAILS REFER TO 21/304 SHEETS 1 AND 2

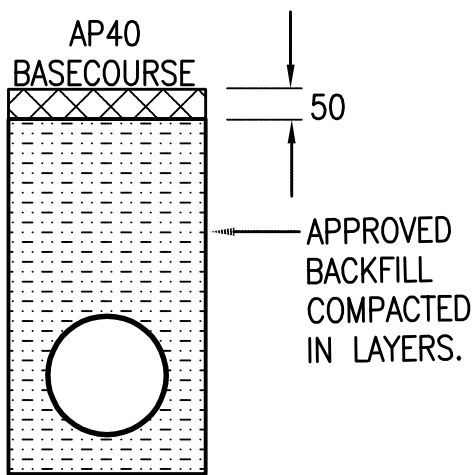

GRAVEL

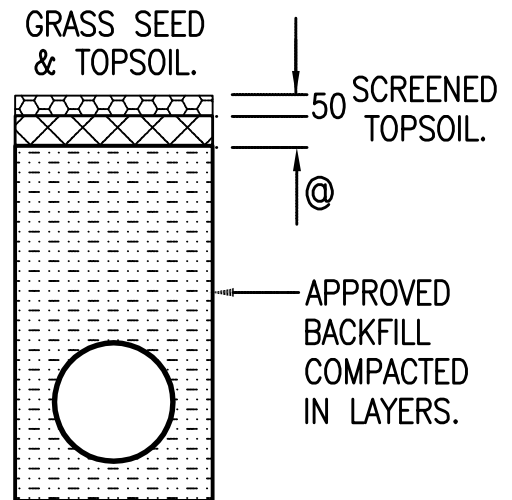

@ UNSCREENED TOPSOIL (50mm FOR CLAY FILLS, 100MM FOR GRAVEL OR SAND FILLS). **GRASS**

**NELSON
CITY
COUNCIL**

TRENCH REINSTATEMENT IN FOOTPATH

ASSET MANAGEMENT DIVISION

APPROVED

MANAGER INFRASTRUCTURAL ASSETS

Jan. 2003

DATE

PLAN No.

21/700

SHEET 2

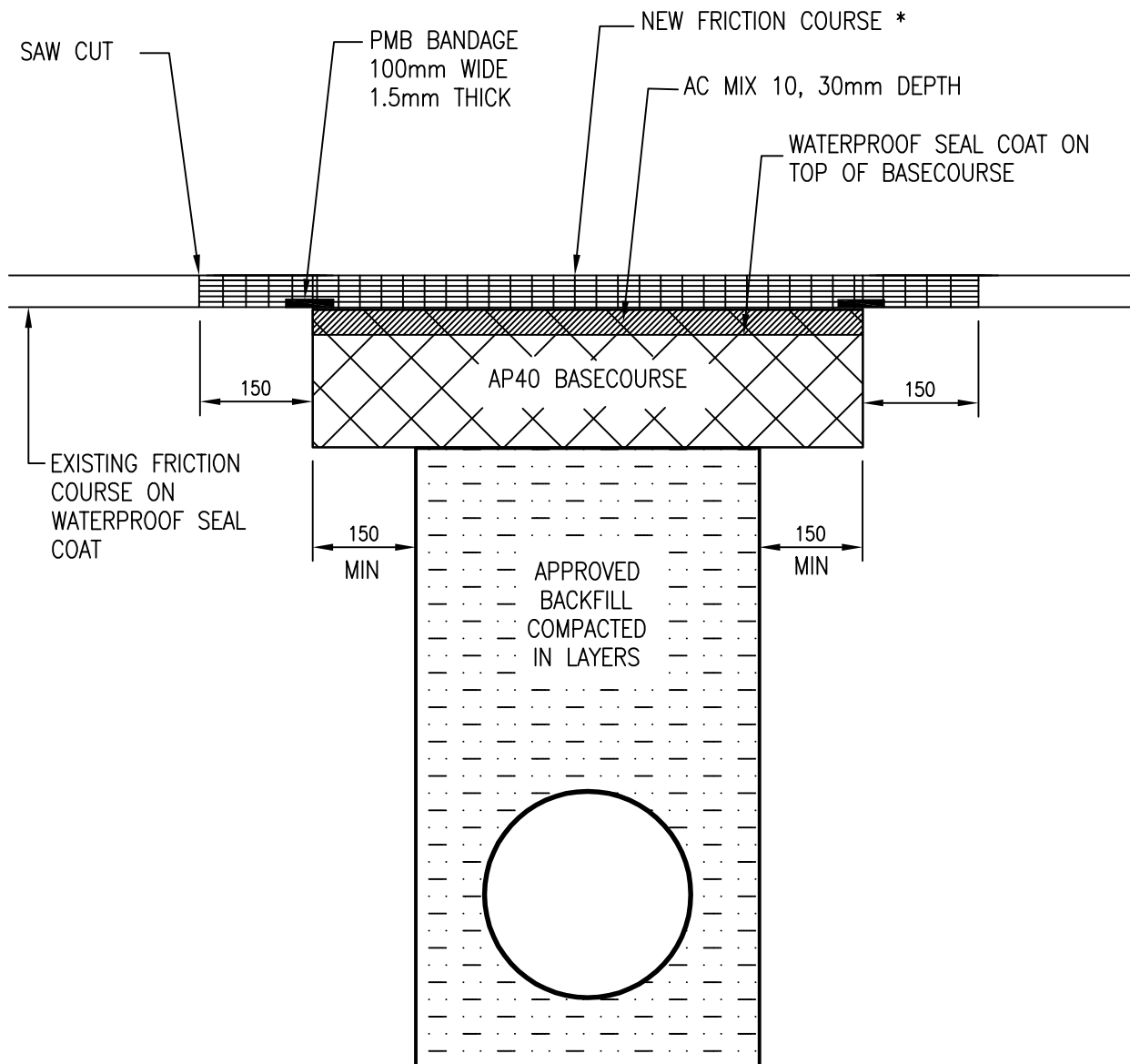

FOR FRICTION COURSE

1. FOR FINISHED SEAL LEVEL TOLERANCES SEE X-6(B) (PG 92).
2. *DEPTH TO MATCH EXISTING BITUMINOUS LAYER DEPTH, WHERE DEPTH IS GREATER THAN 50MM.

**NELSON
CITY
COUNCIL**

TRENCH REINSTATEMENT IN CARRIAGEWAY (FRICTION COURSE)

ASSET MANAGEMENT DIVISION

APPROVED

MANAGER INFRASTRUCTURAL ASSETS

Jan. 2003

DATE

PLAN No.

21/700

SHEET 3

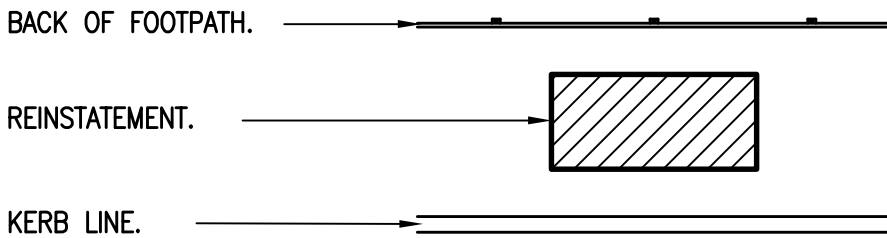

NOT APPROVED

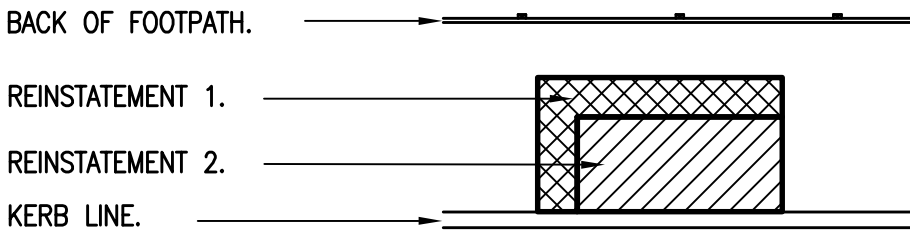

NOT APPROVED

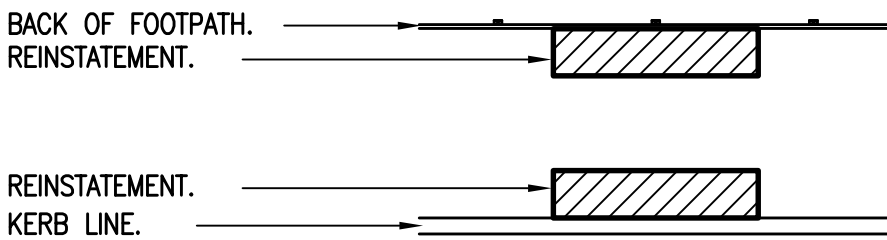

NOT APPROVED

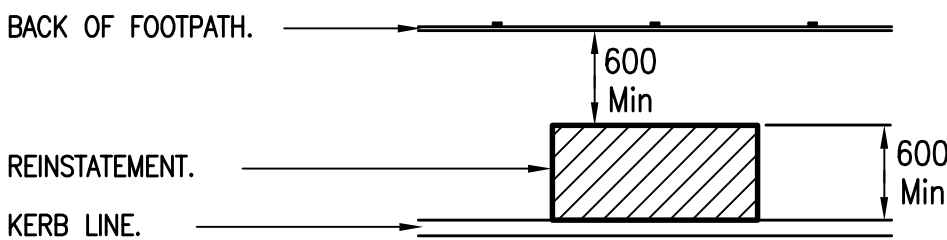

APPROVED
(Excluding Arterial & Principal roads & CBD areas)

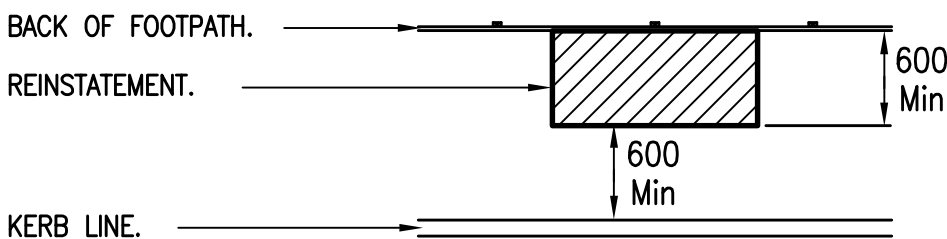

APPROVED
(Excluding Arterial & Principal roads & CBD areas)

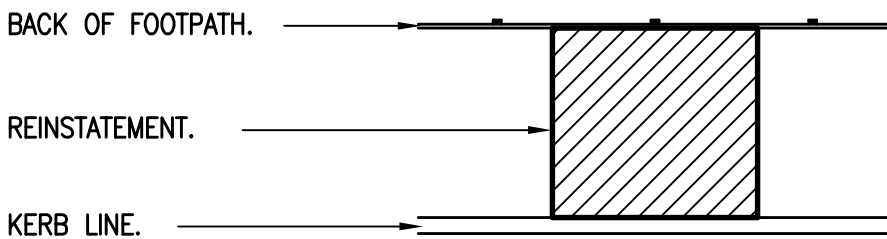

APPROVED

NELSON CITY COUNCIL

FOOTPATH SURFACE REINSTATEMENT

ASSET MANAGEMENT DIVISION

APPROVED

MANAGER INFRASTRUCTURAL ASSETS

Jan. 2003

DATE

PLAN No.

21/701

SHEET 1

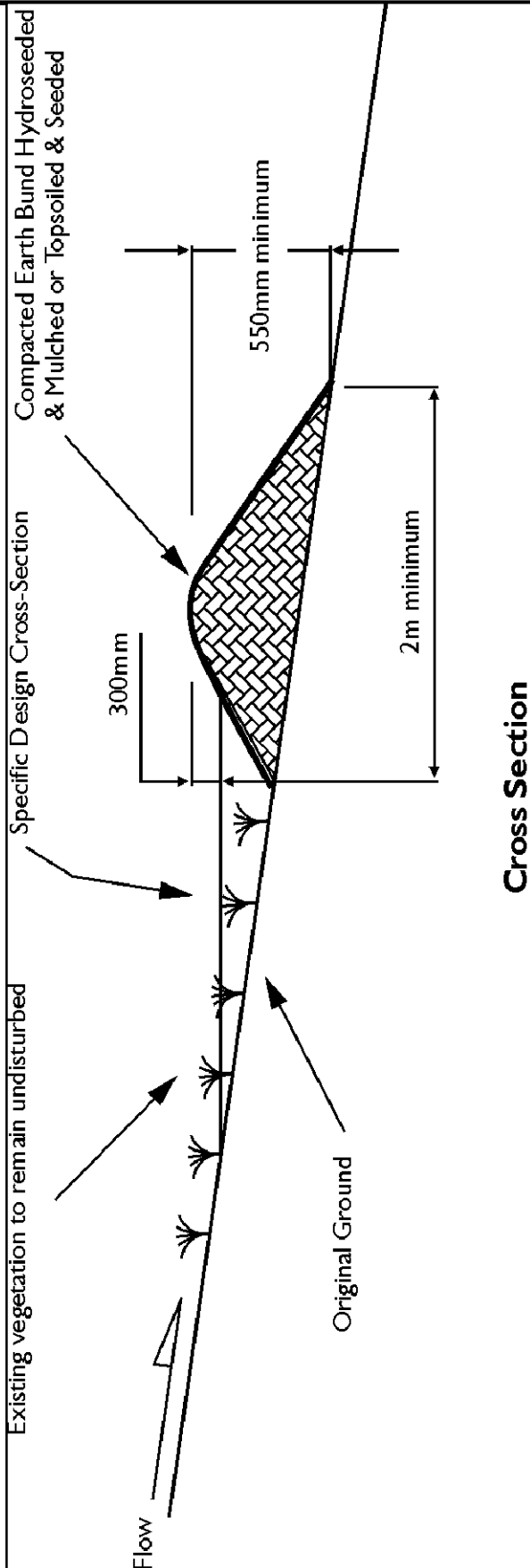

**NELSON
CITY
COUNCIL**

**CLEARWATER RUNOFF
DIVERSION BUND**

ASSET MANAGEMENT DIVISION

APPROVED

MANAGER INFRASTRUCTURAL ASSETS

Feb. 2006

DATE

PLAN No.

21/800

SHEET 1

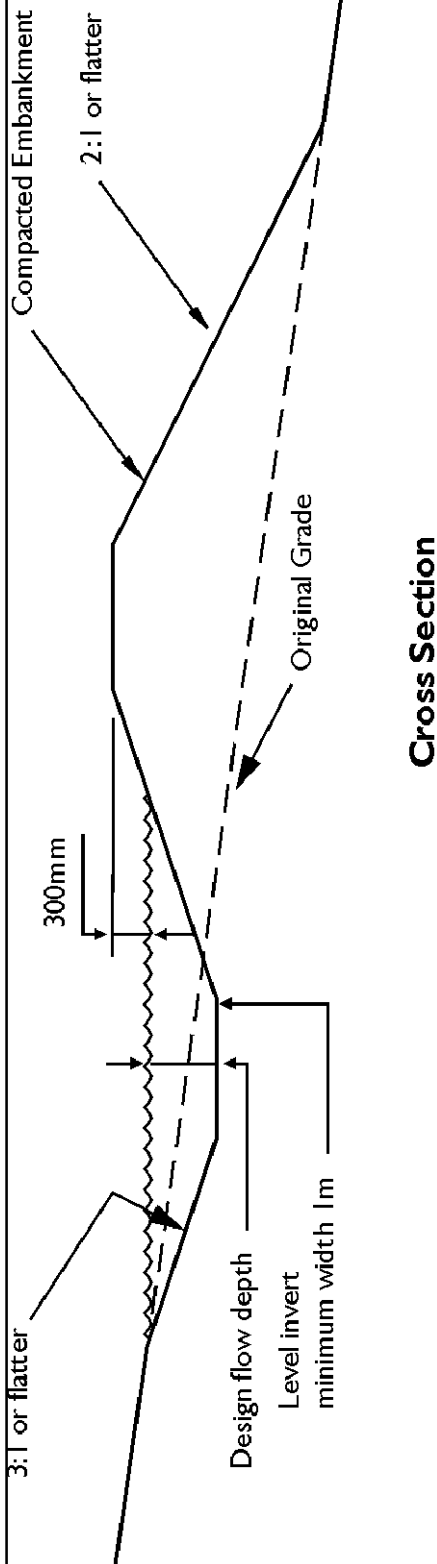

Cross Section

**NELSON
CITY
COUNCIL**

**RUNOFF DIVERSION
CHANNEL**

ASSET MANAGEMENT DIVISION

APPROVED

MANAGER INFRASTRUCTURAL ASSETS

Feb. 2006

DATE

PLAN No.

21/800

SHEET 2

Compacted Earth Bund

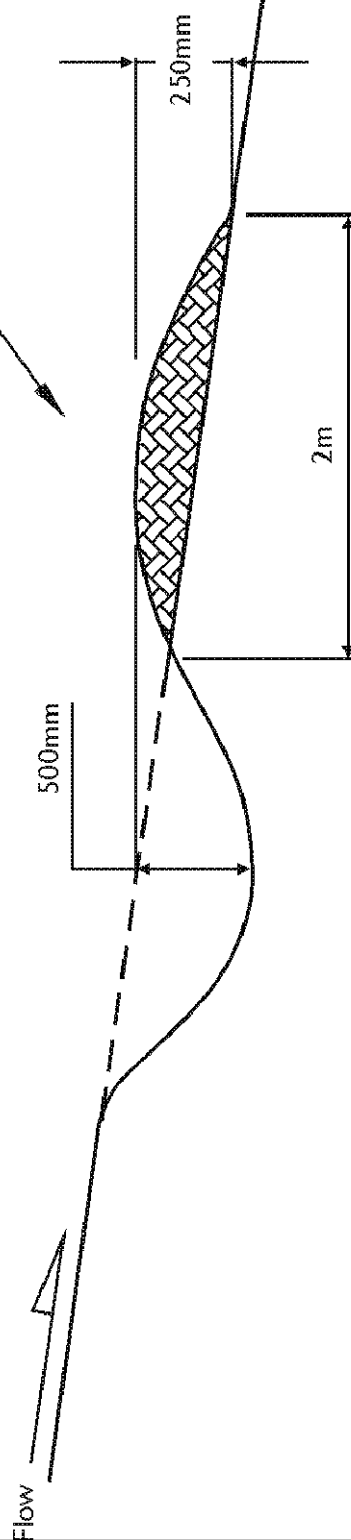

Cross Section

**NELSON
CITY
COUNCIL**

CONTOUR DRAIN

ASSET MANAGEMENT DIVISION

APPROVED

MANAGER INFRASTRUCTURAL ASSETS

Feb. 2006

DATE

PLAN No.

21/801

SHEET 1

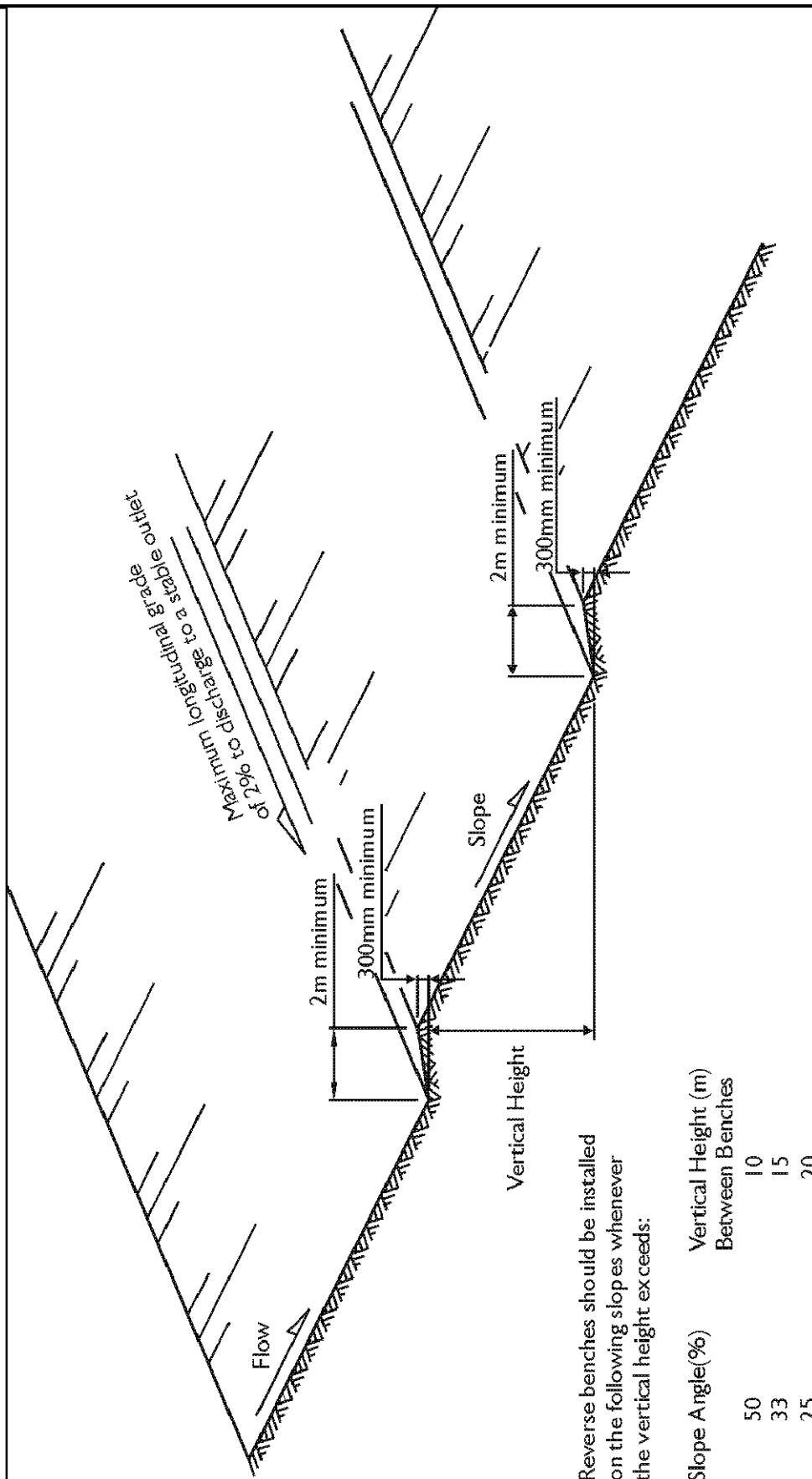

**NELSON
CITY
COUNCIL**

BENCHED SLOPE

ASSET MANAGEMENT DIVISION

APPROVED 

 MANAGER INFRASTRUCTURAL ASSETS

Feb. 2006
 DATE

PLAN No.

21/801

SHEET 2

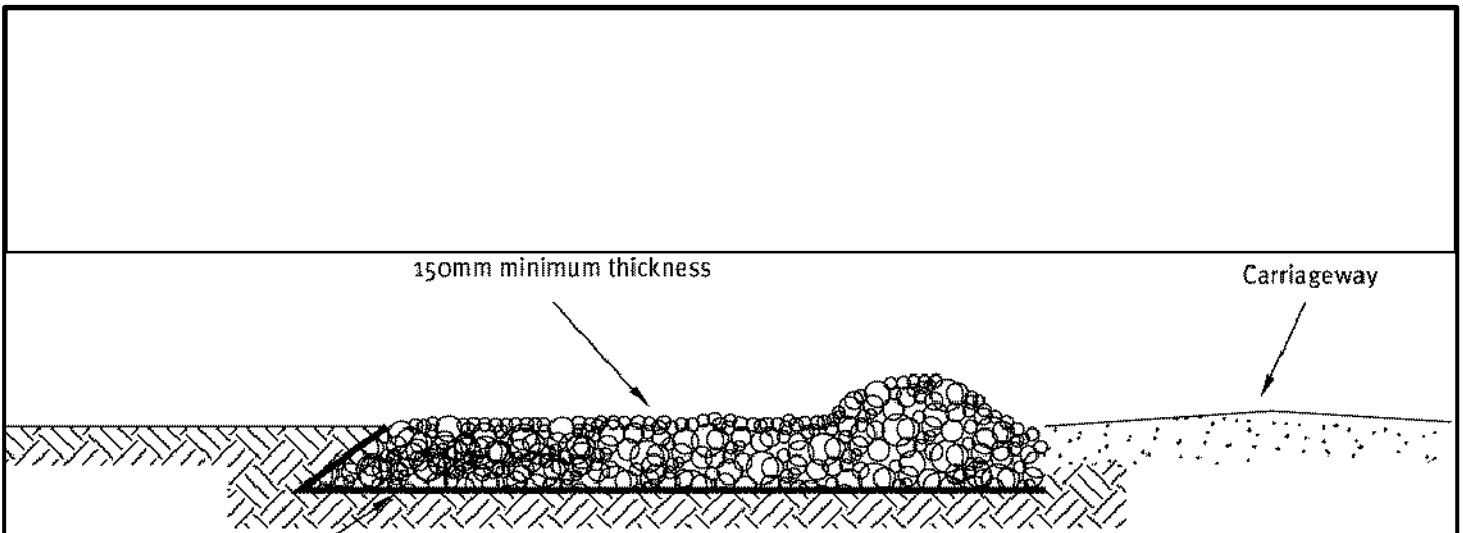

Side Elevation

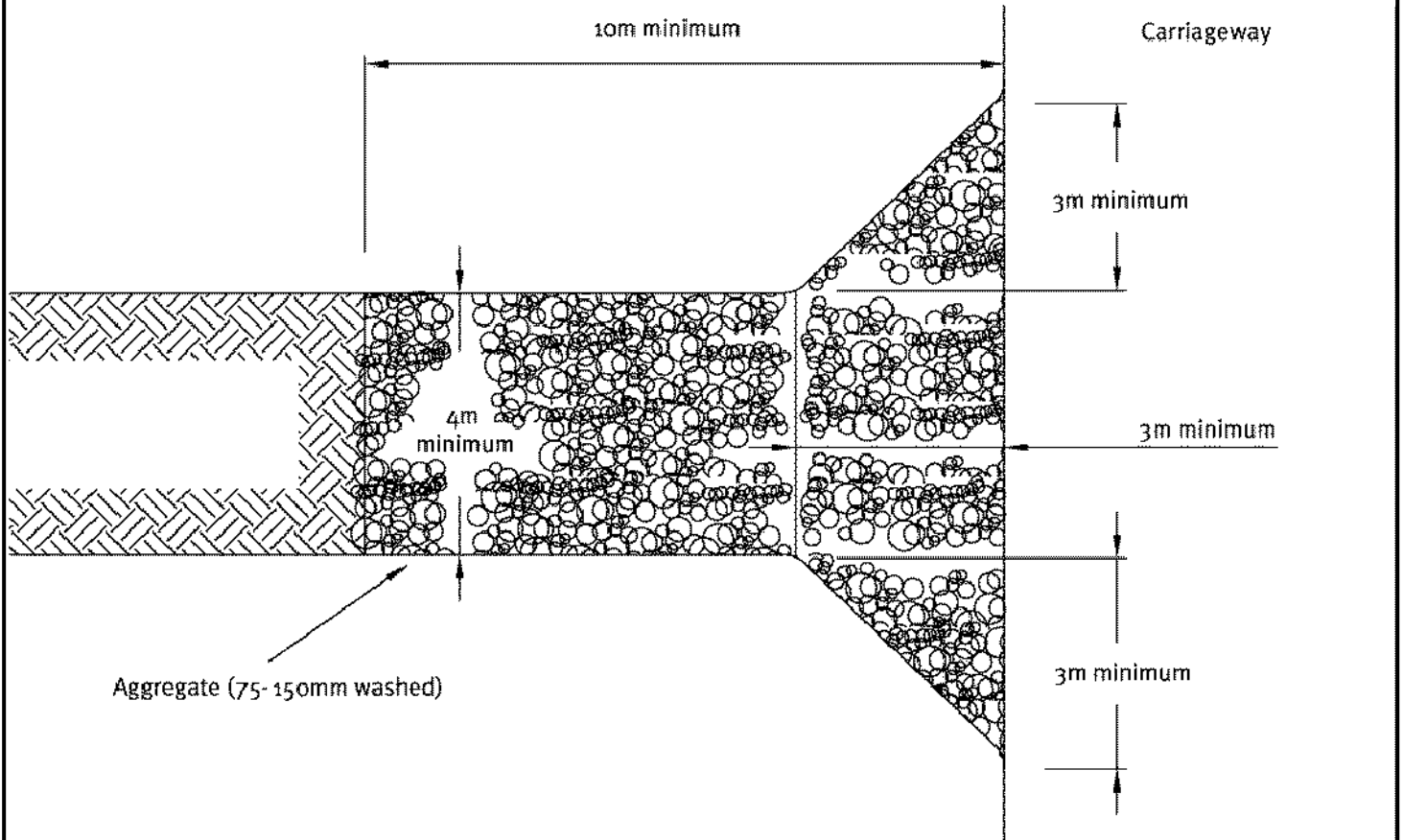

Plan View

**NELSON
CITY
COUNCIL**

**STABILISED CONSTRUCTION
ENTRANCE**

ASSET MANAGEMENT DIVISION

APPROVED

MANAGER INFRASTRUCTURAL ASSETS

Feb. 2006

DATE

PLAN No.

21/802

SHEET 1

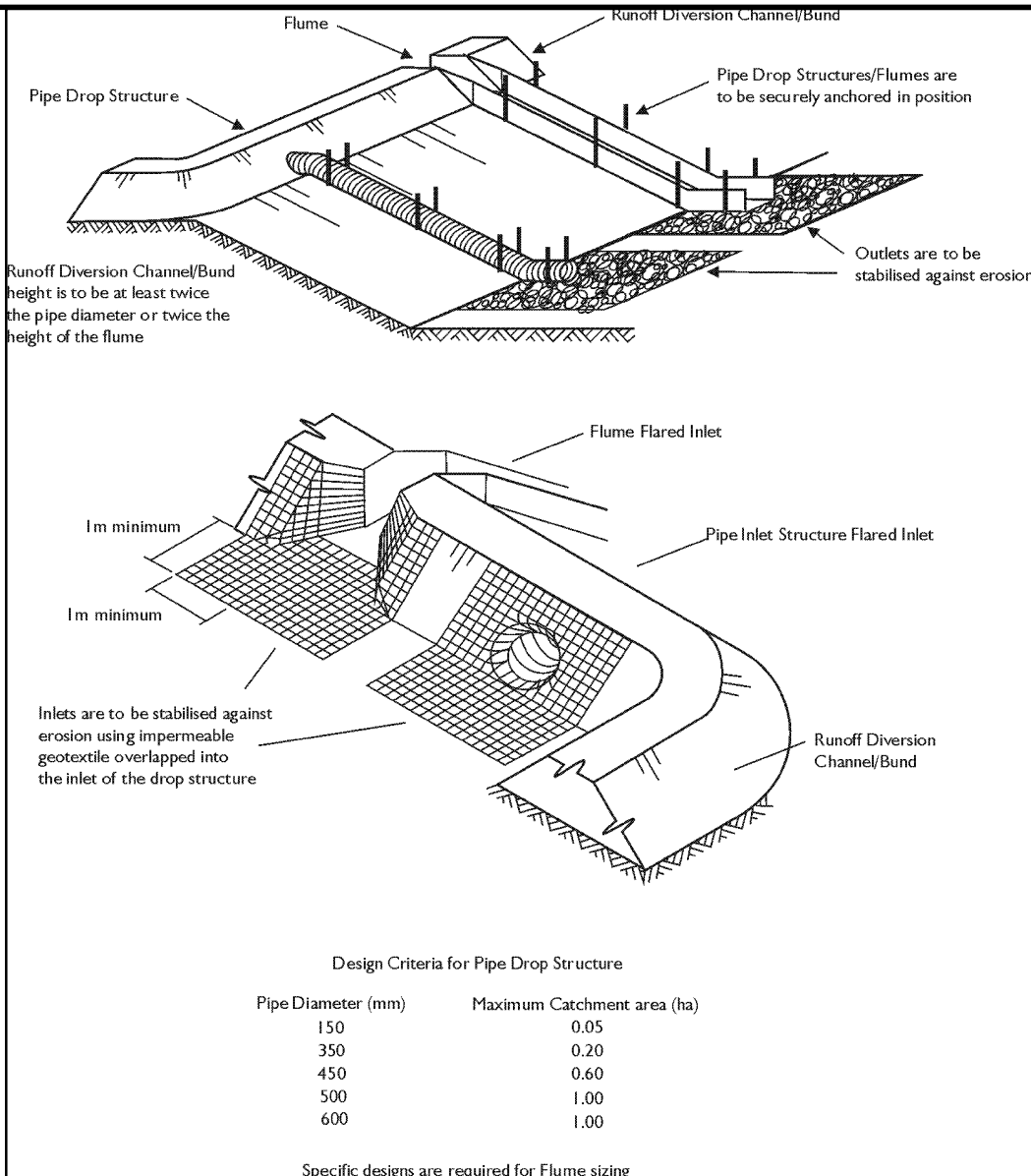

Design Criteria for Pipe Drop Structure

| Pipe Diameter (mm) | Maximum Catchment area (ha) |
|--------------------|-----------------------------|
| 150 | 0.05 |
| 350 | 0.20 |
| 450 | 0.60 |
| 500 | 1.00 |
| 600 | 1.00 |

Specific designs are required for Flume sizing

Flume detail

For catchments up to 1ha

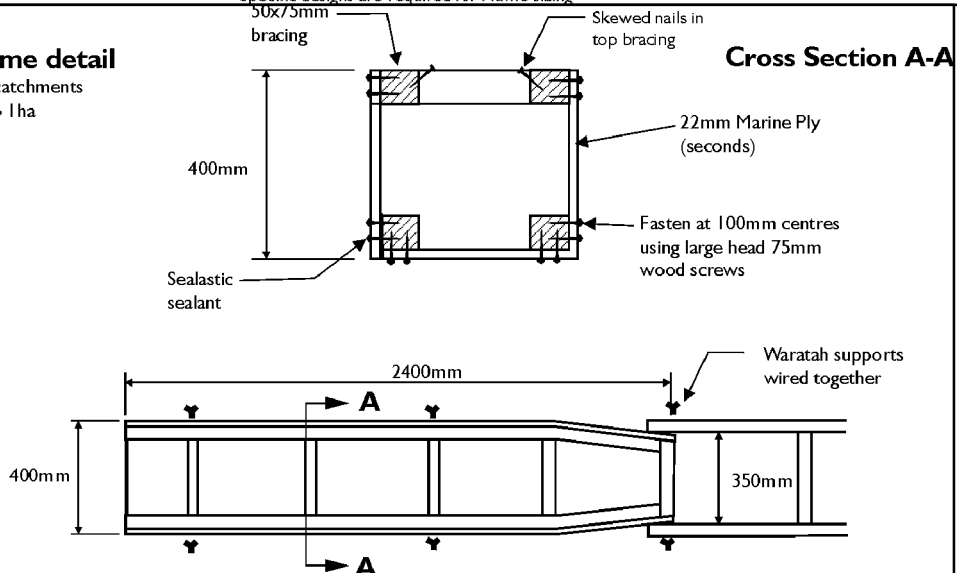

**NELSON
CITY
COUNCIL**

PIPE DROP STRUCTURE

ASSET MANAGEMENT DIVISION

APPROVED

MANAGER INFRASTRUCTURAL ASSETS

Feb. 2006

DATE

PLAN No.

21/803

SHEET 1

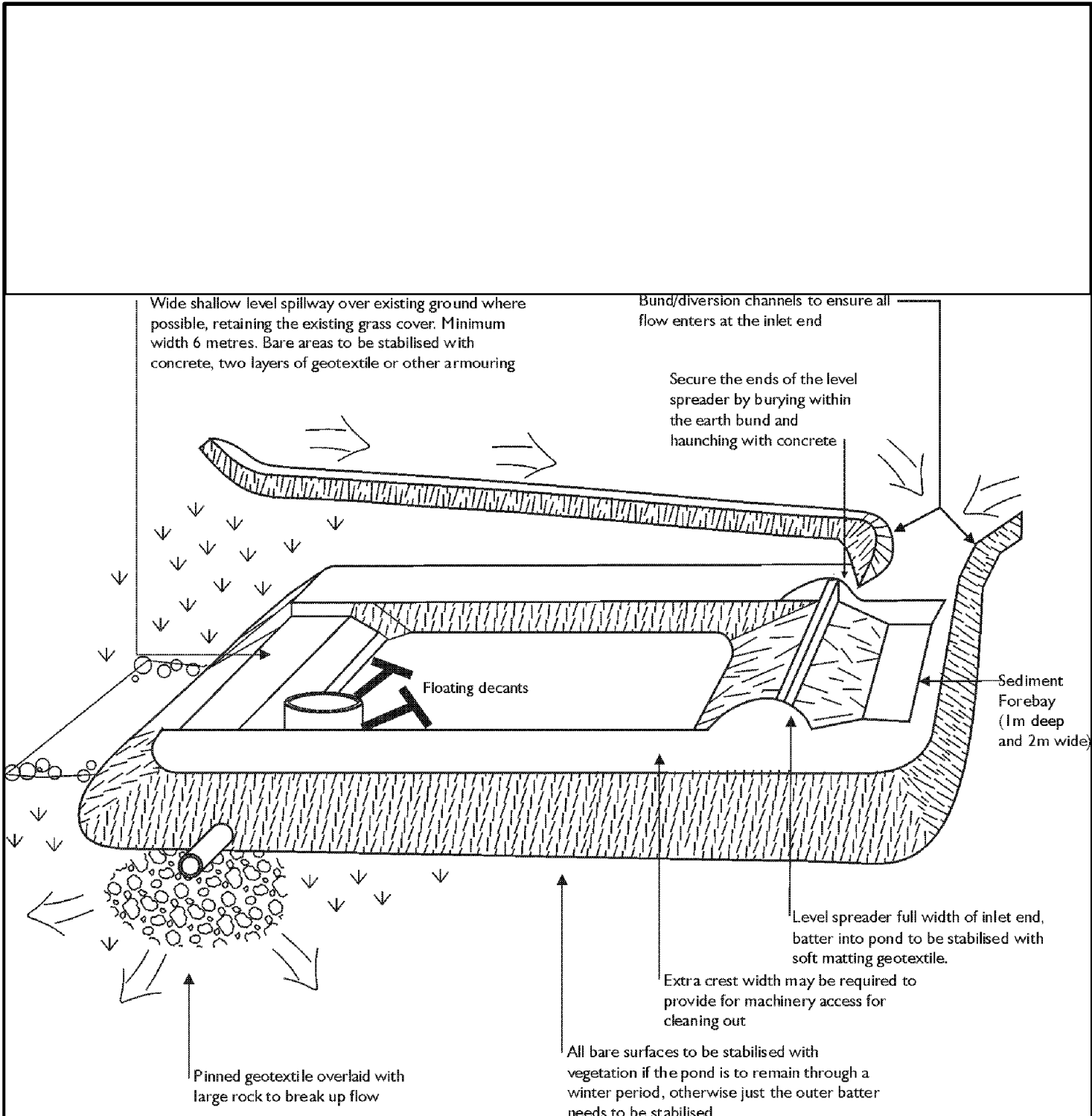

**NELSON
CITY
COUNCIL**

SEDIMENT RETENTION POND

ASSET MANAGEMENT DIVISION

PLAN No.

APPROVED

Feb. 2006

21/804

MANAGER INFRASTRUCTURAL ASSETS

DATE

SHEET 1

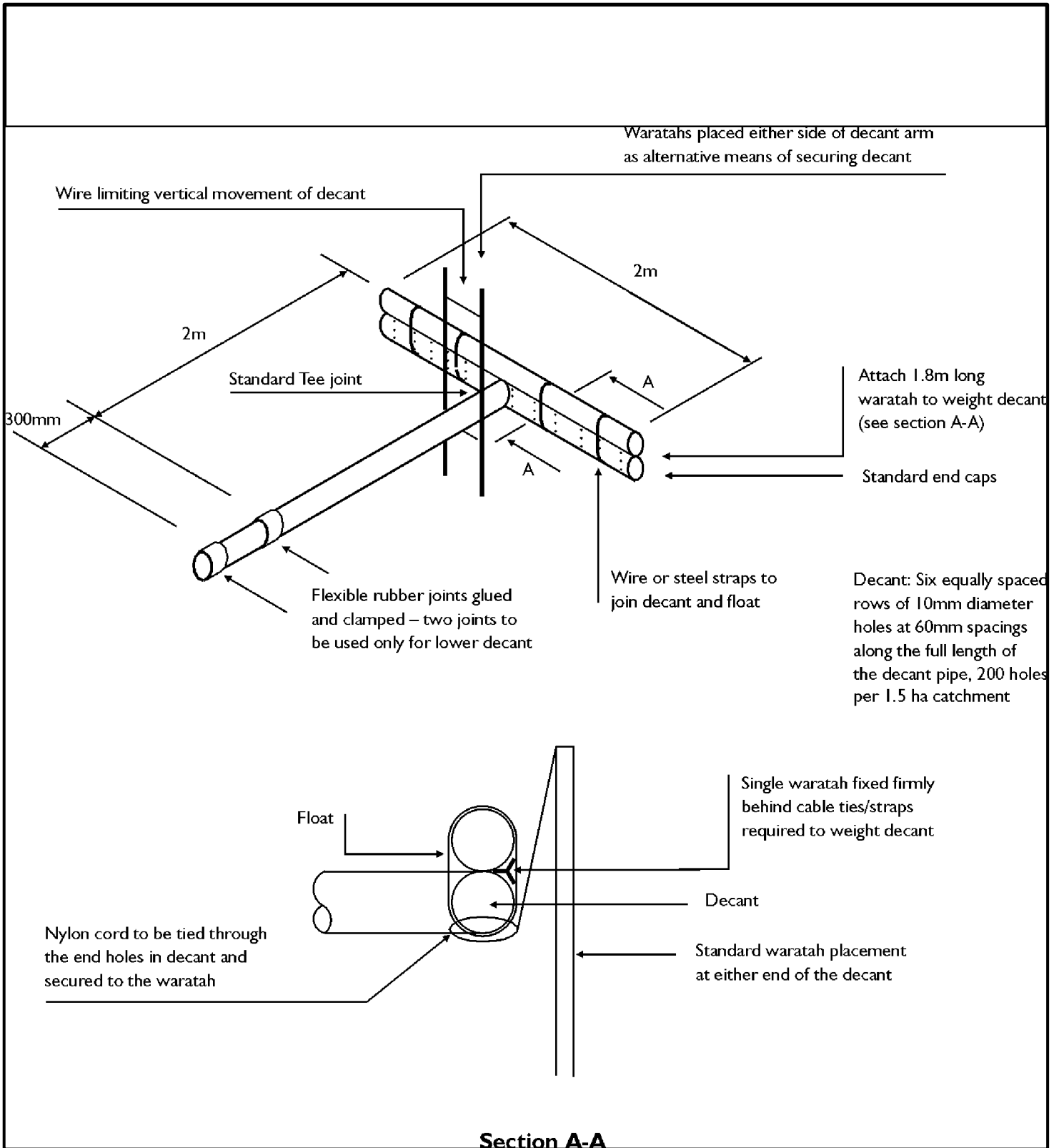

**NELSON
CITY
COUNCIL**

DECANT DETAIL

ASSET MANAGEMENT DIVISION

APPROVED *[Signature]* Feb. 2006

MANAGER INFRASTRUCTURAL ASSETS DATE

PLAN No.

21/804

SHEET 2

Level spreader
150 mm x 50 mm
timber weir

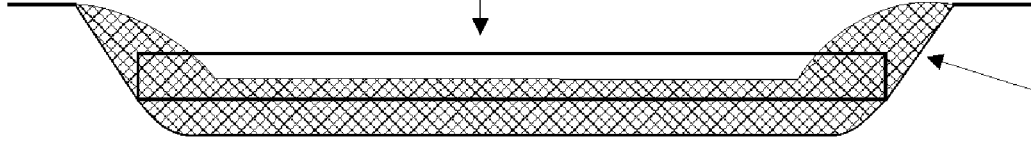

Earth Bund with
site concrete
cover

Level spreader full width of inlet end,
stabilised from the beginning of the inlet
to the pond invert with appropriate soft
matting textile.

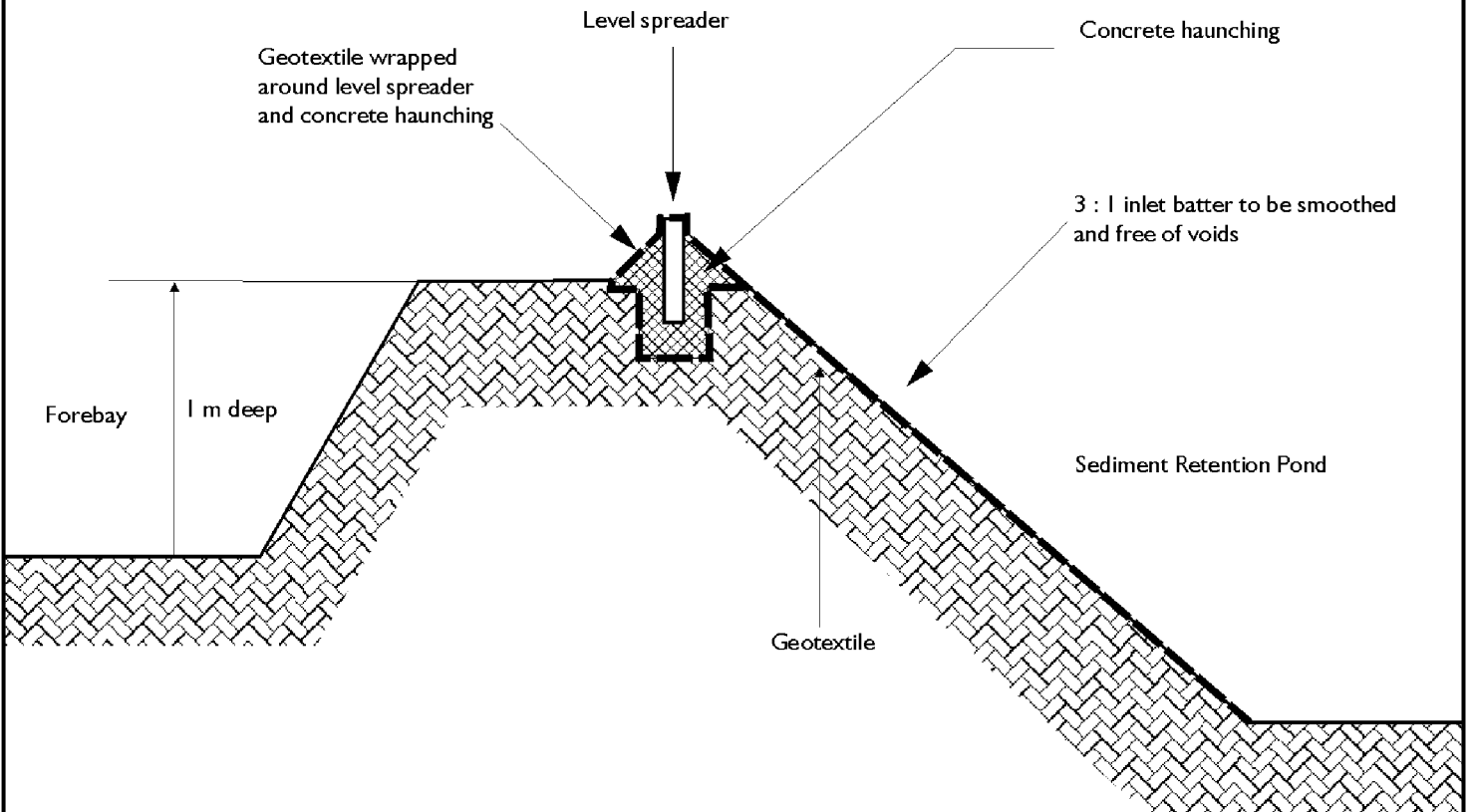

Forebay
1 m deep

Concrete haunching

3 : 1 inlet batter to be smoothed
and free of voids

Sediment Retention Pond

Geotextile

**NELSON
CITY
COUNCIL**

LEVEL SPREADER

ASSET MANAGEMENT DIVISION

APPROVED

MANAGER INFRASTRUCTURAL ASSETS

Feb. 2006

DATE

PLAN No.

21/804

SHEET 3

Width of top embankment should be wide enough to ensure machinery access for de-sludging of pond, if there are no other access points available.

Spillway compacted and smoothed to eliminate all voids prior to laying and pinning appropriate geotextile/concrete.

Pond batters 2:1 to 3:1

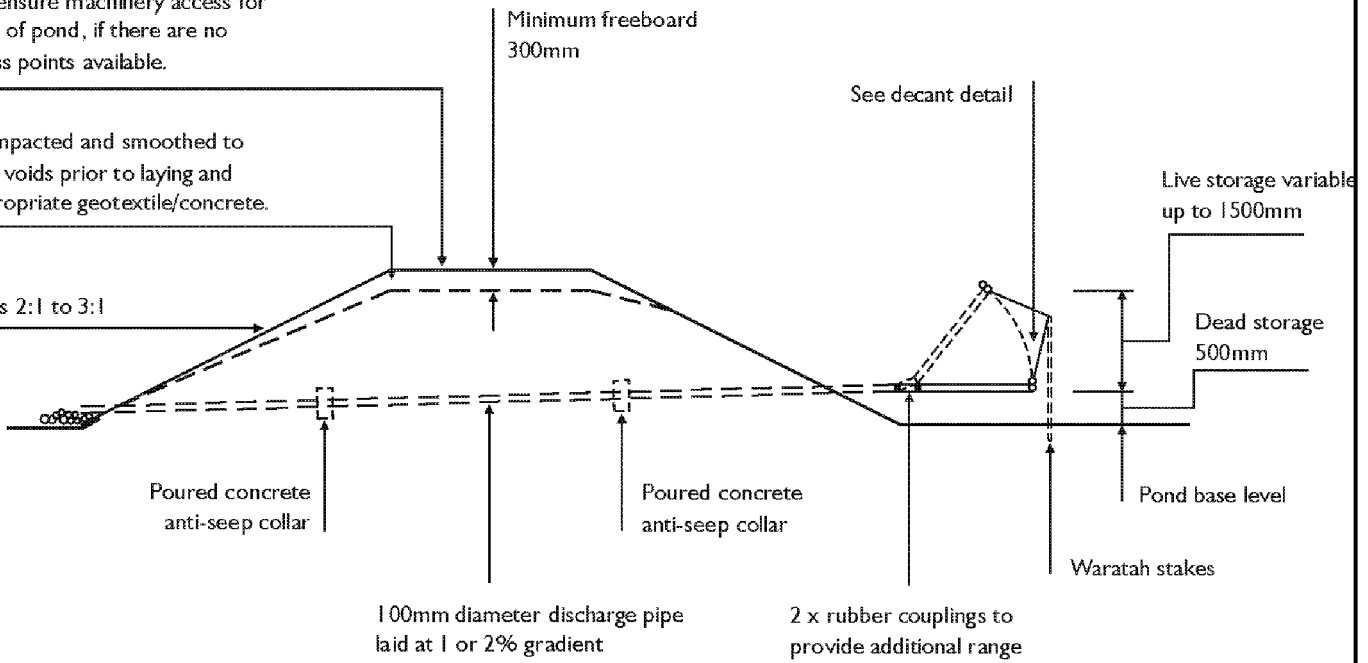

Cross Section

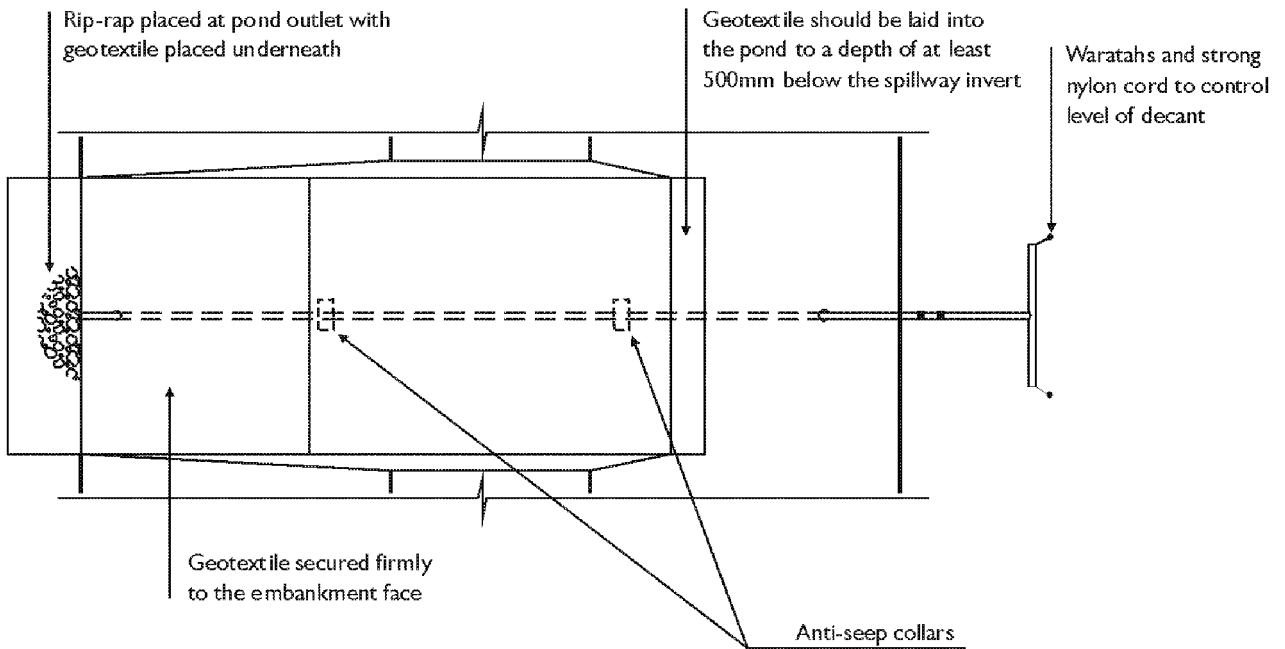

Plan

**NELSON
CITY
COUNCIL**

**SEDIMENT RETENTION POND FOR
CATCHMENTS UP TO 1.5ha**

ASSET MANAGEMENT DIVISION

APPROVED

MANAGER INFRASTRUCTURAL ASSETS

Feb. 2006

DATE

PLAN No.

21/804

SHEET 4

Width of top embankment should be wide enough to ensure machinery access for de-sludging of pond, if there are no other access points available.

Spillway compacted and smoothed to eliminate all voids prior to laying and pinning appropriate geotextile/concrete.

Pond batters 2:1 to 3:1

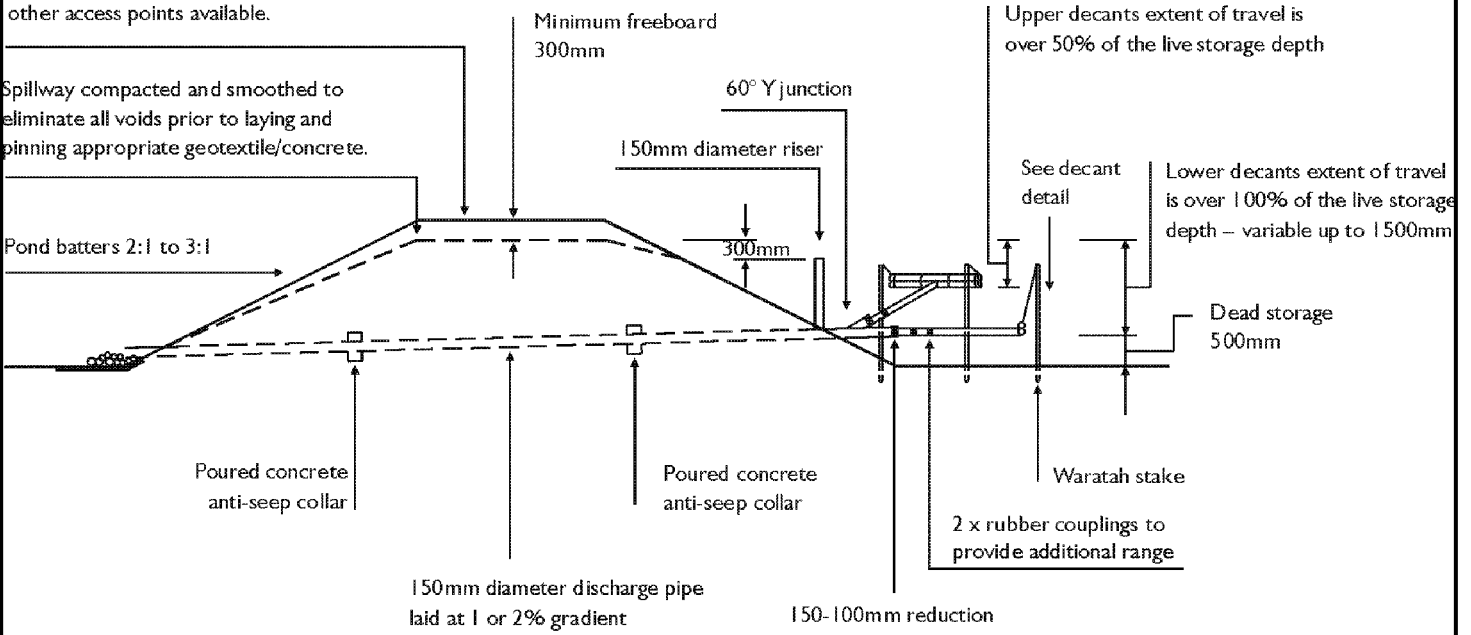

Cross Section

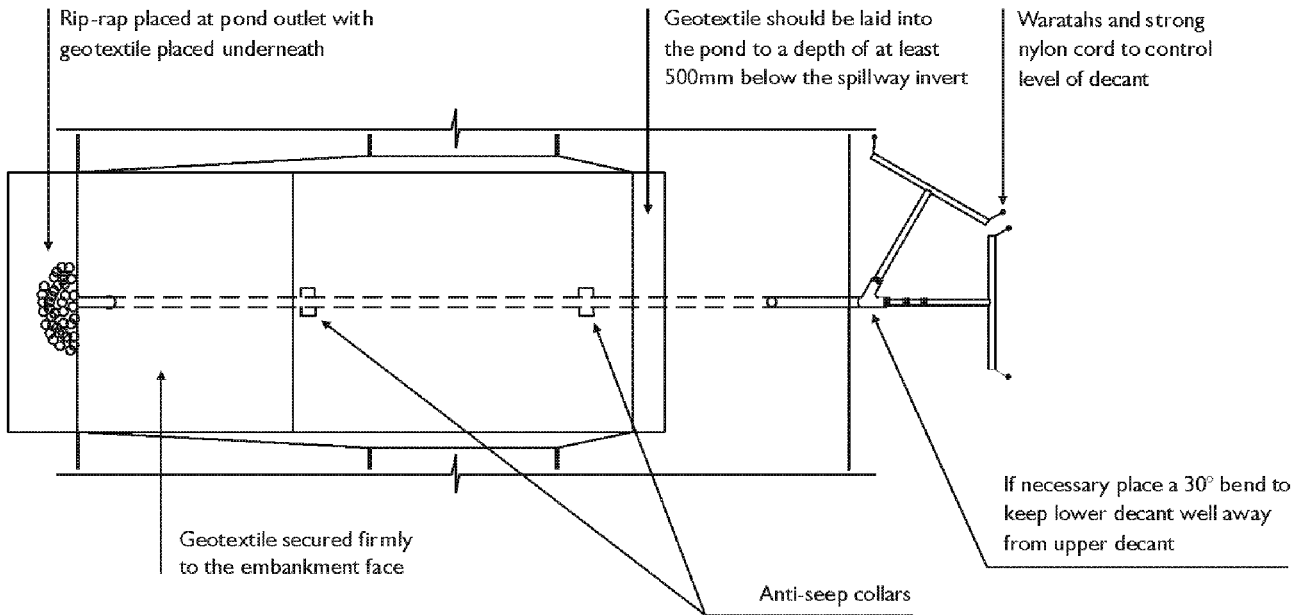

Plan

**NELSON
CITY
COUNCIL**

**SEDIMENT RETENTION POND FOR
CATCHMENTS BETWEEN 1.5ha and 3ha**

ASSET MANAGEMENT DIVISION

APPROVED

MANAGER INFRASTRUCTURAL ASSETS

Feb. 2006

DATE

PLAN No.

21/804

SHEET 5

Width of top embankment should be wide enough to ensure machinery access for de-sludging of pond, if there are no other access points available.

Spillway compacted and smoothed to eliminate all voids prior to laying and pinning appropriate geotextile/concrete.

Pond batters 2:1 to 3:1

Poured concrete anti-seep collar

300mm diameter discharge pipe laid at 1 or 2% gradient

Poured concrete anti-seep collar

Concrete riser may require weighting or anchoring to prevent floating

300mm

Lowest Inlet pipe to riser is angled upward at 15° to ease tension on flexible joint

Upper decant operates over top 1/3 of live storage only

Middle decant operates over top 2/3 of live storage only

Lower decant operates over full depth of live storage up to 1500mm

500mm dead storage

Waratah stakes required for all decants

See decant detail

Cross Section

Rip-rap placed at pond outlet with geotextile placed underneath

Geotextile should be laid into the pond to a depth of at least 500mm below the spillway invert

Waratahs and strong nylon cord to control level of decant

Geotextile secured firmly to the embankment face

Anti-seep collars

Plan

NELSON CITY COUNCIL

SEDIMENT RETENTION POND FOR CATCHMENTS BETWEEN 3ha and 5ha

ASSET MANAGEMENT DIVISION

APPROVED



MANAGER INFRASTRUCTURAL ASSETS

Feb. 2006

DATE

PLAN No.

21/804

SHEET 6

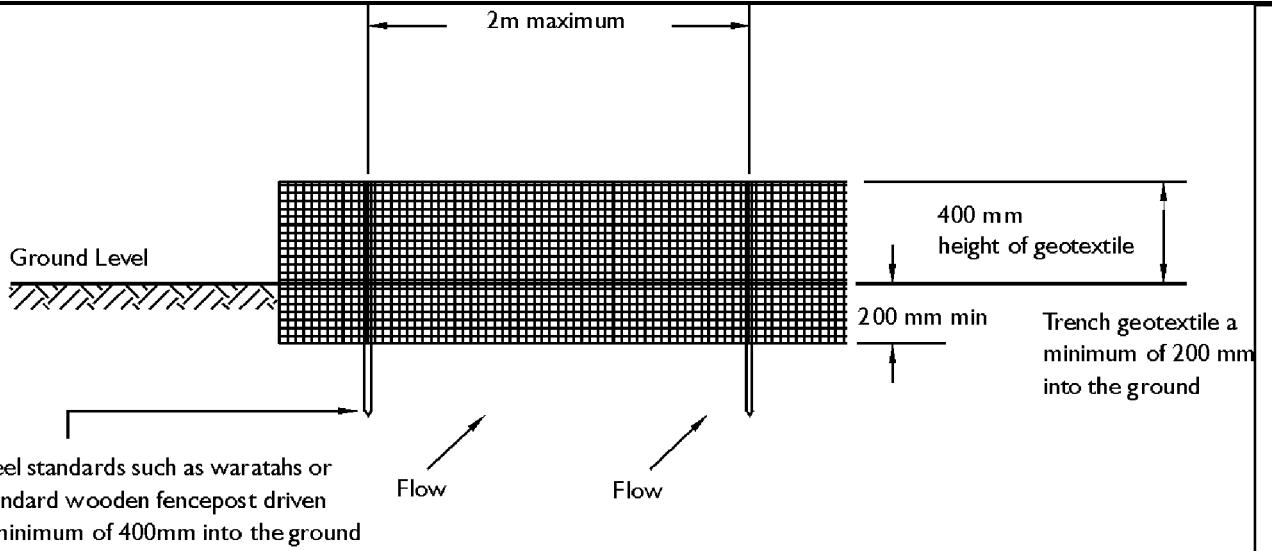

Elevation

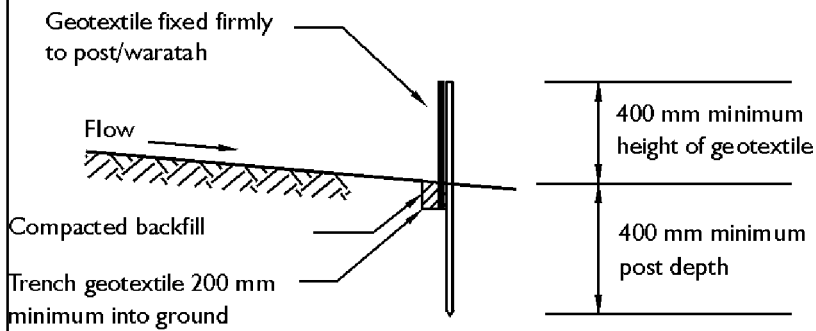

Cross Section

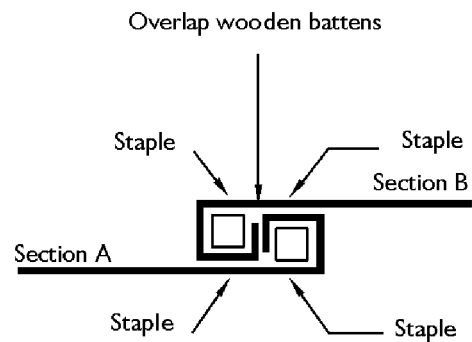

Standard Fabric Joint

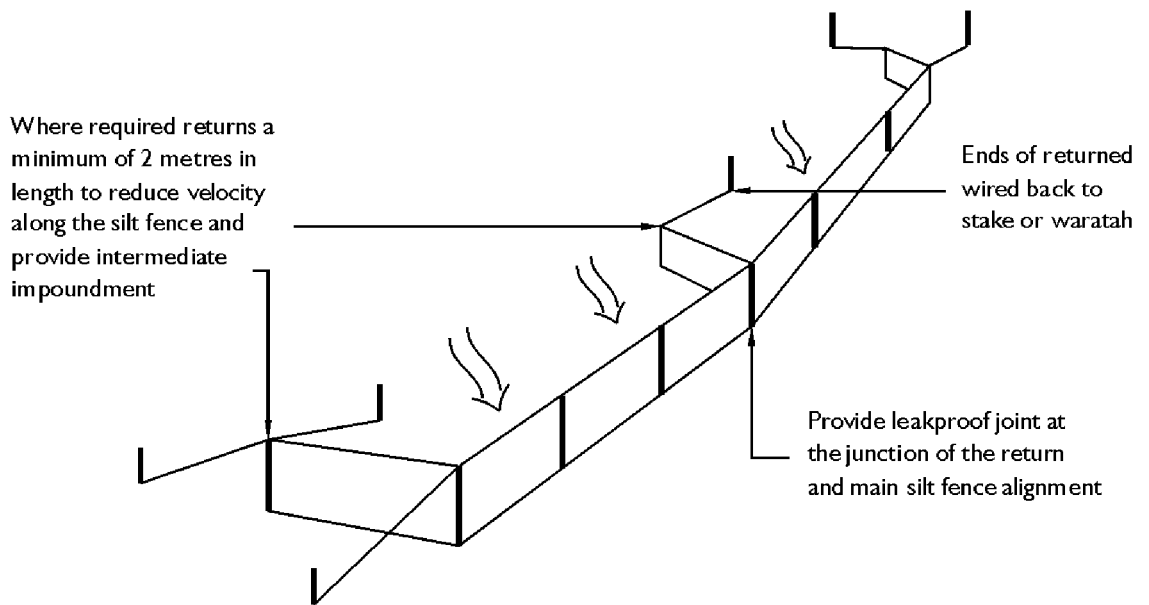

Perspective View

**NELSON
CITY
COUNCIL**

SILT FENCE

ASSET MANAGEMENT DIVISION

APPROVED

MANAGER INFRASTRUCTURAL ASSETS

Feb. 2006

DATE

PLAN No.

21/805

SHEET 1

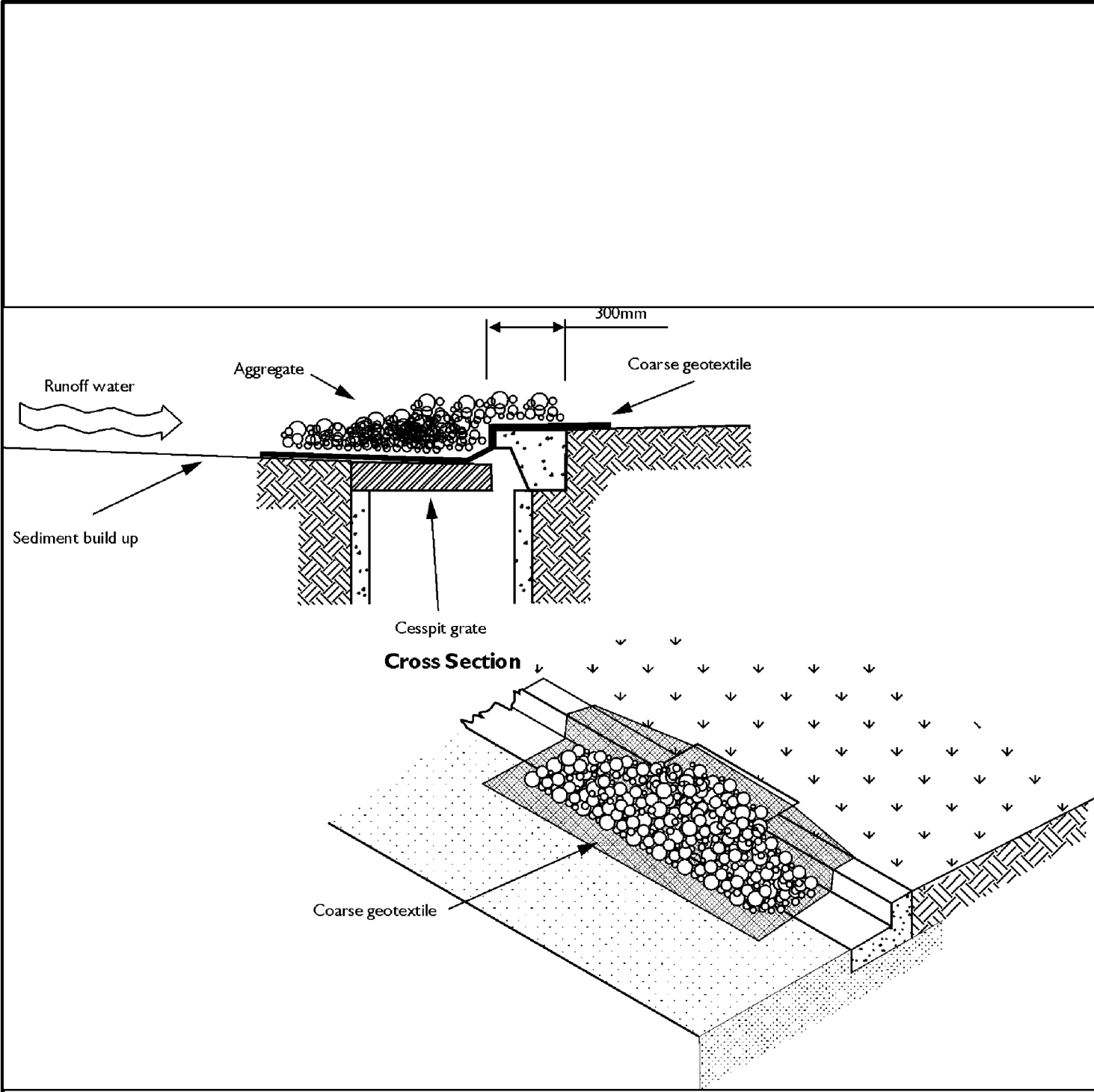

**NELSON
CITY
COUNCIL**

STORMWATER INLET PROTECTION

ASSET MANAGEMENT DIVISION

APPROVED

MANAGER INFRASTRUCTURAL ASSETS

Feb. 2006

DATE

PLAN No.

21/806

SHEET 1

Cross Section

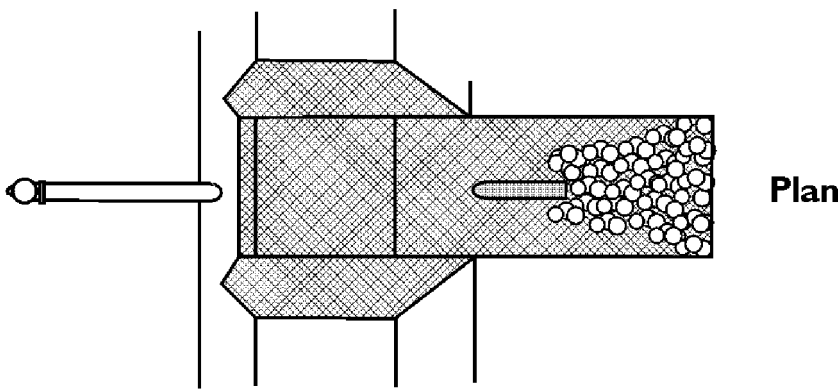
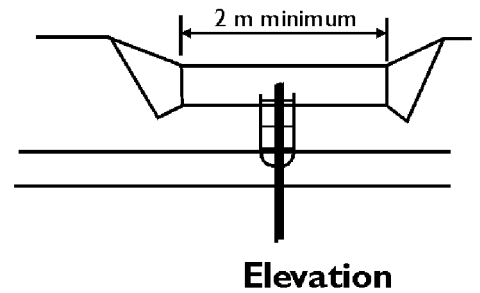
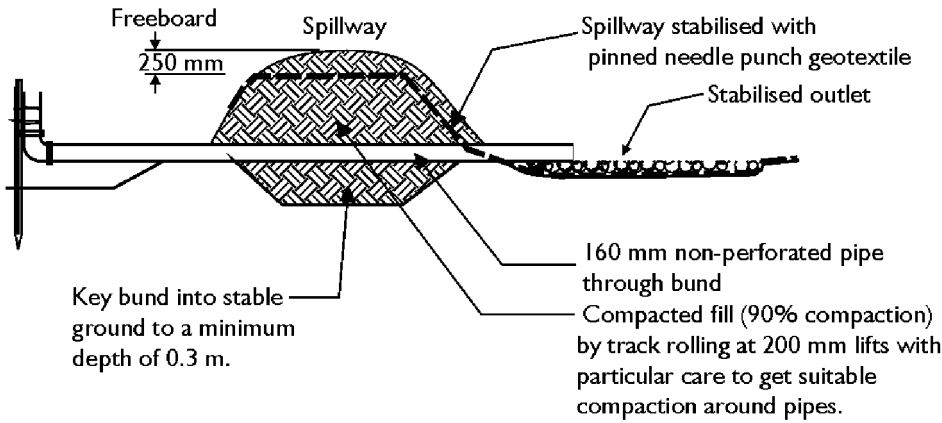

Decanting Earth Bund
 Maximum Catchment 0.3 ha
 2% volume
 (60m³ per 0.3 ha catchment)

Outlet Detail

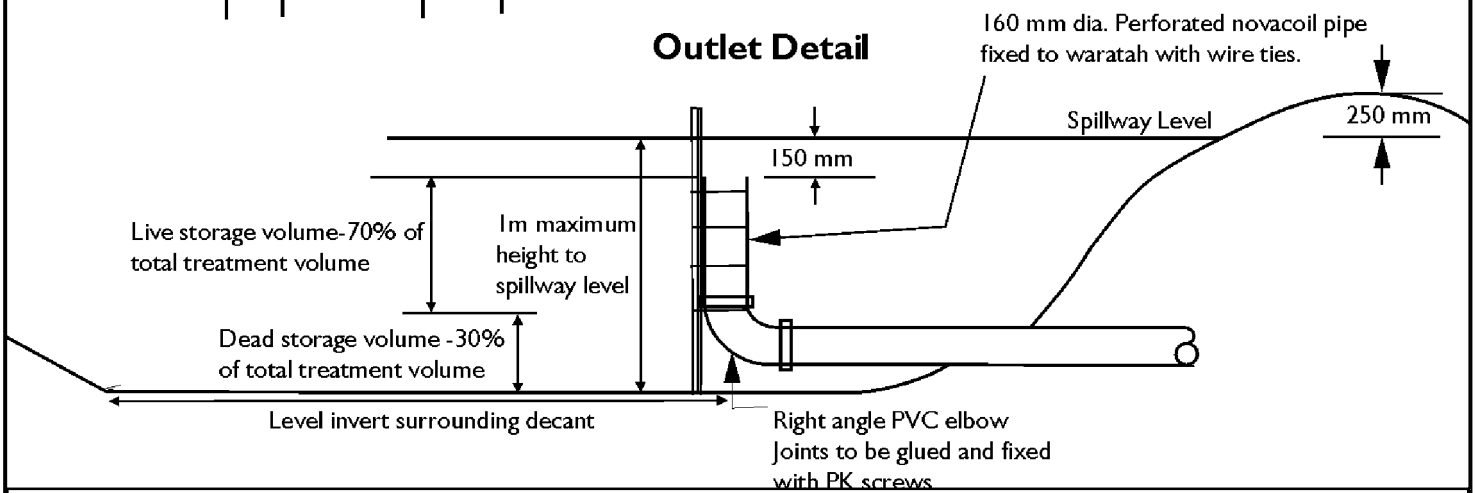

**NELSON
 CITY
 COUNCIL**

EARTH BUND

ASSET MANAGEMENT DIVISION

APPROVED

MANAGER INFRASTRUCTURAL ASSETS

Feb. 2006

DATE

PLAN No.

21/807

SHEET 1