

appendix 20

signs and

outdoor

advertising

AP20 overview

AP20.i This appendix deals with requirements for all signage and outdoor advertising.

AP20.1 definitions



Aerial display

means any display of advertising material on or attached to a balloon, blimp or similar device that is tethered to the ground but otherwise free to move, and includes searchlights and laser light displays.

Freestanding sign

means a sign which is freestanding, self supporting and not attached to, on or within any other building or structure but excludes small portable footpath signs, including sandwich board signs. For the purpose of this definition 'self supporting' means the sign shall not be braced by guy wires or the like.

Moving display

means a display in which any parts of the sign or its message involves movement or apparent movement aimed at drawing attention to the sign.

Skysign

means a sign erected

- a) above the parapet line of a building, or
- b) above the eave line of a building, or
- c) on any part of the roof of a building, or
- d) on any part of the roof of a verandah or on the fascia of a verandah which extends above the parapet line or eave line of the verandah.

Sign

means anything visible from a public place and having the purpose of disseminating a message, providing directions or attracting the attention of passers-by to a site, building, forthcoming event, or available goods and services. It includes the disseminating device, frame, advertising background, support structure, anchorage and associated illumination of any sign. The sign may be manufactured, painted, written, drawn, projected or disseminated, inflated or carved, in an aerial display, free-standing, or projecting from or attached to a building or other structure or object. A sign may include advertising by sound so as to be discernible from a public place.

This definition of sign excludes:

- a) road marking and traffic control and enforcement signs erected on roads by or on behalf of road controlling authorities including signs authorised under any applicable bylaw, the Traffic Regulations 1976, Transit NZ Manual of Traffic Signs and Markings Pt1 - Traffic Signs and Pt2 - Markings, or Transit NZ Specification C2 1991 Temporary Traffic Control, or
- b) temporary signs painted on shop windows that relate to the activity on the premises, or
- c) the use of corporate colours painted on buildings as a means of identifying a premises except where subject to a design guide, or
- d) signs required to be erected under the Resource Management Act and Regulations for the purpose of public notification, or
- e) signs erected by the appropriate authority warning the public of health or safety concerns in the immediate vicinity, or
- f) any text or pictorial display advertising on or attached to any vehicle with a current registration and warrant of fitness, providing that it is not parked for the primary purpose of directing attention to any site, premises, commercial activity or vehicle sale.

Sign area

in relation to a multiple-sided sign, sign area is the area when viewed from any one direction, providing that the total area of all faces of a sign do not exceed twice that permitted in the following rules.

Sign height

means that measurement from the ground level at any point to the topmost part of the sign immediately above that point.

Three dimensional sign

means a sign having length, breadth and depth, or appearing to have length, breadth and depth by displaying the image as embossed in relief or similar, and includes a model of the logo, or the thing being advertised, as a sign, but does not include a cubiform shaped sign, such as sign box for an internally illuminated sign. See Illustration of this definition in Figure 1 below.

Figure 1: illustration of three dimensional sign definition.

Note: This figure is not to scale and does not illustrate all requirements in the rules.

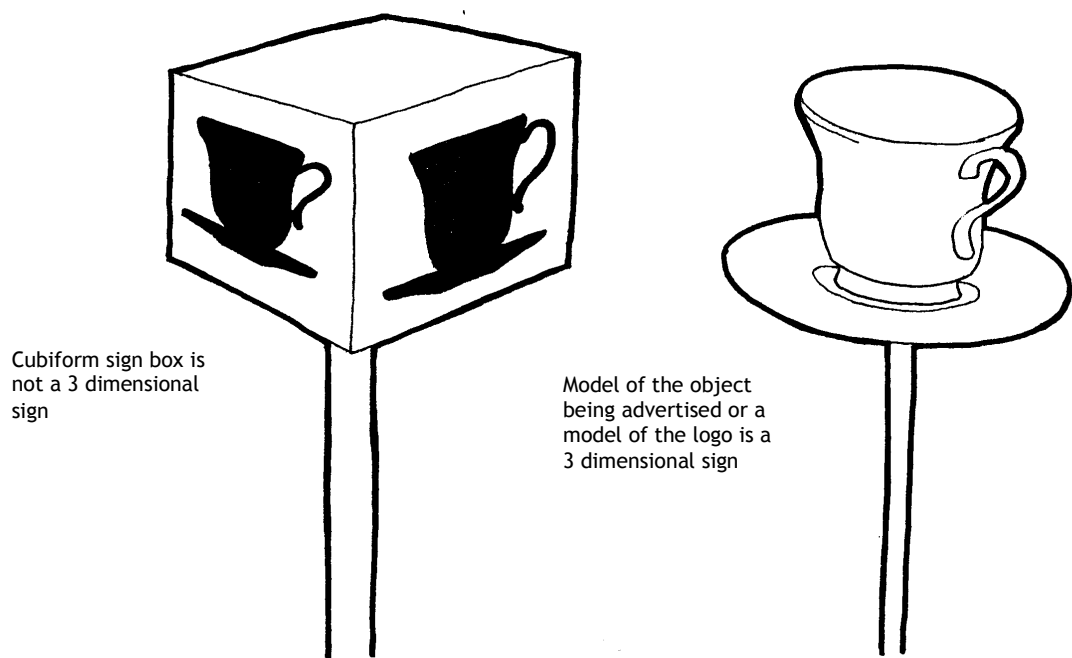

AP20.2 rules - table of standards

AP20.2.i The table of standards works the same way as every other Rule Table throughout the document, except that long rules and assessment criteria and explanations have been listed below the table and cross references added for ease of use. An explanation can be found at the beginning of each Rule Table in Chapters 7 to 14.

AP20.3 reading the rule table

AP20.3.i Each row of the Rule Table presents rules that regulate or allow one activity, or type of activity, or effect. Read along the row from left to right to determine whether a proposed activity is permitted, controlled, discretionary or non-complying. This progression across the Rule Table is called a “cascade.” (See flow chart below.)

AP20.3.ii If an activity satisfies the conditions stated in the permitted activity column, then it is permitted. If not, look to the next column (controlled). If it satisfies the standards and terms in the controlled column, it is a controlled activity. If not, then look at the next column (discretionary) to see if it fits the standards and terms stated there. If the activity satisfies the standards and terms in the discretionary column it is discretionary. Otherwise it is a non-complying activity.

In some instances where a rule is too long for a column or contains illustrations and tables these have been split from the Rule Table and listed below. In these cases cross references to the rule are made in the column and the link shown prominently in the text below the Rule Table.

AP20.3.iii Further explanation of the Rule Table and cascade is contained in Chapter 3 (administration).

AP20.3.iv The following flow chart illustrates the cascade across the Rule Table.

AP20.3.v

The General Assessment Criteria and The General Traffic Assessment Criteria are to be read in addition to any other assessment criteria, whether or not there is a listed cross reference to them.

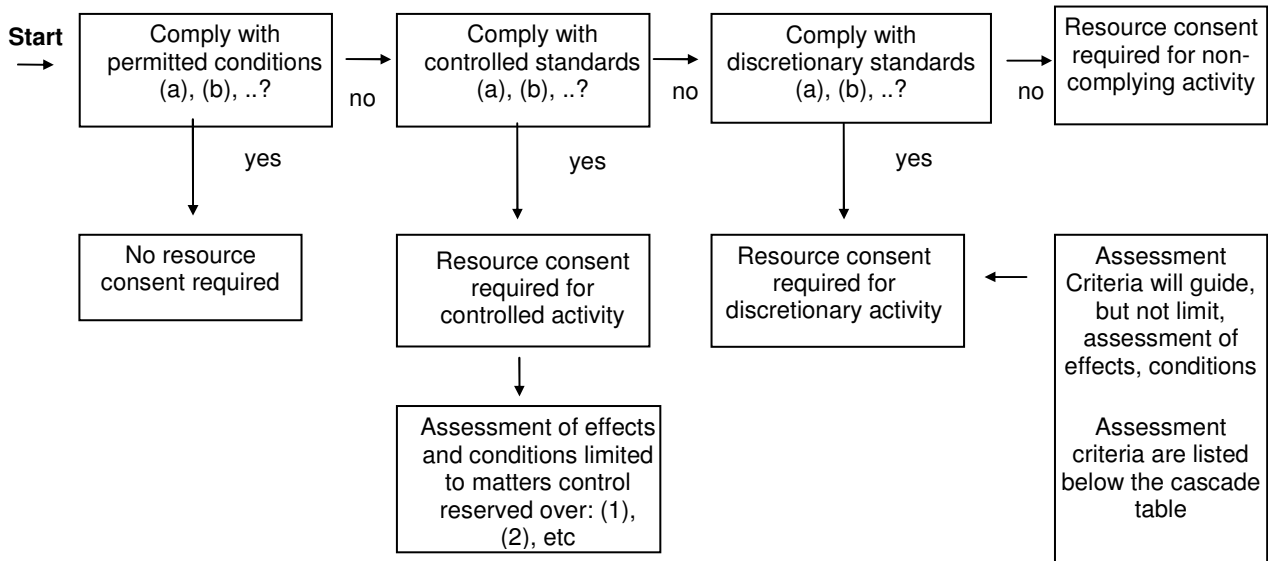

Contents of rule table: appendix 20

All Zones

AP20r.1	Signs other than those included in the following rules
AP20r.2	General
AP20r.3	Election signs (off site signs)
AP20r.4	Signs on heritage items, or listed trees
AP20r.5	Property sale and development signs
AP20r.6	Signs associated with reserves and community facilities

Rural Zone

AP20r.7	Signs in Rural Zone
---------	---------------------

Residential Zone

AP20r.8	Property name signs
AP20r.9	Home occupation signs
AP20r.10	Signs for non residential activities including places of public assembly, community use and places of worship

Inner City, Suburban Commercial, and Industrial Zones

AP20r.11	Free-standing advertising signs within a site
AP20r.12	Free-standing advertising signs for vehicle oriented commercial activities (excluding supermarkets and shopping malls) – see Chapter 2 (Meaning of Words)
AP20r.13	Projecting signs attached to buildings
AP20r.14	Signs attached to the underside of a verandah
AP20r.15	Signs painted on or attached parallel to buildings (including verandah fascia signs)

Coastal Marine Area and Conservation Zone

AP20r.16	Signs in the Coastal Marine Area and Conservation Zone
----------	--

Open Space and Recreation Zone

AP20r.17	Free standing traffic directional signs
AP20r.18	Advertising signs

AP20r.1 – AP20r.6 rules applying to all zones

AP20r.1 signs other than those included in the following rules

Item	Permitted	Controlled	Discretionary
AP20r.1 Signs other than those included in the following rules	AP20r.1.1 not applicable	AP20r.1.2 not applicable	AP20r.1.3 Any other sign type, dimension, situation, or sign operating method not otherwise provided for in the following rules of this appendix is a discretionary activity

AP20r.1.4 assessment criteria

AP20r.1.4.i General assessment criteria include but are not limited to:

- a) The degree of compliance with any applicable design guide.
- b) The degree to which the sign is in conformity with the principles and values contained in any overlay shown in respect of the site on the Planning Maps.
- c) The degree to which the sign is visually appropriate to the character and amenity of the existing area or the character and amenity of the area proposed under this Plan.
- d) Any positive effects on the visual vitality or environment of the area.
- e) The number of signs that are necessary to support the activity while maintaining Nelson's 'low sign' environment.
- f) The degree to which the sign is necessary to support the overall pattern of permitted development under this Plan.
- g) The quality of the sign design especially in relation to its maintenance (and therefore its accessibility).
- h) Any cumulative effects in relation to the above.

AP20r.1.4.ii General traffic assessment criteria include but are not limited to:

- a) The degree to which the sign may adversely affect traffic and pedestrian safety and visual amenity, especially in relation to:-
 - i) the type of traffic or pedestrians in the area.
 - ii) the degree to which adequate sight lines are maintained, especially where there are traffic or pedestrian conflicts.
 - iii) distraction of traffic or pedestrians at vehicle control points and traffic conflict points.
 - iv) distraction to users while on the road network.
 - v) the degree to which a sign may be confused with a traffic or pedestrian control or advisory sign (either during the day or nighttime or in adverse conditions).
 - vi) the extent to which any sign may obstruct traffic or pedestrian flow paths.
 - vii) the extent to which adequate overhead clearance is retained for the passage of the usual vehicles or pedestrians in the area.
 - viii) the intensity of activity on the road or pedestrian ways especially in relation to peak flows.
 - ix) the classification of the road in the road hierarchy.
 - x) any special considerations for children or the disabled.
 - xi) the driving environment.
- b) Any effects on aircraft or shipping navigation & safety.

AP20r.1.5 explanation

By their very nature signs depend on their effectiveness at capturing attention. To do this they use bright colours or forms which stand out from the background, and other strong visual signals. Sign types and methods are extremely varied and new developments in this type of advertising are on the increase.

Because under a predominantly effects based plan there is a much wider variety of activities that are possible, it is unlikely that 'activities list' based rules, such as these sign rules could cater for all possible activity types. These rules seek to address issues related to the major activities or the character of an area and give certainty wherever possible. However, sign types, dimensions, situations, or sign operating methods other than listed in these rules may still have adverse effects on the environment and these should be judged on those effects and on their merits. This rule is to ensure that this assessment takes place.

AP20r.2 location

Item	Permitted	Controlled	Discretionary
AP20r.2 General All signs are subject to these rules and assessment criteria	AP20r.2.1 Signs must: Comply with the permitted conditions listed below for:- i) Location ii) Design iii) external lighting iv) audible signs	AP20r.2.2 not applicable	AP20r.2.3 a) Activities that contravene a permitted condition are discretionary. b) Non compliance with AP20r.2.1.ii (l) (Design -Signs be maintained to a tidy and legible standard) will not require a resource consent. Condition i) is to be used for enforcement purposes. If condition i) is not complied with enforcement of the condition may be actioned.

AP20r.2.1 permitted conditions

AP20r.2.1.i Location

Signs must:

- a) be situated on the property at which the goods or services they advertise are available **except** for election signs (see Rule AP20r.3), signs permitted under AP20r.16.1 and signs under Controlled Activities in AP20r.7.2, and
- b) in the case of a freestanding sign, be located more than 10 m from any road intersection (except where attached to a building). Provided freestanding signs may be located within this area where such signs are clear and unobstructed (except for up to 2 posts necessary to structurally support the sign) up to 2.5m (minimum) in height* and also complies with Figure 2 (see over page), and
- c) except in relation to under verandah signs, where they are within 10m of any property access, be set back 1.5m from the front boundary of the site, or be less than 1m in height, and provided a sign may be located closer than 1.5m from the front boundary of the site if such signs:
 - i) are permitted in these rules to exceed or be placed at a height* greater than 2.5m, and
 - ii) are clear and unobstructed (except for up to 2 posts necessary to structurally support the sign) from 1m up to 2.5m (minimum) in height*, and
 - iii) for a free-standing sign, otherwise comply with Figure 2, and
- d) Not be a skysign (see definition), and

- e) not be erected on or overhanging road reserve or any public place, except in the Inner City, Suburban Commercial, and Industrial Zones, where a minimum clearance, between the bottom of the sign and the ground level or finished floor level, must be 4.4 m in areas used by vehicles, and 2.5m for areas used by pedestrians

Note Height must be measured from the carriageway level at the kerb closest to the sign.

Figure 2 illustration of rule AP20r.1.1.i b) – free standing sign to be located more than 10m from an intersection – conditions for location in this area

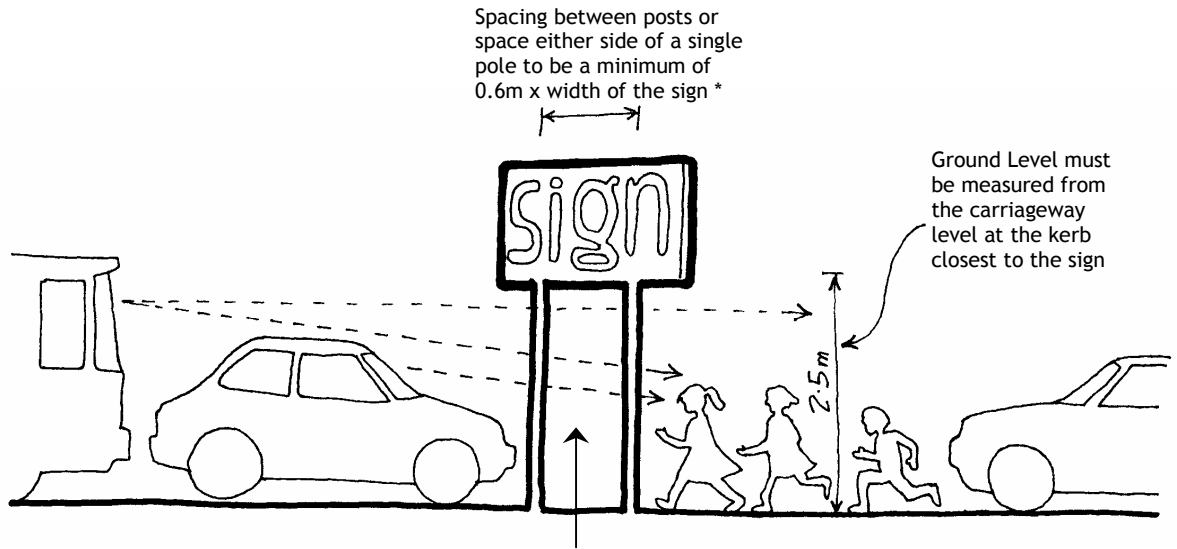

To allow visibility under the sign to approaching traffic, pedestrians and other objects, 2.5m above ground level must be kept clear and unobstructed. This allows drivers of vehicles including cars, buses and trucks to see under the sign to approaching traffic and pedestrians

*Refer Figure 7.11, Section 7 Guide Sign Mounting: Transit NZ- Manual of Traffic Signs and Marking-Part I-Traffic Signs-July 1994

Figure 3 illustrative figure of skysigns as defined in AP20.1

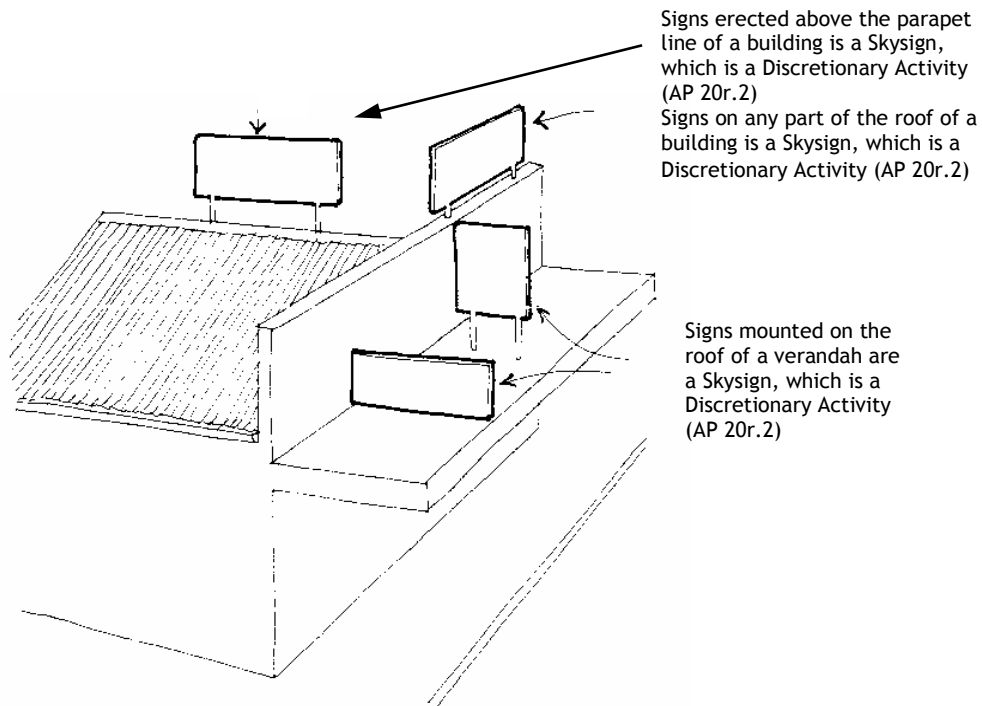

AP20r.2.1 permitted conditions continued

AP20r.2.1.ii Design

Signs must:

- a) not be 3 dimensional (see definition AP20.1 and Figure 1) or incorporate reflective materials, flashing illumination, aerial or moving display, and
- b) not mimic or conflict with the design, shape and, colour combinations of traffic control signs or signals, and
- c) where any sign, other than an under verandah sign, is within 20m of the nearest edge of a carriageway of a legal road and the sign message will be visible from that road:
 - i) be located to avoid reflecting headlights back into the motorists' vision by being positioned at off angle of 5 degrees from right angle to road frontage (provided this rule will take precedence over any other rule in the Appendix requiring a different sign orientation), and
 - ii) on roads classified in the Road Hierarchy (on Planning Map A2.1 and 2.2) as Principal, Arterial or State Highway (or proposed such roads),
 - a) have a maximum of five words or a combination of six words and symbols, and
 - b) have a letter height shown in Table AP20r.2.1 below, and
 - c) be sited at the distances shown in Table AP20r.2.1 below from regulatory traffic control signs including traffic lights, advance direction signs and guide signs
 - d) at all times be maintained to a tidy and legible standard that does not otherwise detract from the visual amenities of the area, and
 - e) be removed when no longer required, and
 - f) with the exception of its main support structure, not have the framework (See Figure 4) supporting the face of the sign visible when viewed from any road or public place.

Table AP20r.2.1 minimum letter height

Regulatory Speed Limit (km/h)	Main Message Upper case (mm)	Main Message Lowercase or Secondary Message Upper case (mm)	Secondary Message Lower Case (mm)	Minimum Vertical Space between words or symbols (mm)	Spacing between subject sign and any other regulatory traffic control sign (m)
50	150	75	37	110	50
70	200	100	50	150	55
80	250	125	62	185	70
100	300	150	75	225	80

Figure 4: illustration of 'framework' in rule AP20r.2.1.ii k) or f)

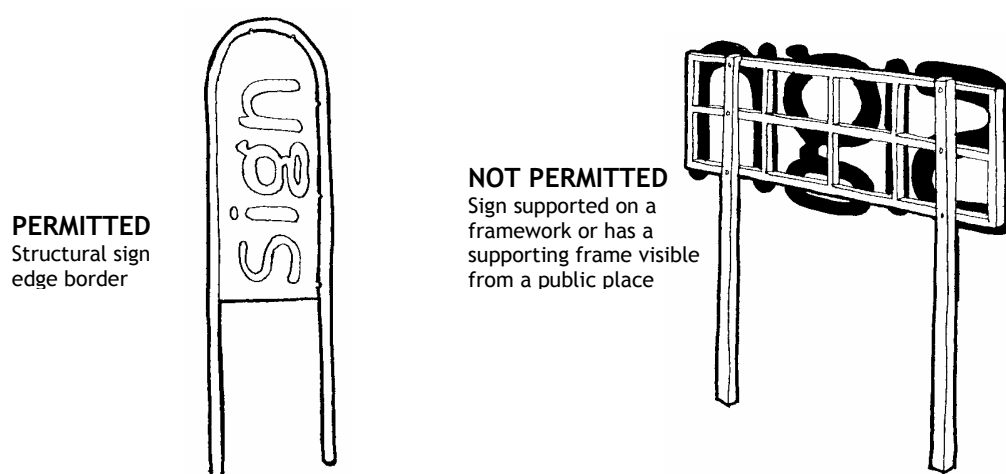

AP20r.2.1 permitted conditions continued

AP20r.2.1.iii External Lighting

Signs must:

- a) have any external lighting permanently fixed and directed solely at the sign, so it does not cause a distraction to pedestrians at traffic control points (such as pedestrian crossings), or drivers, or glare on other sites.

See Also: light spill rules: REr.46, ICr.45, SCr.35, INr.41, OSr.38 & CMr.54

AP20r.2.1.iv Audible Signs

Signs must:

- a) be designed to advertise only visually - see definition of 'Sign' at the beginning of this appendix. (Signs that advertise by means of sound are not a permitted activity).

AP20r.2.4 assessment criteria

This includes:

General Assessment Criteria AP20r.1.4.i , and: General Traffic Assessment Criteria AP20r.1.4.ii apply in addition to the assessment criteria below.

AP20r.2.4.i Location (refer AP20r.2.1.i (location))

- a) The degree to which the sign relates to activities in the nearby area.
- b) Any positive effects on traffic or pedestrian safety by directing traffic to the goods or services being advertised or by allowing traffic sufficient time to safely turn into a site.
- c) The extent of wider public benefit that would result from the sign being displayed.
- d) The number of signs already in the area in which the sign is proposed.
- e) The degree to which the location or design of the sign affects visual clutter in the area.
- f) The degree of the sign's visual incongruity in relation to the:
 - i) context of the area (context relates to the form of the sign in relation to its surroundings).
 - ii) The content of the sign in relation to nearby activities (for instance an advertisement for a gaming activity outside a church may be considered incongruous in that area but not in an area devoted to tourism or an highly commercial activity in a residential area).
- g) Any cumulative effects relating to any of the above.

Location of skysigns (refer Ap20r.2.i d)

- a) The extent to which the skysign and its supporting structure will disrupt or dominate the:
 - i) architectural integrity of a building or structure,
 - ii) architectural features of the street façade,
 - iii) foreground or background of the townscape, streetscape, skyline and/ or landscape (at any time: day or night),
 - iv) the existing scale of the area or the scale of the area intended under this Plan.
- b) The degree to which the skysign would seem to unduly enclose the area.
- c) The degree to which the skysign is contained within the silhouette of the building.
- d) The degree to which the skysign will prevent advertising of existing signs.
- e) The degree to which the skysign may prevent potential advertising in complying positions.
- f) The degree to which the skysign will have the same or similar effects to a complying sign.
- g) Any cumulative effects relating to any of the above.

AP20r.2.4.ii Assessment criteria for design - 3 dimensional signs

- a) The degree to which the 3 dimensional sign will have the same or similar effects to a complying sign
- b) The extent to which the 3 dimensional sign and its supporting structure will disrupt or dominate the:
 - i) architectural integrity of a building or structure,
 - ii) architectural features of the street façade,
 - iii) foreground or background of the townscape, streetscape and/ or landscape (at any time: day or night).
- c) Any positive or adverse effects from a 3 dimensional sign not having a background structure.
- d) Any cumulative effects relating to any of the above.

AP20r.2.4.iii Assessment Criteria for External Lighting

- a) The type of light and its effects including its intensity, light spread, colour, flash rate and times of operation.
- b) The effect on traffic safety especially the degree to which the lighting may dazzle drivers or pedestrians.
- c) The effect on aircraft or shipping navigation & safety.
- d) The degree to which the lighting may adversely affect the occupation or enjoyment of, or operations or activities on, any nearby site.
- e) Any cumulative effects relating to any of the above.
- f) Any design features of the light which may mitigate any of the adverse effects (e.g. light shielding).

AP20r.2.4.iv Assessment Criteria for Audible Signs

- a) The nature and type of sign and its effects on the occupation or enjoyment of, or operations or activities on, any nearby site or service network.
- b) The nature and location of nearby activities and the effects they may experience
- c) Whether the sign or sign method will or is likely to detract from the general environmental quality.
- d) Any cumulative effects relating to any of the above. Also see AP20r.1.4 (general assessment criteria and general traffic assessment criteria).

AP20r.2.5 explanation

AP20r.2.5.i Location

AP20r.2.1.i

In order to maintain the City's 'low sign' environment, avoid a proliferation of signs throughout the district and achieve a fair system of allocating space to signs, it is essential that signs only locate on the properties to which they relate. In general only where there is wider public benefit have off site signs been permitted.

Note - Cross reference: See ICr.56 (view shaft overlay).

Exceptions to AP20r.2.1.i a)

Signs must be situated on the property at which the goods or services they advertise are available. Exception is election signs (see AP20r.3) Cross reference in relation to AP20r.2.1.i b) Sign setbacks from intersections: See also REr.29 (corner sites) and ICr.34 (building setback - corner sites).

Note - Cross reference: In relation to AP20r.2.1.i c): Sign Setbacks for accessways: see also REr.30 (buildings and fences near vehicle accesses).

Location of skysigns (refer AP20r.2.1 d)

Skysigns have the potential, because of their position, to significantly alter the form of a building and, cumulatively, an area. Skysigns may have particularly pronounced effects on sensitive views, landscapes and the skyline. Building and sign designers need to take particular care to retain or minimise the effects on such values. Generally skysigns are less intrusive when they fall within the silhouette of a building or structure or extend the inherent form of the structure or its background.

Notes relating to skysign assessment criteria:

Scale - is not only size but the inherent claim to size that the structure makes to the eye.

Enclosure - relates to the effect a sign will have on the human scale of a place. The place should ideally be, or have predominant elements, at human scale. Consequently, if there is an existing sense of enclosure a person should continue to feel comfortable within it. Conversely, if the area is more open, then that openness should be retained. Cumulative effects are particularly important.

Signs for the Department of Conservation - Section 4 Resource Management Act 1991

Section 4 (3) of the Act provides that Section 9 (1) does not apply to any work or activity of the Crown within the boundaries of any area of land held or managed under the Conservation Act 1987 that is consistent with a conservation management strategy, conservation management plan established under the Conservation Act 1987 or other specified act and does not have a significant adverse effect beyond the boundary of the area of the land.

Plan users considering such signs should refer to Section 4(3) of the Act and may also refer to the Department of Conservation, Outdoor Signs Manual (ISBN: 0-478-01512-7)

AP20r.2.5.ii Design

3 dimensional signs may tend to dominate an area more than a sign board due to their depth perception. However, sometimes such signs can have less visual impact on an area where there is no backing board or structure to the lettering or shape.

3 dimensional signs which present a similar perception of size as a complying sign board in a similar situation will generally be acceptable.

Signs must at all times be maintained to a tidy and legible standard.

Signs have the potential to cause visual pollution if not maintained to a standard in keeping with the quality and context of an area. Enforcement action may be taken if signs are not maintained to the quality and context of the area, both in their advertisement area or structure, or if they become illegible.

Figure 5: Explanatory Figure: some of the requirements for a sign, other than an under verandah sign, which is within 20m of the nearest edge of a carriageway of a legal road and the sign will be visible from that road (AP20r.2.1.ii c)

Note: This figure is not to scale and does not illustrate all requirements in the rules

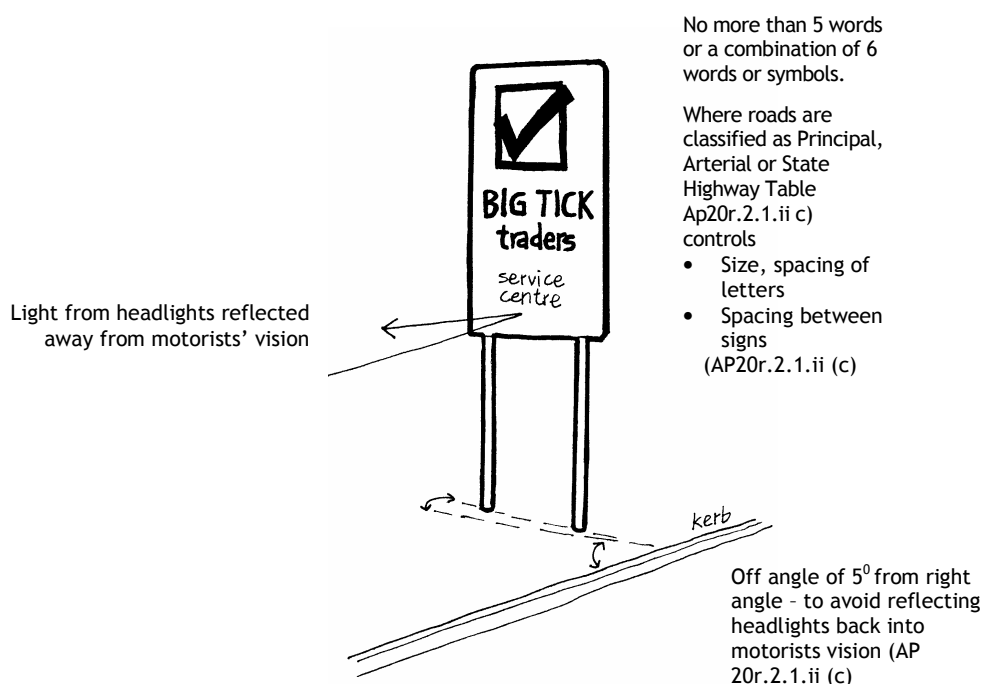

AP20r.2.5 explanation

AP20r.2.5.iii External Lighting

This rule is to prevent light spill hazards to road users and pedestrians and to avoid nuisance light spill onto neighbouring properties. Motorcyclists are particularly prone to dazzle due to the acrylic lenses on goggles and crash helmet visors.

In Residential areas light spill can interfere with people's sleep and their enjoyment of their property. Dazzle and light spill can also be a hazard or nuisance for people at their workplaces.

AP20r.2.5.iv Audible Signs

There is a growing trend for public outdoor advertising by other than visual means. For example broadcasting recorded messages from commercial premises.

This rule aims to acknowledge this trend while avoiding any potential to create individual or cumulative nuisance effects or jeopardise the safety of essential networks.

Each case needs to be considered on its merits as a discretionary activity.

AP20r.3 election signs

Item	Permitted	Controlled	Discretionary
AP20r.3 Election signs (off site signs)	AP20r.3.1 Signs for electioneering purposes in all zones, are permitted subject to compliance with Ap20r.3.1 (permitted conditions).	AP20r.3.2 not applicable	AP20r.3.3 Activities that contravene a permitted condition are discretionary.

AP20r.3.1 permitted conditions

- a) maximum number: a total of 10 signs throughout the District (all zones) per candidate, and
- b) maximum area: 0.75m² per sign, and
- c) maximum height: 2m, and
- d) letter size:
 - i) on legal roads shown in the Road Hierarchy as a local road, sub - collector or collector road the minimum vertical height of lettering must be 150mm, with a 100mm vertical gap between lines, or
 - ii) on legal roads shown in the Road Hierarchy as a Principal, Arterial or SH6, the minimum vertical height of lettering must be 200mm, with a 100mm vertical gap between lines (where a legal road does not appear on the Road Hierarchy it shall be deemed to be a local road), and
- e) duration - such signs may be erected no more than 2 months before the election, and removed prior to the day of the election being held, and
- f) where electioneering signs are to be positioned along the State Highway, written consent must first be obtained from the NZ Transport Agency or, within the 50km/hr zone, Nelson City Council. (This consent must be lodged with the Divisional Manager of Planning & Consents prior to signs being erected.) and
- g) except as provided for in f) above, no sign may be placed on or over the legal road reserve, and
- h) no sign may be erected or dismantled between the hours of 7pm and 7am.

AP20r.3.4 assessment criteria

- a) The degree to which the sign/s will obscure other nearby election signs and other signs.

Also see general assessment criteria (AP20r.1.4.i) and general traffic assessment criteria (AP20r.1.4.ii).

AP20r.3.5 explanation

Note - The content and removal of electioneering signs may otherwise be dictated by legislation.

Any detracting from amenities caused by election signs is limited and temporary, and is outweighed by the community interest in receiving information about candidates or parties for elections.

Consent to erect signs under this Plan does not override the rights of the owner of land or the controlling authority of a road on which signs are erected, to allow their placement or order their removal.

AP20r.4 signs on heritage items

Item	Permitted	Controlled	Discretionary
AP20r.4 Signs on heritage items, or listed trees	AP20r.4.1 Signs on Group A or B heritage items listed in Appendix 1, or Heritage or Landscape Trees listed in Appendix 2, are not permitted except for: a) plaques or signs not exceeding 0.2 m ² which identify the item, or b) signs on Group A or B Heritage Buildings listed in Appendix 1 are permitted if: i) the sign complies with the rules set out in this Appendix, and ii) the sign is not above verandah level, or where there is no verandah, is not above 4 m from ground level, and iii) the sign does not obscure any window, or architectural or decorative feature on the building.	AP20r.4.2 Signs on Group A or B Heritage Buildings listed in Appendix 1 which contravene either permitted condition (b) i or ii are controlled, if: a) the sign does not obscure any window, or architectural or decorative feature on the building. Control reserved over: i) the size and location of the sign. ii) the design and appearance of the sign.	AP20r.4.3 Signs that contravene a permitted condition or controlled standard or term are discretionary.

AP20r.4.4 assessment criteria

- a) Whether the sign will detract from or add to the heritage item and its surrounds.
- b) The purpose of the sign.
- c) The level of compliance with any guidelines in heritage precincts.

AP20r.4.5 explanation

Small signs, which identify the item, are permitted on Heritage and Landscape Trees, and on Heritage Places and Objects.

Signs on Heritage Buildings are controlled when they are above verandah height only, as below verandah level heritage buildings are often quite modified especially when they are used for commercial purposes. Signs above verandah level can be more intrusive, and can detract from, or obscure, heritage features.

Signs on verandah fascias can also detract from heritage values, but these have not been regulated. However, care in the size and design and appearance of such signs is encouraged, so that they fit with the heritage values of the building.

AP20r.5 property sale and development signs

Item	Permitted	Controlled	Discretionary
AP20r.5 Property sale and development signs	AP20r.5.1 Property sale signs Signs must comply with the provisions listed in AP20r.5 (property sale signs) subject to the provisions listed in AP20r.5.1 (permitted conditions). Site redevelopment Signs must comply with the provisions listed in AP20r.5.1.ii (permitted conditions).	AP20r.5.2 not applicable	AP20r.5.3 Activities that contravene a permitted condition are discretionary and any other property, development or temporary sign not otherwise provided for in the rules of this Appendix is a discretionary activity.

AP20r.5.1 permitted conditions

AP20r.5.1.i Property sale signs

- a) not exceed 2m in height, and
- b) in zones **other than** Inner City-Fringe, Inner City-Centre, Suburban Commercial or Industrial, not exceed 1m², and
- c) in zones Inner City-Fringe, Inner City-Centre, Suburban Commercial or Industrial not exceed 3m² and have a maximum dimension of 1.2m by 2.5m, and
- d) be displayed only while the property is on the market, and must be removed as soon as the sale is completed, and
- e) be erected within the site advertised on the sign.

AP20r.5.1.ii Site redevelopment

- a) not exceed 2m in height, and
- b) not exceed 2m², and
- c) be erected no sooner than 2 months prior to construction works commencing, and be removed within 5 days of construction being completed, and
- d) be erected within the site advertised on the sign.

AP20r.5.4 assessment criteria

- a) The relationship of the sign to the site.
- b) The size of the sign and information to be displayed.
- c) The length of time the sign will be on the site.
- d) The purpose of the sign.
- e) The impact of signage on the streetscape and general amenity of the area.
- f) The effects on traffic safety.

AP20r.5.5 explanation

Signs on the road reserve must not compromise vehicle safety and driver visibility.

AP20r.6 signs associated with reserves and community facilities

Item	Permitted	Controlled	Discretionary
AP20r.6 Signs associated with reserves and community facilities	AP20r.6.1 Signs must: a) not exceed 2 m in height, and b) not exceed 1.5 m ² , and c) be limited to one sign per road frontage.	AP20r.6.2 not applicable	AP20r.6.3 Activities that contravene a permitted condition are discretionary.

AP20r.6.4 assessment criteria

- a) Sign standards in the adjacent zone.
- b) The impact on the streetscape of the area.
- c) The effects on traffic safety.
- d) The need for additional or oversized signs.

AP20r.6.5 explanation

Some signage may be required on public and community facilities, particularly to advertise the availability/locality of any particular facility, venue, or sporting complex or code. Excessive signage may however detract from the surrounding area or the facility itself.

AP20r.7 – AP20r.18 rules applying only within the relevant zone

AP20r.7 rule applying to the rural zone

AP20r.7 signs in rural zones

Item	Permitted	Controlled	Discretionary
AP20r.7 Signs in the Rural Zone	AP20r.7.1 Signs must comply with AP20r.7.1 (permitted conditions).	AP20r.7.2 More than one sign per property is a controlled activity if they comply with AP20r.7.2 (controlled standards and terms). Signs associated with an approved activity under a Department of Conservation: Conservation Management Strategy or Conservation Management Plan are a controlled activity if they comply with AP20r.7.2 (controlled standards and terms). Control is reserved over: <ol style="list-style-type: none"> the number of signs on the property, for signs on legal road, the number of signs that are visible in the locality, the design of the sign, the location on the site, the clarity and visibility of the sign for approaching traffic and the safety of the road network. The size of the sign in relation to rural character and amenity. 	AP20r.7.3 A Freestanding sign associated with a Vehicle Oriented Commercial Activity (excluding a supermarket or shopping mall) permitted under rule RUr.20.1 b),c),d) e) is a restricted discretionary activity if there is no more than one sign per property and complies with AP20r.7.3 (discretionary standards). Discretion is restricted to: <ol style="list-style-type: none"> the design of the sign, the location on the site, the clarity and visibility of the sign for approaching traffic and the safety of the road network, the size of the sign in relation to rural character and amenity Activities that contravene a <ol style="list-style-type: none"> permitted condition, or controlled standard or term, or restricted discretionary standard or term, are discretionary activities.

AP20r.7.1 permitted conditions

One sign per property which must:

- display no more than a total of 6 words and symbols, and
- be located no closer than 70m from any other sign, and
- be a minimum of 3m back from the road boundary, and
- not be a sign associated with any Vehicle Oriented Commercial Activity permitted under rules RUr.20.1 b),c) d) or e) of greater area than permitted in f), g) or h) below, and
- not be in or within 200m of a Landscape Overlay, and

- f) signs within 50m of any formed legal road with a regulatory speed limit of 50km/hr or less or signs greater than 50m from any formed legal road must:
 - i) not exceed 2m in height, and
 - ii) not exceed 1m² plus a detachable “open/closed” panel of not more than 0.2m², and
- g) signs within 50m of any formed legal road with a regulatory speed limit of over 50km/hr and up to 80km/hr, must:
 - i) not exceed a height of 2m, and
 - ii) not exceed 2m² plus a detachable “open/closed” panel of not more than 0.2m², and
 - iii) have a minimum lettering height for the main message of 250mm and 125mm for a secondary message. and
- h) signs within 50m of any formed legal road with a regulatory speed limit of over 80km/hr, must:
 - i) not exceed a height of 2.5m, and
 - ii) not exceed 3m², and
 - iii) have a minimum lettering height for the main message of 250mm and 160mm for a secondary message
- i) the minimum height of lettering in rules f), g) and h), above, shall take precedence over the equivalent rule & vertical space between words or symbols rule, shown in Table 20r.12 of this Appendix.

AP20r.7.2 controlled standards and terms

AP20r.7.2.i More than one sign per property is a controlled activity if:

- a) the sign is for the purpose of advising the public of safety conditions, hazards, or public amenity areas, and
- b) the sign does not advertise goods, services, trade names or marks, and
- c) otherwise meets the permitted conditions of AP20r.7.1

AP20r.7.2.ii Signs associated with an approved activity under a Department of Conservation, Conservation Management Strategy or Conservation Management Plan are a controlled activity if

- a) such signs located on the legal road have the prior written approval of the road controlling authority, and
- b) such signs located on the legal road are ‘information signs’ as defined in the Department of Conservation Outdoor Sign Manual: Edition number 1, September 1994 (ISBN:0-478-01512-7), and
- c) such signs are not located in or within 200m of a Landscape Overlay, and
- d) such signs are otherwise in accordance with the Department of Conservation Outdoor Sign Manual: Edition number 1, September 1994 (ISBN:0-478-01512-7)

AP20r.7.3 discretionary standards

- a) not be in or within 200m of a Landscape Overlay, and
- b) not exceed 7.5m in height, and
- c) not exceed 7m², and
- d) the sign is located completely within the site to which that sign relates, and
- e) be on a property which does not adjoin a Residential Zone, and
- f) be located no closer than 70m from any other advertising sign on an adjoining site, and
- g) any sign adjoining the state highway has the prior written consent of the state highway road controlling authority.

AP20r.7.4 assessment criteria

- a) The location of the sign with respect to the carriageway of the road.
- b) The scale, content and purpose of the sign.
- c) Effects on the appearance of the area, and any potential impacts on traffic safety.
- d) Other signage on site, cumulative effects, and any opportunity to co-locate signs.
- e) The readability of the sign to passing traffic.
- f) The location of the sign in relation to pull-off areas and deceleration lanes on busy roads.
- g) The impact of signage on traffic flows, particularly close to intersections.
- h) The distance to the site of the activity being promoted (the need for repeat signs for distant signs should generally be avoided).
- i) Whether any signs exist at present on the site or intersection, and the cumulative effect of those signs on the visual environment.
- j) The height and display area of the sign, and the information to be presented on the sign, and its readability to passing traffic.
- k) Necessity of the sign for achieving AP20r.7.2 a) above (advising the public of safety conditions, hazards, or public amenity areas).

Landscape Overlay:

- l) The extent of compliance with the guidelines in Appendix 7 (guide for subdivision and structures in the landscape overlay) relating to structures
- m) The impact of the sign on the view and landscape as described in Appendix 9 (landscape components and views)
- n) Mitigation measures proposed to minimise impacts on the area within the Landscape Overlay

AP20r.7.5 explanation

The limitation on distance between signs on adjacent properties is to avoid excessive distraction and cumulative effects of a proliferation of signs in the vicinity.

The size provided for acknowledges that traffic is often travelling at speed in rural areas and larger signs may be required to transmit information quickly without undue distraction.

This rule provides for signs to direct visitors to tourist or public facilities and sites located away from but within reasonable proximity to main thoroughfares.

Limitation on the number and size of such signs seeks to avoid a proliferation of directional signs and to ensure that those that are erected do not function purely as advertising. Commercial operators in such locations will otherwise be encouraged to advertise through alternative means such as public information kiosks, newspapers or electronic media.

The controlled activity rules recognise that there is a need for public information signs such as warnings for fire danger and the location of picnic and rest areas.

Signs for the Department of Conservation - Section 4 Resource Management Act 1991

Section 4 (3) of the Act provides that Section 9(1) does not apply to any work or activity of the Crown within the boundaries of any area of land held or managed under the Conservation Act 1987 that is consistent with a conservation management strategy, conservation management plan established under the Conservation Act 1987 or other specified act and does not have a significant adverse effect beyond the boundary of the area of the land.

Plan users considering such signs should refer to Section 4(3) of the Act and may also refer to the Department of Conservation, Outdoor Signs Manual (ISBN: 0-478-01512-7)

AP20r.8 – APr.20r.10 rules applying to the residential zone

AP20r.8 property name signs

Item	Permitted	Controlled	Discretionary
AP20r.8 Property name signs	AP20r.8.1 One sign per property which must: a) not exceed 2m in height, and b) not exceed 0.25m ² .	AP20r.8.2 not applicable	AP20r.8.3 Activities that contravene a permitted condition but which do not exceed 1m ² in area are discretionary.

AP20r.8.4 assessment criteria

- The location of the sign with respect to the carriageway of the road.
- The scale, content and purpose of the sign.
- Effects on the appearance of the area, and any potential impacts on traffic safety.
- Other signage on site, cumulative effects, and any opportunity to co-locate signs.

AP20r.8.5 explanation

Property name signs can be helpful to identify a particular site or premises. Such signs only need to be large enough to indicate the location, and are not intended to be used as advertising.

APr.20.9 home occupation signs

Item	Permitted	Controlled	Discretionary
AP20r.9 Home occupation signs	AP20r.9.1 One sign per property which must: not exceed 2m in height, and not exceed 0.5m ² .	AP20r.9.2 not applicable	AP20r.9.3 Activities that contravene a permitted condition but which do not exceed 1m ² in area are discretionary.

AP20r.9.4 assessment criteria

- The location of the sign with respect to the carriageway of the road.
- The scale, content and purpose of the sign.
- Effects on the appearance of the area, and any potential impacts on traffic safety.
- Other signage on site, cumulative effects, and any opportunity to co-locate signs.

AP20r.9.5 explanation

Home Occupation signs can be helpful to identify a particular site, business activity or premises. Such signs only need to be large enough to indicate the location, and balance the need to advertise the business location with the need to maintain the residential character and amenity in the residential area.

Ap20r.10 signs for non-residential activities

Item	Permitted	Controlled	Discretionary
AP20r.10 Signs for Non Residential Activities (including places of public assembly, community use and places of worship)	AP20r.10.1 One sign per property which must: a) not exceed 2m in height, and b) not exceed 1m ² .	AP20r.10.2 not applicable	AP20r.10.3 Activities that contravene a permitted condition are discretionary

AP20r.10.4 assessment criteria

The degree to which the sign is consistent with the relevant assessment criteria of REr20.4 (non residential activities).

Also see general assessment criteria (AP20r.1.4.i) and general traffic assessment criteria (AP20r.1.4.ii).

AP20r.10.5 explanation

Signs have the potential to significantly affect the form and character of an area. As such applications for signs for non residential activities should, where practicable, be assessed at the same time and on the same basis as the activities themselves.

Figure 6: Explanatory Figure: some of the requirements of signs in the Residential Zone

Note: This figure is not to scale and does not illustrate all requirements in the rules.

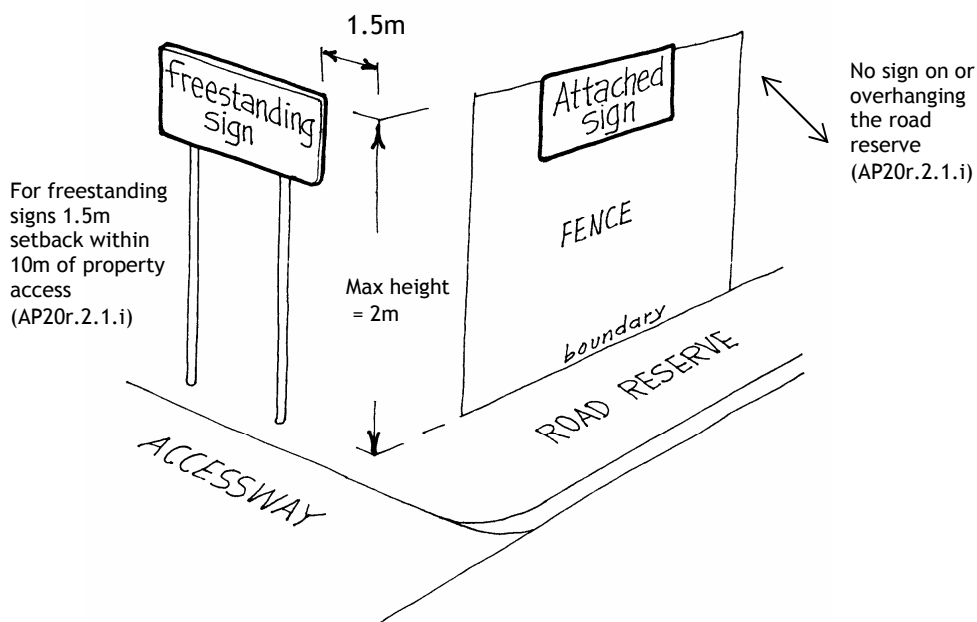

Figure 7: Residential Zone – Sign Area Comparisons

Note: This figure is not to scale and does not illustrate all requirements in the rules. This figure is intended as an aid to plan users to gauge the permitted size of signs in the Residential Zone.

Comparative Permitted Condition Sign Areas and Rule References

- Permitted area of property name sign (0.25m²) - AP20r.8.1
- Permitted area of home occupation signs (0.5m²) - AP20r.9.1
- Permitted area of non residential activities signs (1m²) - AP20r.10.1

Note: Different dimensions than those shown below are permitted under the rules.

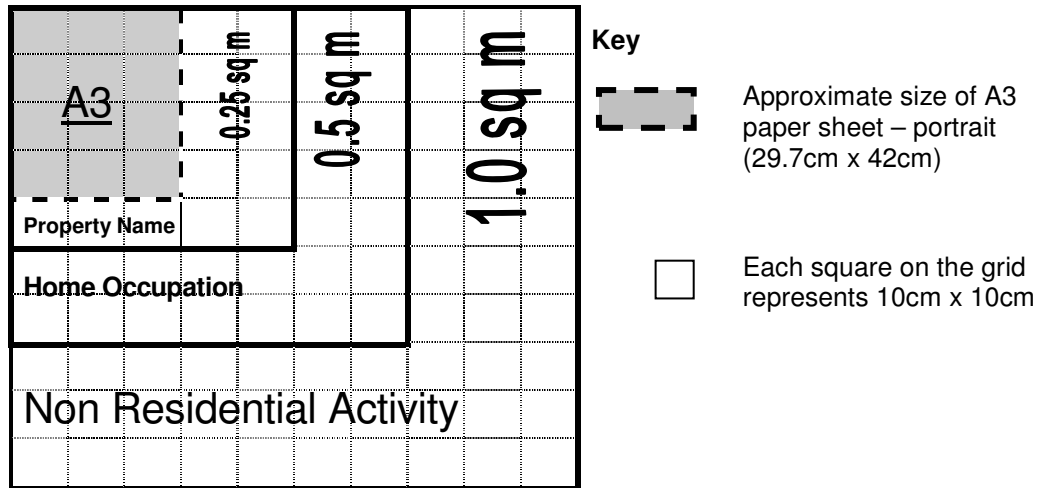

AP20r.11 – Apr.20r.15 rules applying to the inner city, suburban commercial and industrial zones

AP20r.11 free standing advertising signs within a site

Item	Permitted	Controlled	Discretionary
AP20r.11 Free-standing advertising signs within a site	AP20r.11.1 Free standing signs are permitted if they comply with AP20r.11.1.i (permitted conditions).	AP20r.11.2 not applicable	AP20r.11.3 Activities that contravene a permitted condition are discretionary if: a) signs do not exceed 8m ² . Signs greater than 8 m ² are non-complying.

AP20r.11.1 permitted conditions

- a) there is not more than one sign per road frontage (including freestanding vehicle oriented commercial activity signs - see AP20r.12), and
- b) the sign does not exceed 6m in height, and
- c) the sign does not exceed 4.5m², and
- d) the sign is located completely within the site that the sign relates to, and

Where freestanding signs are for the purpose of directing traffic within a site they must:

- e) not exceed 1m in height, and
- f) not exceed more than 0.5m², and
- g) be limited to directional arrows and “entry” or “exit” or equivalent terminology, and
- h) be placed completely within the site.

Note AP20r.11.2 and AP20r.11.3 are found within the rule table AP20r.11

AP20r.11.4 assessment criteria

- a) The location of the sign with respect to the carriageway of the road.
- b) The scale, content and purpose of the sign.
- c) Effects on the appearance of the area, and any potential impacts on traffic safety.
- d) Other signage on site, cumulative effects, and any opportunity to co-locate signs.
- e) Traffic safety benefits of having larger, taller or additional signage.
- f) Amenity effects on the surrounding area.

AP20r.11.5 explanation

Within these zones the Council accepts the need for locational advertising signs. It is important however that these signs be kept within limits to avoid unnecessary impacts on the appearance of the street.

The need for signage to direct vehicles to car parks or in a particular direction is accepted. These signs should generally be no larger than they need to be, and care needs to be taken with the surrounding environment to ensure that too much or confusing advertising does not eventuate, which is a distraction to passing traffic.

Figure 8: Freestanding Signs Rules in Inner City, Suburban Commercial and Industrial Zones

Note: This figure is not to scale and does not illustrate all requirements in the rules. For rules for Freestanding Signs for Vehicle Oriented Commercial Activities see AP20r.12

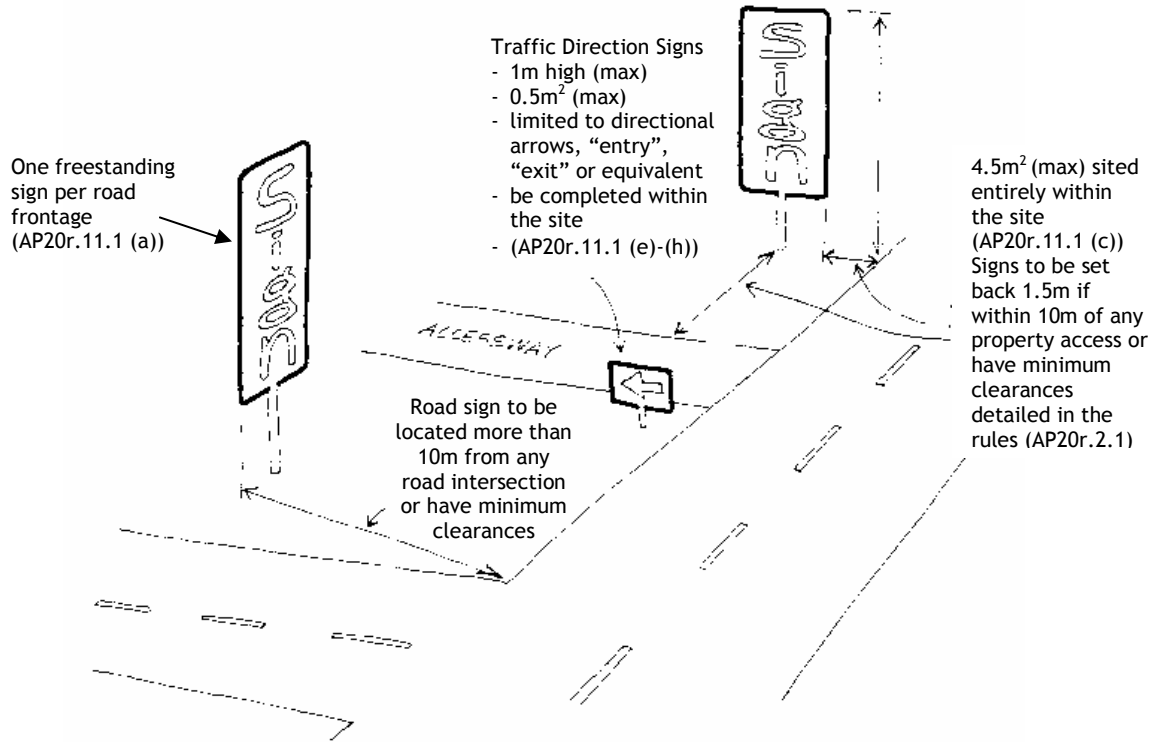

Table AP20r.12	Permitted	Controlled	Discretionary
AP20r.12 Free-standing advertising signs for vehicle oriented commercial activities (excluding supermarkets and shopping malls) – see Meaning of Words	AP20r.12.1 Free-standing Advertising signs for Vehicle Oriented Commercial Activities (excluding supermarkets and shopping malls) are a permitted activity if they comply with AP20r.12.1 (permitted conditions).	AP20r.12.2 Not applicable	AP20r.12.3 Activities that contravene a permitted condition are a Restricted Discretionary Activity if: they comply with AP20r.12.3 (restricted discretionary standards and terms). Discretion is restricted to: a) the design of the sign, and b) the total number of signs on the site, and c) the location on the site, and d) the clarity, and readability of the sign for approaching vehicular traffic. Resource consent applications for a restricted discretionary activity will be considered without notification or obtaining the written approval of persons, under Section 94 of the Act. Activities that contravene a restricted discretionary activity are a discretionary activity.

AP20r.12.1 permitted conditions

- a) there is not more than one such sign (including freestanding signs) per road frontage. (Provided traffic directional signs in accordance with AP20r.11.1 shall not be counted in this limitation), and
- b) the sign does not exceed 7.5m in height, and
- c) the sign does not exceed 12m², and
- d) the sign is located completely within the site to which that sign relates, and
- e) the site to which the sign relates does not adjoin the Residential Zone, and
- f) the site to which the sign relates is located on a road which is a principal, arterial or SH6 (or proposed principal or proposed SH6) shown on the road hierarchy maps A2.1 or A2.2, and
- g) the sign message must be limited to a maximum of five words or a combination of words and symbols to be not more than six, and
- h) the lettering of any such words be in a plain, easily read lettering style, and
- i) the height of the lettering conform with the conditions shown in Table AP20r.12.2 below.

(Note: a 'word' includes a group of figures and that make up a price e.g.:\$0.49/l equal one word).

Table AP20r.12.2 minimum letter height in mm

Regulatory Speed Limit (km/h)	Main Message Upper case	Main Message Lowercase or Secondary Message Upper case	Secondary Message Lower Case	Minimum Vertical Space between words or symbols (mm)
50	150	75	37	110
70	200	100	50	150
80	250	125	62	185
100	300	150	75	225

AP20r.12.3 restricted discretionary standards and terms

- a) the sign is a freestanding sign for a vehicle oriented commercial activity (excluding supermarkets and shopping malls), and
- b) the sign does not exceed 14m², and
- c) the sign does not exceed 9m in height, and
- d) there are no more than two such signs (including freestanding signs) per road frontage. (Provided traffic directional signs in accordance with AP20r.11.1 shall not be counted in this limitation), and
- e) the site to which the sign relates does not adjoin the Residential Zone, and
- f) on any site adjoining a state highway the prior written consent of the state highways road controlling authority is obtained

AP20r.12.4 assessment criteria**Restricted discretionary activities**

- a) The degree to which the design of the sign contributes to the readability of the sign for approaching traffic.
- b) The degree to which the design of the sign contributes to the pleasantness of the area.
- c) The location of the sign with respect to the carriage way of the road and the degree to which the sign is related to the main vehicle access to the site.
- d) Other signage on site, cumulative effects, and any opportunity to co-locate signs.

Discretionary activities

- e) The location of the sign with respect to the carriageway of the road.
- f) The scale, content and purpose of the sign.
- g) Effects on the appearance of the area, and any potential impacts on traffic safety.
- h) Other signage on site, cumulative effects, and any opportunity to co-locate signs.
- i) Traffic safety benefits of having larger, taller or additional signage.

AP20r.12.5 explanation

Within these zones the Council accepts the need for location advertising signs for activities which have a high degree of association with motor vehicles. It is important however that these signs be kept within limits to avoid unnecessary impacts on the appearance of the street and neighbourhood and the safety of the road network.

These signs should generally be no larger than they need to be, and care needs to be taken with the surrounding environment to ensure that too much or confusing advertising does not eventuate, which is a distraction to passing traffic.

These signs, at the maximum, are over three times the area of standard freestanding signs. This presents opportunity for co location of signs onto one well designed prime sign.

Care is needed when these larger freestanding signs locate next to lower intensity development, especially residential areas, in order to retain residential character, scale and amenity.

Information Notes

Useful references for advertising designs and road safety include:-

- a) LTSA & Transit NZ (1993) Road & Traffic Standards (RTS) no 7 - Advertising Signs and Road Safety: Design & Location Guidelines
- b) Land Transport Transit NZ (1994 Interim) - Manual of Traffic Signs and Marking
- c) Transit NZ (1994) Planning for a safe and Efficient Highway Network Under the Resource Management Act 1991
- d) LTSA (1996) Road Safety Guidelines for Service Stations)-RTS13
- e) Examples of fonts with good legibility (from RTS No 7 part 11.4 pg. 44) Helvetica, Universe, Paddington, Frankfurter, Tabasco, Optima

AP20r.13 projecting signs attached to buildings

Item	Permitted	Controlled	Discretionary
AP20r.13 Projecting signs attached to buildings	AP20r.13.1 Projecting signs are permitted if they comply with AP20r.13.1.i (permitted conditions).	AP20r.13.2 not applicable	AP20r.13.3 Activities that contravene a permitted condition are discretionary.

AP20r.13.1.i permitted conditions

- a) there is only one sign per occupancy on the road frontage, and
- b) it does not exceed 2.5m² per sign, and
- c) it does not project more than 1.2m from the face of the building to which it is attached, and
- d) it is at right angles to the building to which it is attached, and
- e) it does not project from a verandah, and
- f) it has a clearance of at least 3m, above ground level or the footpath, measured from the bottom of the sign, and
- g) it is set back at least 600mm from the carriageway.

AP20r.13.4 assessment criteria

- a) Any potential (including cumulative) effects of additional signage on the amenity of the area.
- b) The visibility of the sign and its effectiveness.
- c) Any danger to pedestrians or motorists and other road users of signs which project over the road.
- d) The impact on the appearance of the building.

AP20r.13.5 explanation

Within these zones a higher than usual level of signage is accepted. The rule provides for this situation to continue, but in a manner which will preserve pedestrian and visual amenity.

In order to enhance the visual amenity in the area, the sign should be self-contained. That is the sign framework should be enclosed in the sign body. Refer AP20r.2.1.ii - design.

AP20r.14 signs attached to the underside of a verandah

Item	Permitted	Controlled	Discretionary
AP20r.14 Signs attached to the underside of a verandah	AP20r.14.1 Signs attached to the underside of the verandah are permitted if they comply with AP20r.14.1.i (permitted conditions)	AP20r.14.2 not applicable	AP20r.14.3 Activities that contravene a permitted condition are discretionary.

AP20r.14.1 permitted conditions

- there is only one sign per occupier or tenancy on the site, and
- it does not project beyond the outer face of the verandah, and
- there is a clearance from the bottom of the sign of at least 2.5m above ground level or the footpath, and
- it is positioned at right angles to the kerb line, and
- it is located not less than 500mm from the end of the verandah erected in respect of any site

AP20r.14.4 assessment criteria

- Any potential (including cumulative) effects of additional signage on the amenity of the area.
- The visibility of the sign and its effectiveness.
- Any hazard to road or footpath users.
- The impact on the appearance of the building.

AP20r.14.5 explanation

The rule provides for one under-verandah sign per occupier or tenancy on the site. This generally provides each tenant or lease holder an opportunity to have individual signage.

Figure 9: Explanatory Figure - Signs Attached to the Underside of a Verandah

Note: This figure is not to scale and does not illustrate all the requirements in the rules

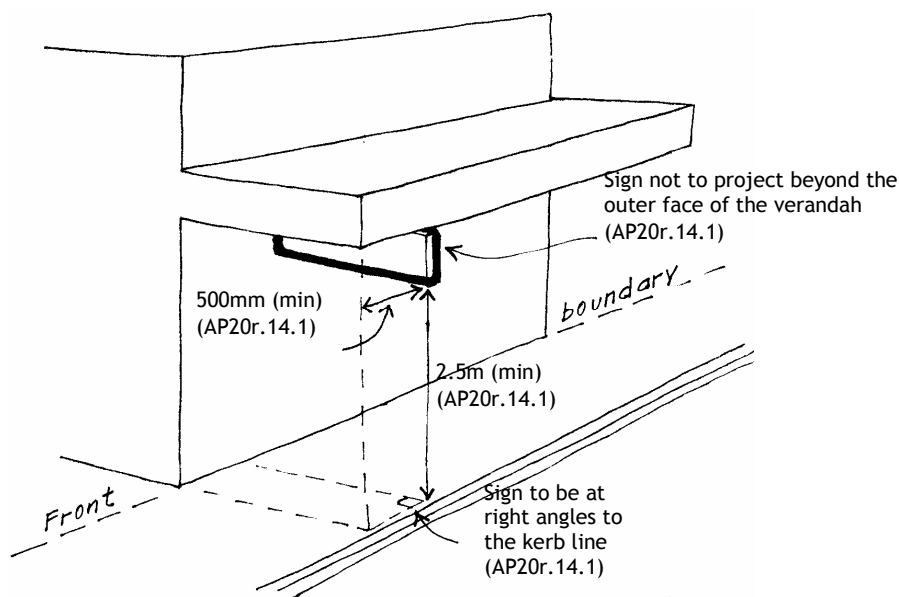

AP20r.15 signs painted on or attached parallel to buildings

Item	Permitted	Controlled	Discretionary
AP20r.15 Signs painted on or attached parallel to buildings (including verandah fascia signs)	AP20r.15.1 Signs must comply with AP20r.15.1.i (permitted conditions).	AP20r.15.2 not applicable	AP20r.15.3 Activities that contravene a permitted condition are discretionary.

AP20r.15.1 permitted conditions

- not exceed 30% of the total wall space as viewed from any public place, and
- not project more than 50mm from the wall, or fascia to which it is attached.

AP20r.15.4 assessment criteria

- Any potential (including cumulative) effects of additional signage on the amenity of the area.
- The visibility of the sign and its effectiveness.
- Any hazard to road or footpath users.
- The impact on the appearance of the building.

AP20r.15.5 explanation

Within these zones a higher than usual level of signage is accepted, but it needs to be in a manner which will preserve pedestrian and visual amenity.

Figure 10: Explanatory Figure: Projecting Signs Attached to Buildings Signs Attached to the Underside of a Verandah Signs Painted on or Attached to Buildings

Note: This figure is not to scale and does not illustrate all the requirements in the rules

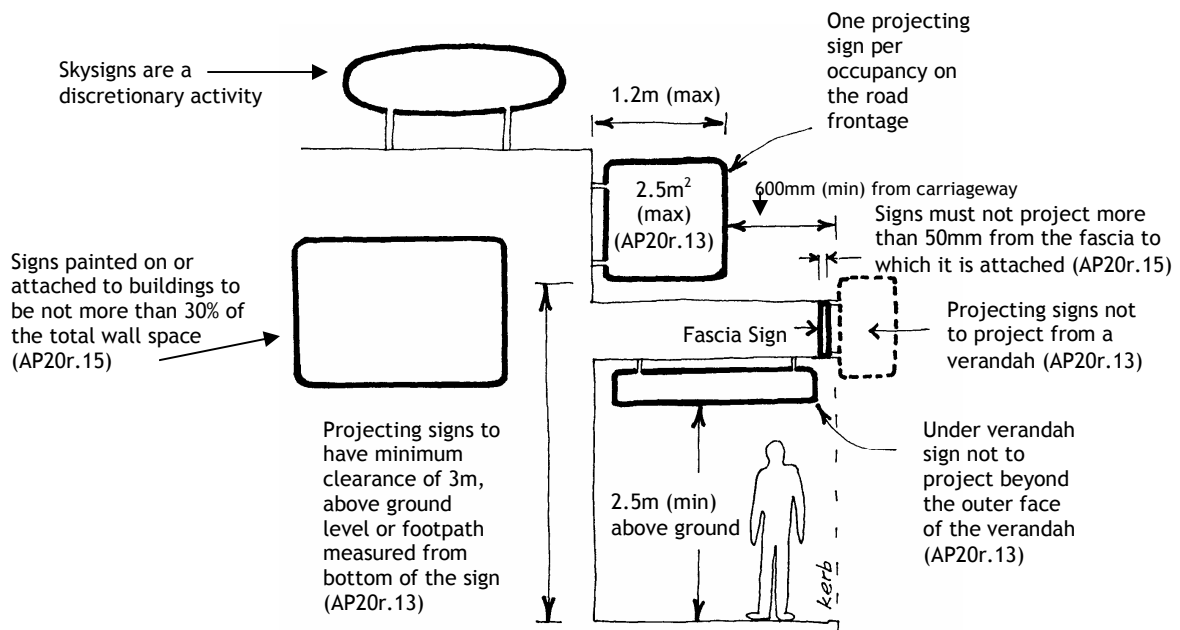

AP20r.16 rule applying to the coastal marine area and conservation zone

AP20r.16 signs in the coastal marine area and conservation zone

Item	Permitted	Controlled	Discretionary
AP20r.16 Signs in the coastal marine area and conservation zone	AP20r.16.1 Signs are a permitted activity if they comply with AP20r.16.1.i (permitted conditions).	AP20r.16.2 not applicable	AP20r.16.3 Activities that contravene a permitted activity are discretionary

AP20r.16.1 permitted conditions

- a) Signs are associated with an activity approved under a Department of Conservation: Conservation Management Strategy or Conservation Management Plan, and
- b) The signs comply with the Department of Conservation Outdoor Sign Manual: Edition number 1, September 1994 (ISBN:0-478-01512-7), and
- c) If the sign is located on or adjacent to a legal road it must:
 - i) have the prior written consent of the road controlling authority, and
 - ii) be an information sign as defined in the Department of Conservation Outdoor Sign Manual: Edition number 1, September 1994 (ISBN:0-478-01512-7), and
- d) If the sign is located within or less than 200m from any landscape overlay it must:
 - i) not exceed 1m in height, and
 - ii) not exceed 1.5m².

AP20r.16.4 assessment criteria

- a) Any potential impact of the sign on the amenity and special character of the area.
- b) Impact on views.
- c) The need for the sign in the particular location and its relationship to the location.
- d) Any possible alternative locations or methods.
- e) Whether the impacts of the activity can be remedied or mitigated sufficiently for it to be accommodated within the landscape.
- f) Matters contained in Appendix 9 (landscape components and views).

Also see general assessment criteria (AP20r.1.4.i) and general traffic assessment criteria (AP20r.1.4.ii).

AP20r.16.5 explanation

Signs in accordance with an approved Conservation Management Strategy or Conservation Management Plan are considered generally suitable in this zone. Refer also to Section 4(3) of the Resource Management Act for details of exemptions to land use consents.

Signs within or adjacent to any landscape overlay are discretionary activities to ensure that sufficient care is taken with signs in these areas of higher visual sensitivity.

Signs on or adjacent to a legal road are discretionary activities to ensure that any adverse effects on the safety and efficiency of the road network are addressed.

AP20r.17 – AP20r.18 rules applying to the Open Space and Recreation Zone

APr.20.17 free standing directional signs

Item	Permitted	Controlled	Discretionary
AP20r.17 Free standing traffic directional signs	AP20r.17.1 Signs must: a) not exceed 1m in height, and b) not exceed more than 0.5m ² , and c) be limited to directional arrows and “entry” or “exit” or equivalent terminology, and d) be placed completely within the site.	AP20r.17.2 not applicable	AP20r.17.3 Activities that contravene a permitted condition are discretionary.

AP20r.17.4 assessment criteria

- Traffic safety benefits of having larger, taller or additional signage.
- Amenity effects on the surrounding area.
- Other signage on site, and cumulative effects.

AP20r.17.5 explanation

The need for signage to direct vehicles to car parks or in a particular direction is accepted. These signs should generally be no larger than they need to be, and care needs to be taken with the surrounding environment to ensure that too much or confusing advertising does not eventuate.

APr.20.18 advertising signs

Item	Permitted	Controlled	Discretionary
AP20r.18 Advertising signs	AP20r.18.1 Advertising signs are permitted if: there is only one sign per road frontage advertising the facilities or coming events, and it does not exceed 2m in height, and it does not exceed 1.5m ² .	AP20r.18.2 not applicable	AP20r.18.3 Activities that contravene a permitted condition are discretionary.

AP20r.18.4 assessment criteria

- Traffic safety benefits of having larger, taller or additional signage.
- Amenity effects on the surrounding area.
- Other signage on site, and cumulative effects.
- The rules relating to signs in the adjoining zone.

AP20r.18.5 explanation

The need for some signage on public reserves, particularly if they are sporting venues, is accepted. Such signs must be related to the facilities available or to specific activities, and not general advertising or billboards which may detract from the open space appearance of the area.