

appendix 15

daylight admission (residential)

AP15 overview

AP15.i Daylight controls have been included in this Plan to ensure adequate minimum daylight standards for neighbouring residential properties.

AP15.1 introduction

AP15.1.i The controls are to ensure equitable access to daylight on all properties, and to ensure that minimum building separation, open space and amenity are maintained within residential areas. The daylight controls define angles within which a complying building must fit in order to allow adequate daylight onto adjoining sites.

AP15.1.ii The provisions in this Appendix apply to buildings as defined in Chapter 2.

AP15.2 where they apply

AP15.2.i The daylight controls apply to all properties within or adjoining the Residential Zone. This means that all residential properties must comply, as well as properties zoned Inner City, Suburban Commercial, Industrial, Rural, Open Space and Recreation which adjoin a site in the Residential Zone.

For those properties which are in other zones which adjoin a Residential Zone, the relevant rules still apply. However, where the Daylight Around method is implemented on a site adjoining a Residential Zone, a maximum or average building height of 7.5m applies (see AP15.9). The intent of this rule is that the daylight admission on the common boundary is the same as if the non-residentially zoned neighbouring site was within a Residential Zone.

AP15.3 where to take measurements from

AP15.3.1 in the residential zone



- a) Boundaries, other than road boundaries, including nominated boundaries in the case of multiple residential units where no subdivision is occurring. Note: Party (common) walls are exempt from the daylight provisions, as are boundaries other than road boundaries that adjoin any other zone (with the exception of the Open Space and Recreation Zone). In other words, a residentially zoned site does not have to provide daylight amenity to an adjoining industrial site, for example.
- b) Road boundaries where a building is located within 4m of the road boundary, in which case a recession plane inclined into the residential site of 45⁰ applies in all instances only to that part of the building that intrudes into the 4m setback (except in the Wakefield Quay Precinct where Rule AP23.4.2 applies). The recession plane is measured from 2.5m vertically above the road boundary. Where a road widening designation is shown on the Planning Maps and defined in Appendix 24 (designations) this is considered the road boundary. The daylight over method must be utilised in relation to road boundaries. The daylight around method does not apply. This rule ensures the public amenity of the street environment is protected.
- c) Where a boundary has a common boundary with a private access or right of way which serves more than one, but no more than four, actual or potential residential units, and whether or not that property has rights over the access or right-of-way, the measurement may be taken from the centre line of that formation. If the measurement is taken from the centre line the daylight-over method must be used.

AP15.3.2 in other zones

- a) The zone boundary. Where a road runs along the boundary between two zones, the zone boundary is the centre of the road. (See AP15.2, which requires that any site adjoining a Residential Zone complies with the daylight controls. "Adjoining" includes across the road from a residential site, since the centreline of the road is the zone boundary.)

NB: That in respect of the 5 metre strip which forms part of the Railway Reserve and is contained in part Lot 34 DP349352 and Lot 34 DP362586, measurements shall be taken from the eastern boundary of the said strip (Refer to Rule INr.27.1 c)).

AP15.4 what to show on building plans

- a) An accurate true north point.
- b) The applicable daylight over or around angle applying to the structure.
- c) Accurate original ground levels at the boundary and at the building, and finished floor levels at the points being tested (refer to Chapter 2 Meanings of Words for definition of Ground Level).
- d) Accurate original (natural) ground levels at the boundary and at the building.

AP15.5 additions to buildings



- a) Additions to buildings must comply with the daylight controls in this Plan.
- b) Where the original building does not conform with the daylight controls in this Plan, any addition must not deprive neighbouring properties of daylight to a greater degree. Otherwise a resource consent is required.

AP15.6 types of controls



AP15.6.i There are two types of daylight controls to choose from. Both are related to actual sun angles in Nelson at midday in midwinter, and are designed to ensure that daylight and/or sunlight will reach all properties at the coldest time of year.

AP15.6.ii Daylight over

Allows daylight over the top of low buildings. It requires taller buildings to be well set back from the boundary, as the maximum allowable height of a building decreases as it nears the boundary.

AP15.6.iii Daylight around

Enables daylight to be received around the sides of taller buildings. This allows for taller, narrower buildings, and is useful on steeply sloping sites.

AP15.6.iv You may choose the control that is most advantageous to you depending on the type of development you are planning. You may apply either method to a site boundary. Both methods may be used on a site, but only one may be applied to any one boundary.

(Note: the arms of the daylight around angle must not pass over any other site)

AP15.7 how to use daylight over



- a) At any site boundary a building is allowed to be a maximum of 2.5 m high.
- b) Within the site the building is allowed to reach 2.5 m plus the additional height indicated by the relevant angle on the elevation indicator in Figure 1 measured at any point along the boundary (eg. 2.5 m plus 35° measured from the boundary).
- c) To find this angle, orient the building plan towards North, and place the elevation indicator on the plan so that it is touching the inside of the site boundary concerned.

AP15.7.i Make sure the central control arrow is pointing due North as shown in Figure 2. The angle where the indicator touches the boundary is the angle to be applied 2.5 m above ground level at the boundary. This is illustrated in Figure 3.

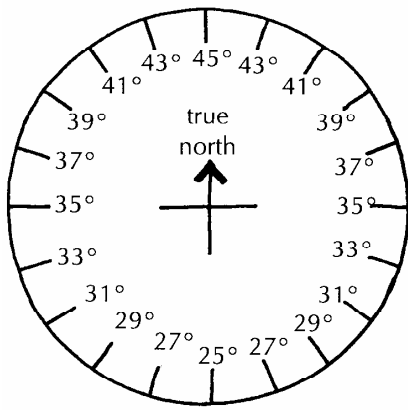

figure 1

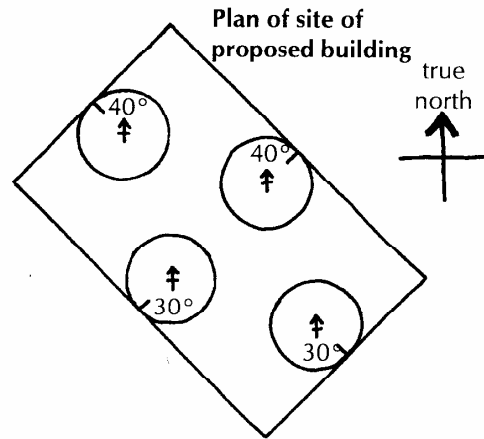

figure 2

AP15.8 calculating allowable height



AP15.8.i To calculate the allowable building height from the angle on the elevation indicator, use the following formula:

Allowable height =

$\text{Tan of the angle (refer to Table 15.8.1) } \times \text{ distance from the boundary } + 2.5\text{m}$

E.g. Allowable height 2.2m from boundary, with 35° angle
 $= (0.7002 \times 2.2\text{m}) + 2.5\text{m}$
 $= 4.04\text{m}$

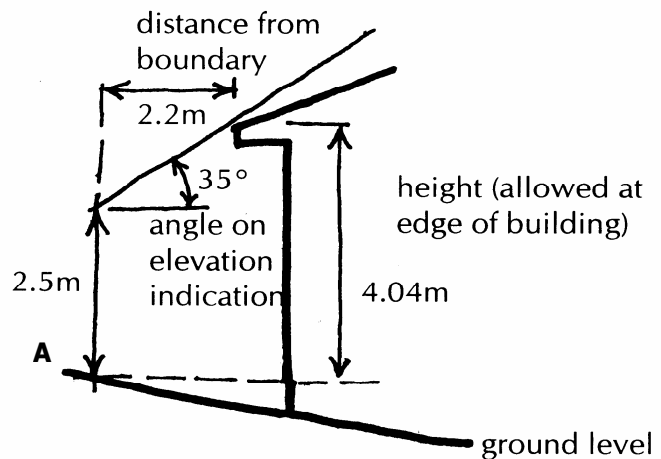

Figure 3. Calculating allowable height

AP15.8.ii This equation only works for flat sites. For sloping sites the difference between the ground level at point A and ground level at the point being measured must be added or subtracted, as shown in Figure 3.

table 15.8.1 tan of the angle

Deg	25	26	27	28	29	30	31	32	33	34	35	36	37	38	39	40	41	42	43	44	45
Tan	.466 3	.488 7	.509 5	.531 7	.554 3	.577 4	.600 9	.624 9	.649 4	.674 5	.700 2	.726 5	.753 6	.781 3	.809 8	.839 1	.869 3	.900 4	.932 5	.965 7	1.0

AP15.8.iii Exceptions to the daylight over provisions

As well as those items mentioned in the definition of buildings in Chapter 2 (such as fences less than 2m high, scaffolding, masts and poles), the following are permitted intrusions into the daylight angle:

- a) Dormer windows provided they are not more than 1.5m higher than the height permitted by the elevation indicator, and make up not more than 25% of the length of the building (measured parallel to the boundary) or a maximum length of 2.5m, whichever is the lesser.

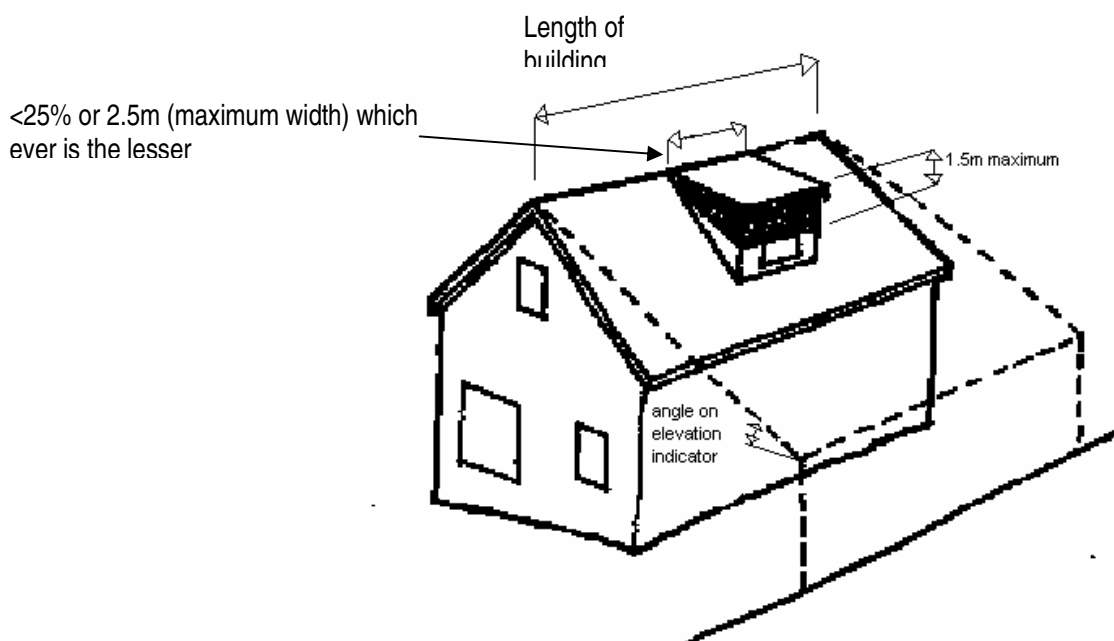

- b) Gable and other roof ends where the roof ridge is generally at right angles to the site boundary. The end of the ridge may be up to 1.5m above the indicator height, and the end area when viewed in elevation is allowed to be up to 2.5m² in area and up to 2.5m in width. Up to one intrusion is permitted per boundary. The rule provides for gable roof ends, and other alternative roof forms as shown on the diagrams attached (see Chapter 2 (Meaning of Words) for definition of 'gable').

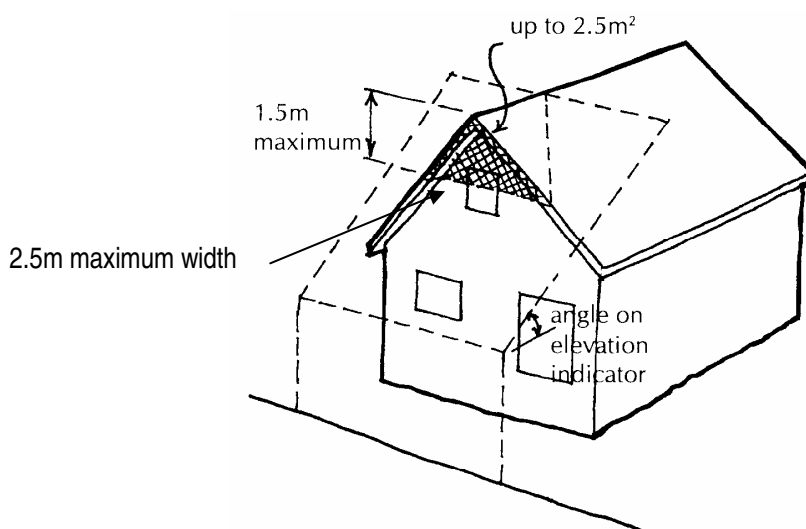

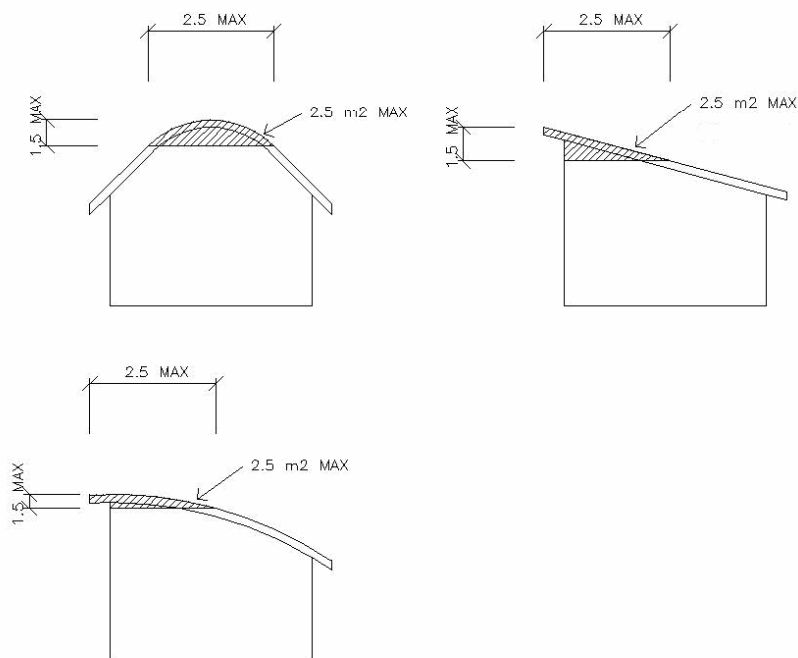
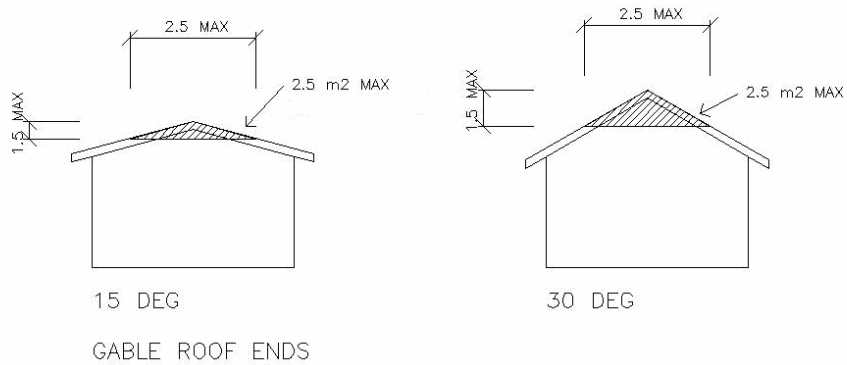

For all diagrams - Permitted Intrusions:

- Maximum 1.5m high; and
- Maximum width of 2.5m; and
- Maximum area of 2.5m²

c) Aerials except dish antennas greater than 1m in diameter (refer to aerials rules in each zone).

AP15.9 how to use daylight around

PC23

AP15.9.i Place a 110° angle 35° from the boundary (as shown in Figure 4). A complying building will fit within the arms of this angle and may be up to or average 7.5m high (see Chapter 2 Meanings of Words for definition of height measurement). Only one angle may be used on any one boundary.

AP15.9.ii 'Ground level', 'height' and 'height measurement' are determined by their definitions in Chapter 2 (Meanings of Words).

Note: Any portion of a building not contained within the arms of the angle must comply with AP15.9.iii.

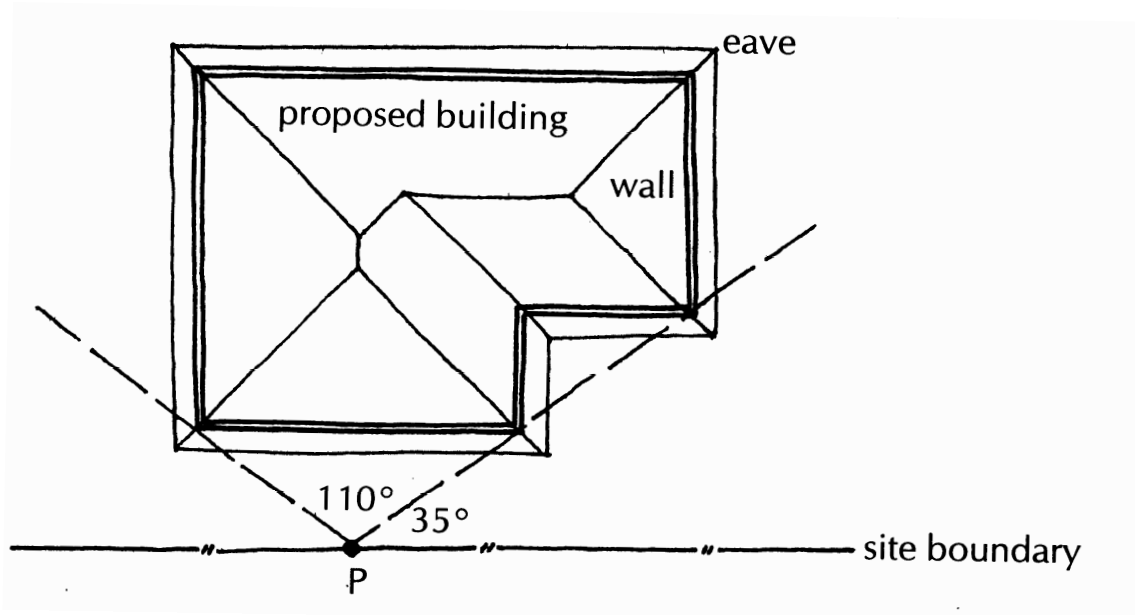

Figure 4: how to use daylight around

AP15.9.iii exceptions to the daylight around provisions

The following are permitted intrusions into the daylight around angle:

- Eaves (not more than 600mm), and
- Buildings and structures complying with the special height limiting lines outside the angle.

Parts of the building or detached outbuildings may be outside the angle but only up to a certain height. To find out how high a building outside the arms may be, use the following steps:

- Apply the daylight around angle (Figure 5) to find out how high intrusions may be. Start at 2m above ground level at the boundary immediately adjacent to the point of consideration of the building. The maximum height then increases 0.5m for each 2m distance from the boundary. This is a recession plane of 14° inclined into the site, measured from a point 2m above ground level at all points along the relevant boundary.
- The right hand side of the indicator is at 1:200 scale, and 1:100 on the left hand side. Apply the one that is appropriate to your site plan.

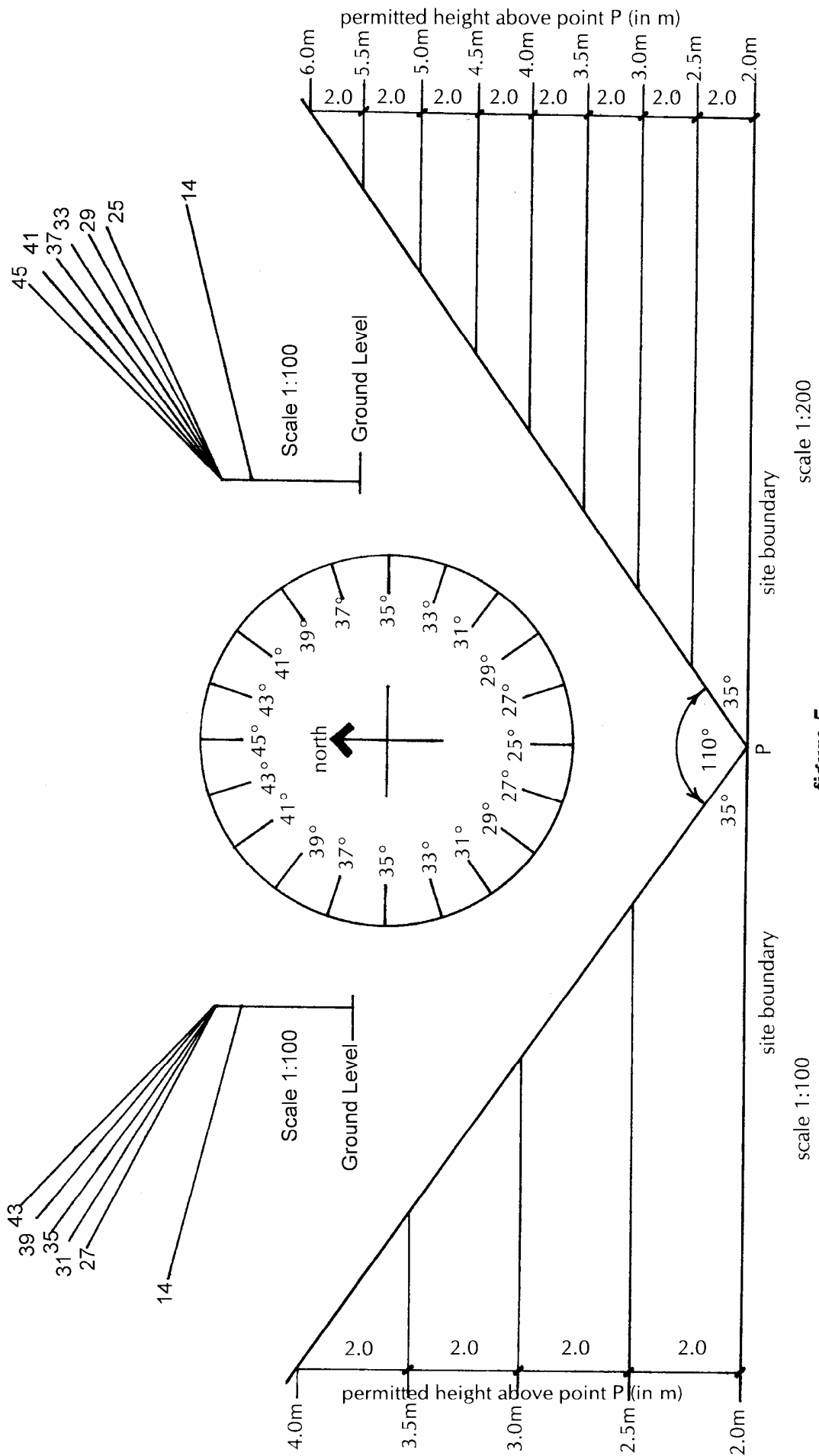

figure 5